



# TW PRO-MP, TW PRO-MP X, TW PRO-MP XL, TW PRO-HD, TW PRO-HD XL Firewood Processors

## OPERATOR'S MANUAL

Instructions for Assembly, Testing, Operation, Servicing, and Storage



**TIMBERWOLF**  
FIREWOOD PROCESSING EQUIPMENT

**⚠ STOP!**

**Read and understand this owner's manual completely before using your log splitter.**

All operators of this equipment must read and completely understand all safety information, operating instructions, maintenance and storage instructions. Failure to properly operate and maintain your log splitter could result in serious injury to the operator and bystanders or damage your splitter

[www.timberwolfequip.com](http://www.timberwolfequip.com)



Rugged frame for maximum durability

All processors are capable of splitting a minimum of 2.5 cords per hour and as many as 4 full cords per hour

State-of-the-art hydraulics make these processors the most efficient on the market at this price point



## FEATURES



### Power

- Choose 4" or 5" bore
- 3-Stage Gear Pump
- 70 gallon Hydraulic Tank

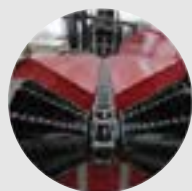

### Clamping System

- Patented Top Roll Clamping System applies up to 1000 lbs of force down on the log to ensure stability
- Large toothed Back Roller enhances traction so longer logs are fed forward

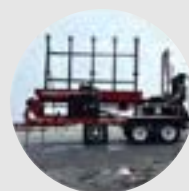

### Live Deck

- Full 8' in length allows up to one full cord to be stored and handled
- Roller chain allows deck to move heaviest logs with ease
- Stores vertically for easy transport



### Integrated Conveyor

- 12' long with a 10'10" maximum loading height
- 20" wide paddle belt
- Fully reversible for simple set up and attachment

## SPECIFICATIONS

	Base Model	Pro-HD	Pro-HD XL
Engine Power (HP)		56	74
Pump Flow (GPM)		22-22-18	33-18-14
Stroke (in.)		26	26
Trough Length (ft)		16	16
Max Log Length (ft)		32	32
Cycle Time (sec)		5.9/9.1	3/4.5
Average Output (Cord/Hr)		2.5	4
Dimensions (H"xW"xL")		129"x195"x409"	129"x195"x409"
Weight (lbs)		9,200	9,200

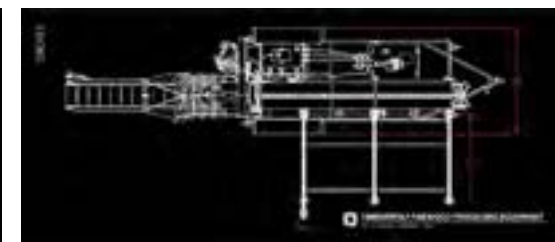

All Pro-HD Series Processors come standard with a 4-Way Wedge and 3 Strand Live Deck. 5 Strand Live Deck and Integrated Conveyor are available as Add-On Options.

▲ Full-frame commercial processor at a third of the average market price

▲ Weighing in at 5,500 pounds, the processor can easily be towed by a half-ton truck

▲ Standard with Timberwolf's patented top roll clamping system and an hourglass-shaped back roller, allowing the processor to process logs as long as 32' and wide as 2' in diameter



## FEATURES

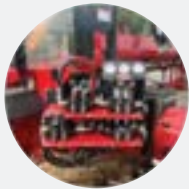

### Power

- Choose 4" or 5" bore
- 25 HP Engine
- Hydraulic pump flow of 28 GPM
- Capable of outputting 1.5 cords per hour

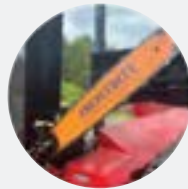

### Hydraulics

- 30-gallon hydraulic tank
- Continental hoses and fittings
- Standard 12' by 6' live deck powered by hydraulic lift cylinder

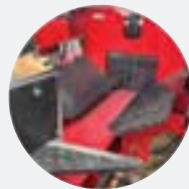

### Wedge Options

- 4-Way and 6-Way wedge options
- Hydraulic wedge lift allows easy access to the splitting chamber for re-splits



### Clamping System

- Top Roll Clamping System applied up to 1000 lbs of force to the log to ensure stability
- Large toothed Back Roller enhances traction so longer logs are fed forward

## SPECIFICATIONS & DIMENSIONS

	Base Model	Pro-MP	Pro-MP X	Pro-MP XL
Engine Power (HP)		22	25	38
Pump Flow (GPM)		22-2.6	22-18-2.6	22-18-2.6
Stroke (in.)		26	26	26
Cylinder Bore (in.)		4 or 5	4 or 5	4 or 5
Trough Length (ft)		16	16	16
Max Log Length (ft)		32	32	32
Cycle Time (sec)		5/7	5/7	5/7
Average Output (Cord/Hr)		2	2.5	3
Dimensions (H"xW"xL")		121"x110"x313"	121"x110"x313"	121"x110"x313"
Weight (lbs)		5,500	5,500	5,500

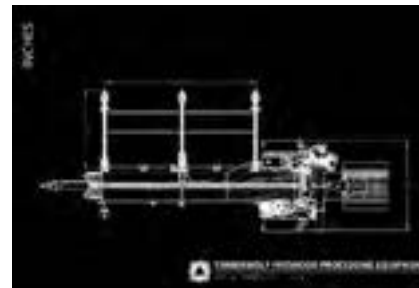



# TW PRO-MP, TW PRO-MP X, TW PRO-MP XL, TW PRO-HD, TW PRO-HD XL Firewood Processor Operation Manual

Fill out and submit registration form to ensure warranty coverage and receive product updates.

**Register online at [www.timberwolfequip.com/warranty.html](http://www.timberwolfequip.com/warranty.html)**

This manual and all its contents Copyright © 2024

Timberwolf Firewood Processing Equipment

**Record your firewood processor ID numbers here:**

Model # \_\_\_\_\_

Serial # \_\_\_\_\_

Engine # \_\_\_\_\_

VIN # \_\_\_\_\_

# Timberwolf Firewood Processing Equipment

2235 Clarks Corners Road  
Marathon, NY 13803

Toll Free: 800-340-4386

E-mail: [info@timberwolfcorp.com](mailto:info@timberwolfcorp.com)  
[www.timberwolfequip.com](http://www.timberwolfequip.com)

**©Timberwolf is a trademark of Timberwolf Firewood Processing Equipment. All other brands or product names are trademarks or registered trademarks of their respective holders.**

©Timberwolf Firewood Processing Equipment 2024. Printed in the USA

No part of this work covered by copyright may be reproduced in any form. Reproduction, adaptation, or translation without prior written permission is prohibited, except as allowed under the copyright laws.

Timberwolf Firewood Processing Equipment provides this document “as-is” without warranty of any kind, either expressed or implied. This includes, but is not limited to, implied warranties or conditions of merchantability or fitness for a particular purpose. Timberwolf Firewood Processing Equipment shall not be liable for any errors or omissions that may occur in this document, nor for incidental or consequential damages of any kind resulting from the furnishing, performance, or use of this document.

The information in this document reflects current or planned product features, functions, and characteristics as of the publication date. Because of on-going product improvements and feature additions, information in this document is subject to change without notice.

Revised June 10, 2024

Every effort has been made to ensure the accuracy of this document.

## About This Manual

Thank you for buying a Timberwolf firewood processor. This machine is made with high quality components and will provide years of service under normal working conditions.

Please study this manual before operating the unit as it contains important information relating to safety, operation and maintenance. Timberwolf Firewood Processing Equipment strongly suggests you keep it safely stored.

If you have questions regarding anything outlined in this manual, please call Timberwolf at **1-800-340-4386**.

## Read Entire Manual Before Operating the Firewood Processor

### Safety Note



Please take time to read this manual and learning how to operate and maintain your firewood processor safely. If you have any questions regarding assembly, use, safety, or maintenance, please call Timberwolf at 1-800-340-4386. This **firewood processor** is a powerful piece of equipment that can generate more than 25 tons of force. **Incorrect use of the firewood processor can cause serious injury or death.**

## Caution! Residual Hydraulic Energy!



*Residual energy must be released from the pressurized hydraulic fluid before any maintenance or repair work is done on the firewood processor. Hydraulic fluid can remain highly pressurized even while the processor's motor is off. Escaping pressurized hydraulic fluid can penetrate skin and cause serious injury.*

**To release residual hydraulic energy:**

1. Shut off engine
2. Move control valve back and forth, from one limit of travel to the other, at least four times
3. Hold valve for three seconds at each limit of travel



## Table Of Contents

### Safety

General Safety Instructions.....	1-8
Decal Locations .....	9-10

### Features

General .....	11-12
Components and Locations .....	13
Hydraulics .....	14
Three Chamber Pumps.....	14
Controls.....	15
Live Deck Features.....	15
Three Strand Live Deck .....	16
Five Strand Live Deck .....	16
Top Roll Clamping System.....	17
Hydraulic Chain Saw.....	18
Splitter.....	18-19
Chip Separator.....	19
Auto-Cycle Valve.....	20
Electric Auto Cycle .....	20-21
Operator Seat .....	21
Hydraulic Oil Cooler .....	22
Conveyor Kits.....	22

### Set Up Procedures

Overview .....	23
Work Area Layout .....	24
New Location Set Up.....	24-25
Live Deck Deployment Via Hydraulic Lift .....	26

### Set Up Procedures (Continued)

Processor Powered Conveyor .....	27
PRO-HD, PRO-HD XL Changing Wedges.....	28
PRO-MP, PRO-MP X, PRO-MP XL Changing Wedges .....	28
Operator Seat .....	29

### Operating Instructions

Startup Procedure.....	30
Engine Startup.....	31-32
Hydraulic Startup .....	32
Chain Saw Set up .....	32-33
Chain Saw Speed.....	33
Length Gauge Adjustment.....	33
Processing Firewood .....	34-35
General Guidelines.....	34
Processing Crooked Logs .....	34-35
Operator Station.....	36
Operations.....	36-37
Top Roll System .....	38
Cutting.....	39-40
Splitting .....	41
Auto-Cycle Operation.....	41-42
Manual Operation .....	43
Electric Auto-Cycle Operation .....	44

(continued on next page)

## Table Of Contents (Continued)

### Take Down Procedures

Shutting Petcocks .....	45
Processor Shut Down .....	45
Live Deck Retraction Via Hydraulic Lift .....	46
Towing Procedures .....	47-48

### Maintenance

General .....	49
Daily Maintenance .....	49-50
Hydraulic Fluid .....	50
Emergency Shut Off Switch .....	51
Saw Arbor Bearing .....	51
Push Block .....	52
Clamp.....	52
Live Deck .....	53
Feed Trough Chain .....	53-54
Auto-Cycle Detente Valve Adjustment .....	54-56
Troubleshooting .....	55-56

### Specifications..... 57

### Assembly & Repair

PRO-HD, HD XL .....	58-113
PRO-MP, MP X, MP XL .....	114-171

### Hydraulic Schematics.....172-178

### Limited Warranty.....179-180

### Maintenance Log.....181-182

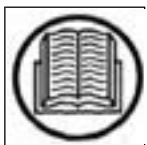

**Read this entire manual before starting or operating this firewood processor! Failure to do so could result in serious injury or death!**



### **Attention Rental Companies**

It is extremely important that you familiarize operators with the following safety instructions and that you keep a manual with the machine at all times. Require all users to read the manual before operation and be aware of all warnings and hazards.



### **High Pressure Warning!**

**Escaping hydraulic fluid can penetrate skin and cause serious injury!**

### **Caution! Residual High Pressure Hydraulic Energy**

Your firewood processor has been tested at the factory and is delivered to you ready to run. That means that there may be residual pressure in the hydraulic system. If for some reason you need to perform any maintenance or repair to the machine, you **must** release that pressure before any work can begin. Please refer to page 7 for instructions.



## General Use:

This machine was designed to process firewood only. Timberwolf strongly recommends that this machine not be modified and/or used for any application other than that for which it was designed. If you have any questions relative to a particular application, do not use the machine until you have first contacted Timberwolf or an authorized Timberwolf dealer to determine if modifications can or should be performed on the product.



- Only qualified personnel, 18 years and older, may operate the firewood processor and ONLY after reading this manual. Operators who are improperly trained or unfamiliar with this firewood processor risk serious injury to themselves and the equipment



- Before operating this firewood processor, the user must become familiar with proper emergency shut down procedures
- Do not stand on any part of the machine while it is running, for any reason; pinching or crushing injury is possible
- Never operate the firewood processor while under the influence of alcohol or drugs
- Never touch parts of the engine as burns can result
- Never operate the machine indoors or without adequate ventilation. Ensure that plenty of fresh air is available. Failure to do so could result in carbon monoxide poisoning



- You should always wear eye protection, hearing protection, snug fitting work gloves (loose gloves and clothing increase risk of snagging) and steel toed boots when you operate or work near this machine





## Drawing In/Trapping Hazard

Drawing in/trapping points exist where objects are pulled into equipment, e.g., when a log drops onto the log cradle from the log lift. Machines are stronger and faster than people; always stop the equipment before attempting to remove an item that is stuck. Remember, guards cannot be provided for all situations and equipment must be able to function in the capacity for which it was designed.



## Impact Hazard

Impact hazards can be broken down into two categories: forceful collision and contact. The first type of impact hazard, forceful collision, is the result of machinery or processes where any movement of tools, machine elements or particles could impact an operator. The second type of impact hazard, contact, refers to the movement of personnel that could result in collision with stationary or moving objects. For example, an operator could collide with a part of the firewood processor while handling wood in preparation to processing. Guarding may not be feasible for these types of hazards. **Be aware of your surroundings, never place yourself in a situation where you are in the path of a moving piece of equipment.**



## Burn Hazard

The potential for burns exist in and around the engine. Be careful not to touch any of these surfaces, which are covered in the manufacturer's safety warnings. Read the engine manufacturer's warnings and follow their instructions carefully.



## Fire Hazard - Flammable

- Since this machine uses a diesel powered engine, there is a risk of fire. Read and follow all safety precautions outlined by the engine manufacturer or fire and serious injury may result
- Store fuel and oils in an approved flammable liquid storage container
- Dispose of waste liquids, spill-cleaning material and oil-soaked rags in an appropriate covered fireproof container(s) located at least 25 feet from the firewood processor
- Only use dry powder, foam, or CO2 type fire extinguishers on or near the firewood processor
- Never use water to extinguish any diesel or oil fire



## Moving the Firewood Processor

- Only use suitable rated transport devices to move your firewood processor
- The firewood processor is heavy and requires the proper equipment to lift or move. Observe proper procedures for lifting and/or moving the firewood processor
- Wear steel-toed boots when moving or operating the firewood processor



## Residual Risk

Residual Risk is defined as the portion of risk that remains after all safety measures have been taken. Although we have taken extensive measures to protect the operator and/or maintenance personnel from injury, all hazards cannot be removed. This manual provides graphical illustrations to aid in identifying potentially hazardous areas associated with your Timberwolf firewood processor.



## Crushing Hazard

Crush points are created when two moving objects move towards each other or when one object moves towards a stationary object. For example, the push block moving towards the splitting wedge.

To prevent being crushed or pinned, learn to recognize and avoid potentially dangerous situations.



## Shear Hazard

Shear points are hazardous because of their cutting force and they often move so rapidly that they may not be visible, so it is easy to forget they are there. For example, shear points are created when the edges of two moving objects move close or across one another with enough speed or force to cut a soft material. Because some shear points cannot be guarded, it is important to be aware of their potential hazard and stay alert during operation.



## Entanglement Hazard

Rotating shafts are the most common source of entanglement accidents, although any exposed machine part that rotates can be a potential entanglement hazard. A cuff, sleeve, pant leg, long hair, or just a thread can catch a rotating shaft and result in serious injury or death. Entanglement with a wrap point can pull you into the machine, or clothing may become so tightly wrapped that you are crushed or suffocated. In other cases, you could be thrown off balance and fall into other machine parts. Even a perfectly round shaft can be hazardous if there is enough pressure to hold clothing against the shaft. Hazards increase with shafts that are not round. Ends of the shafts that protrude beyond bearings are also dangerous. Check all equipment for potential entanglement points and be alert to their potential danger.

## General Warnings for Safe Processor Operation

Always do the following:

- Read this manual before using the firewood processor
- Locate the firewood processor only on firm level ground
- Site must provide solid footing for operator (not slippery underfoot)
- Site must be free of tripping hazards (stumps, roots, stones, debris, etc.)
- Always wear the hardhat with face shield and hearing protection supplied by Timberwolf Firewood Processing Equipment, as well as hand and foot protection
- Keep away from the processing area and push block while operating
- Stand **ONLY** in the operator area when operating the firewood processor

### Log Handling



- ALWAYS grasp logs in the middle and NOT by the ends
- NEVER put anything into a partially split log as it may close suddenly and eject or pinch the item
- NEVER put anything between the log and cradle
- NEVER climb over or straddle the firewood processor





## General Cautions

- NEVER process anything other than wood logs
- DO NOT move or reposition the firewood processor when the engine is running
- DO NOT alter or modify the firewood processor in any way
- DO NOT operate the firewood processor with another person - one person operation only
- Only one person must position the logs and operate the controls
- Keep all bystanders at least 30 feet away from the firewood processor
- NEVER operate the firewood processor if you are under the influence of drugs, alcohol or medication or when you are tired
- DO NOT allow an untrained person to operate the firewood processor
- DO NOT allow anyone under the age of 18 to operate the firewood processor
- DO NOT leave the machine unattended with the engine running

## What You SHOULD Do

- Inspect hydraulic hoses every day – check for worn, frayed, kinked, and cracked areas
- Replace any damaged or worn hoses
- Use sheet of cardboard or piece of wood to check for hydraulic leaks while system is running
- Depressurize system to release residual hydraulic energy before starting any repairs
  1. Shut off engine
  2. Move control valve handle back and forth, from one limit of travel to the other, at least four times
  3. Hold valve for three seconds at each limit of travel
- Contact Timberwolf or an authorized Timberwolf dealer to replace worn components

## What You SHOULD NOT Do

- Never process anything other than logs
- Don't handle logs by their ends when you position them
- Never place your hands at pinch points where they can get caught between a log and the wedge, push block, or log cradle
- Don't put any part of yourself, your clothing, or your personal protective equipment into a crack in a log that's being processed. It might close suddenly and with great force
- Don't put anything between the log cradle and the side of a log. Logs spread as they're forced against the wedge
- Do not straddle or climb over the firewood processor at any time
- Do not move or reposition the firewood processor with the engine running
- Do not modify or alter the machine in any way, at any time
- Never team up with another person to operate the firewood processor – it's a one-person job
- Never operate firewood processor under the influence of alcohol, drugs, or medication
- Never allow an untrained operator to use the firewood processor
- Never allow anyone under age eighteen to operate the firewood processor
- Never remove cap from hydraulic tank while engine is running or while tank is still warm after engine is shut off. Hot pressurized oil can cause serious injury, so wait for hydraulic tank to cool, then release residual energy before removing cap (see page 7)
- Never use any connectors, valves, or fittings that are different from the ones originally installed on the firewood processor



## Decal Locations (TW PRO-HD, TW PRO-HD XL)

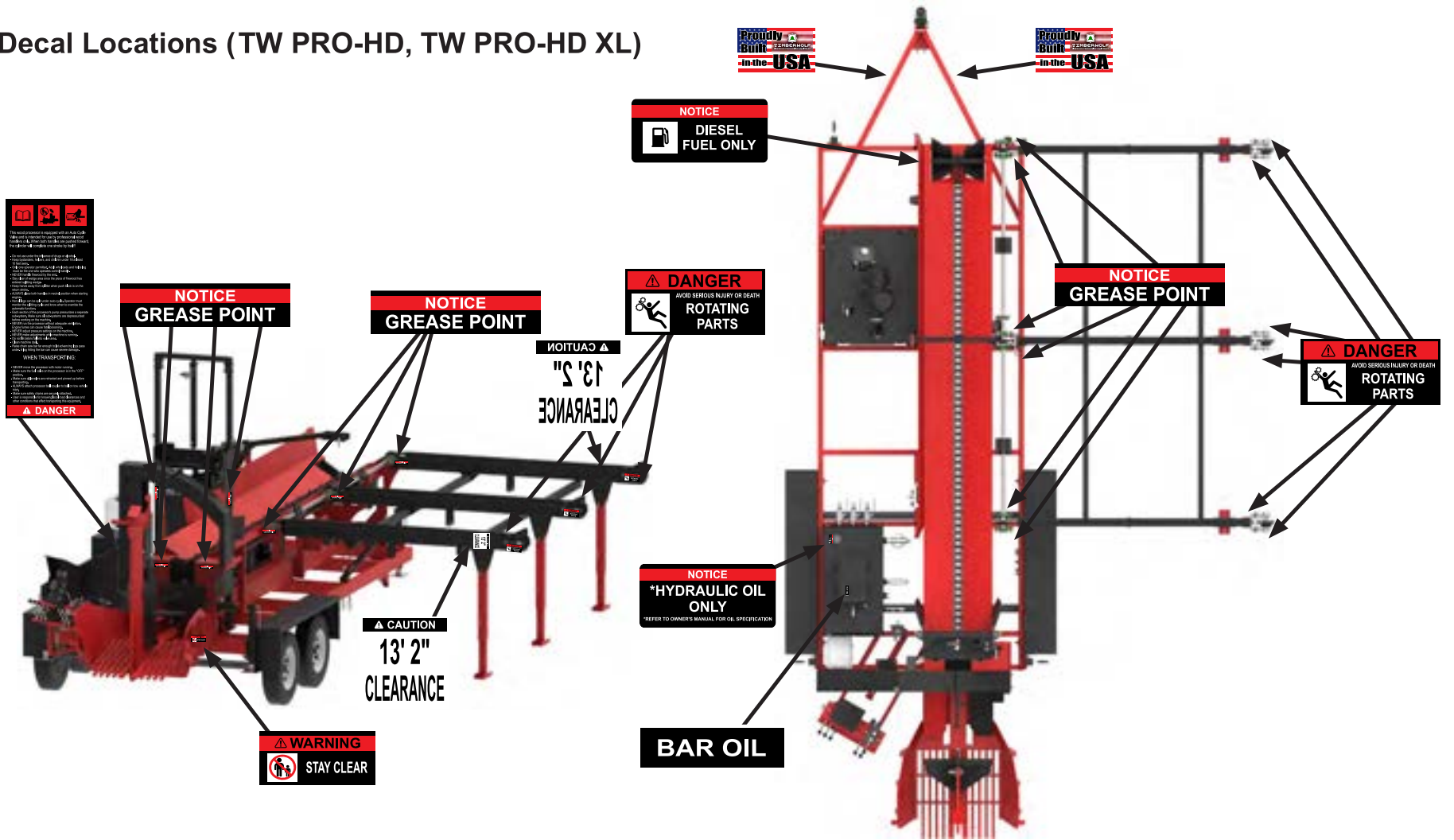

**NOTE:** Piston, valve and engine manufacturers apply their own warning labels. Please refer to the components' separate instructions and safety information before operating the firewood processor. Failure to do so may result in serious injury or death.

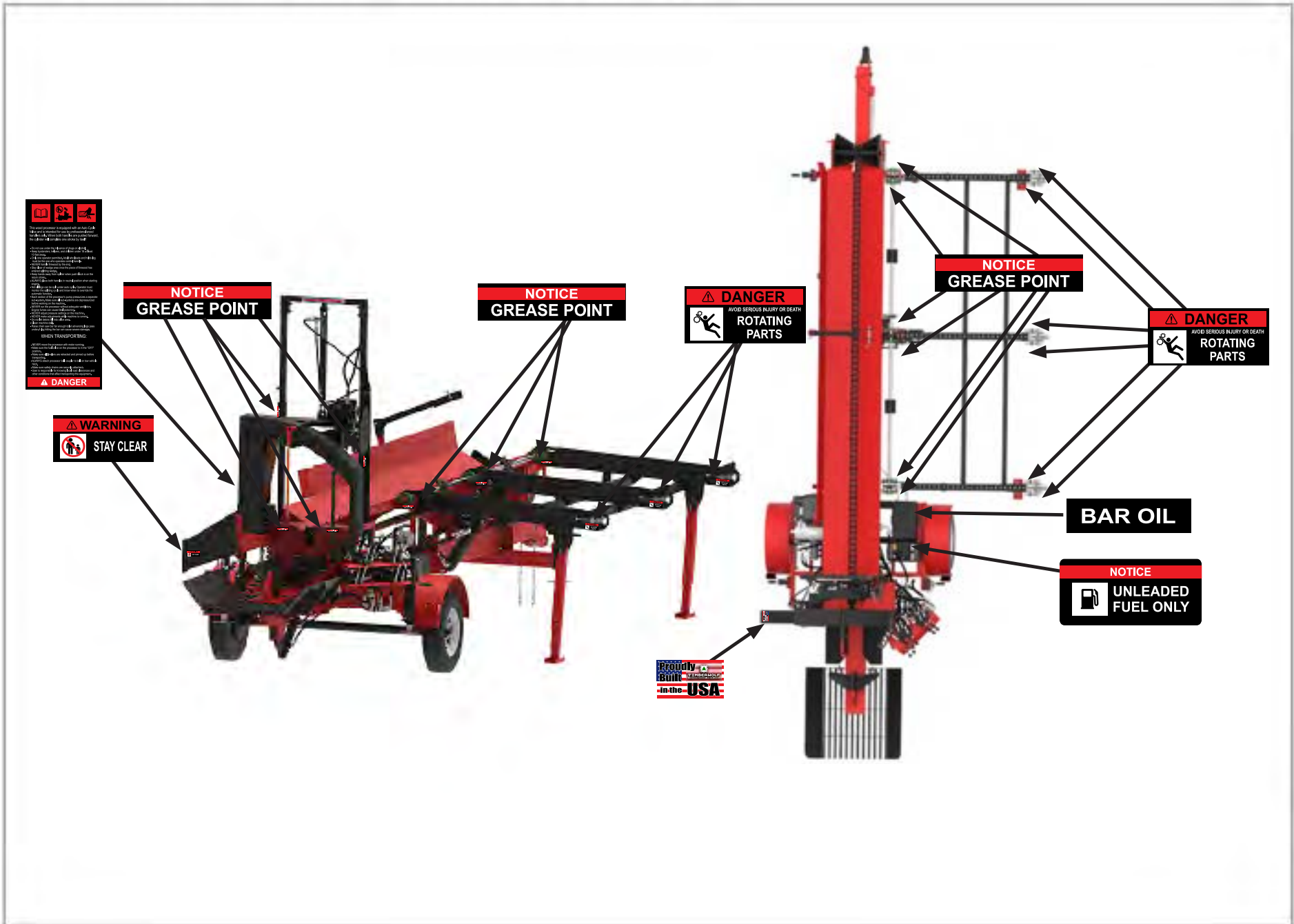

**⚠ DANGER**

The operator is exposed to the following hazards when using this equipment:

- **Rotating Parts:** The rotating parts of this equipment can cause serious injury or death. Always use proper safety techniques when operating this equipment.
- **Pinch Points:** The moving parts of this equipment can pinch or crush fingers, hands, or feet. Always use proper safety techniques when operating this equipment.
- **Blade:** The blade of this equipment can cut or crush fingers, hands, or feet. Always use proper safety techniques when operating this equipment.
- **Fire:** The engine of this equipment can start a fire. Always use proper safety techniques when operating this equipment.
- **Electrical:** The electrical system of this equipment can cause an electrical shock. Always use proper safety techniques when operating this equipment.
- **Exhaust:** The exhaust of this equipment can cause carbon monoxide poisoning. Always use proper safety techniques when operating this equipment.
- **Lifting:** The operator can lift or move heavy loads. Always use proper safety techniques when operating this equipment.
- **Transporting:** The operator can be injured when transporting this equipment. Always use proper safety techniques when transporting this equipment.

**WHEN TRANSPORTING:**

- **Secure the Load:** The load must be properly secured to the equipment. Always use proper safety techniques when transporting this equipment.
- **Use Proper Lifting Techniques:** The operator must use proper lifting techniques when moving heavy loads. Always use proper safety techniques when operating this equipment.
- **Use Proper Driving Techniques:** The operator must use proper driving techniques when operating this equipment. Always use proper safety techniques when operating this equipment.

**NOTICE**  
GREASE POINT

**NOTICE**  
GREASE POINT

**⚠ DANGER**  
AVOID SERIOUS INJURY OR DEATH  
ROTATING PARTS

**NOTICE**  
GREASE POINT

**⚠ DANGER**  
AVOID SERIOUS INJURY OR DEATH  
ROTATING PARTS

**⚠ WARNING**  
STAY CLEAR

**BAR OIL**

**NOTICE**  
UNLEADED FUEL ONLY

**Proudly Built in the USA**



## Features

### General - TW PRO-MP, TW PRO-MP X, TW PRO-MP XL Processors

This manual covers Timberwolf Firewood Processing Equipment's TW PRO-MP, TW PRO-MP X, TW PRO-MP XL, TW PRO-HD and TW PRO-HD XL Firewood Processors. These are extremely portable, ready to use systems available with a variety of self-powered features and options.

Working from the safety of the Operator's Station, you can saw and split as much as one-half to one and one-half cords an hour with the PRO-MP Processor.

All processor functions, including the chain saw, are hydraulically driven.



TW PRO-MP  
Firewood  
Processor

*Engine specifications subject to change without notice*

## General - TW PRO-MX, TW PRO HD, TW PRO-HD XL Processors

PRO-HD/ HD XL processors feature a three section pump as standard equipment, meaning that they come fully capable of powering a firewood conveyor with a few optional conveyor valving components.



TW PRO-HD XL Firewood  
Processor

*Engine specifications subject to change without notice*

## Components and Locations

Firewood processor functions divide into –

- Transport – live deck deposits logs into the feed trough, hydraulic driven chain advances log to be cut
- Top Roll Clamp/Chain Saw Bar – hydraulic clamping mechanism holds log in position, hydraulic mechanism raises and lowers hydraulic driven chain saw
- Splitter – cut piece drops onto log carriage, hydraulic driven push block forces log against adjustable, multi-wing wedge, splits multiple pieces with one stroke
- Removal – standard drop-through chip separating grate, optional provision for powering and controlling conveyor (conveyor valving available for TW PRO-MP XL/PRO-HD/PRO-HD XL) only

Firewood Processor Function Diagram  
(Heavy Arrows Indicate Log Travel Direction)

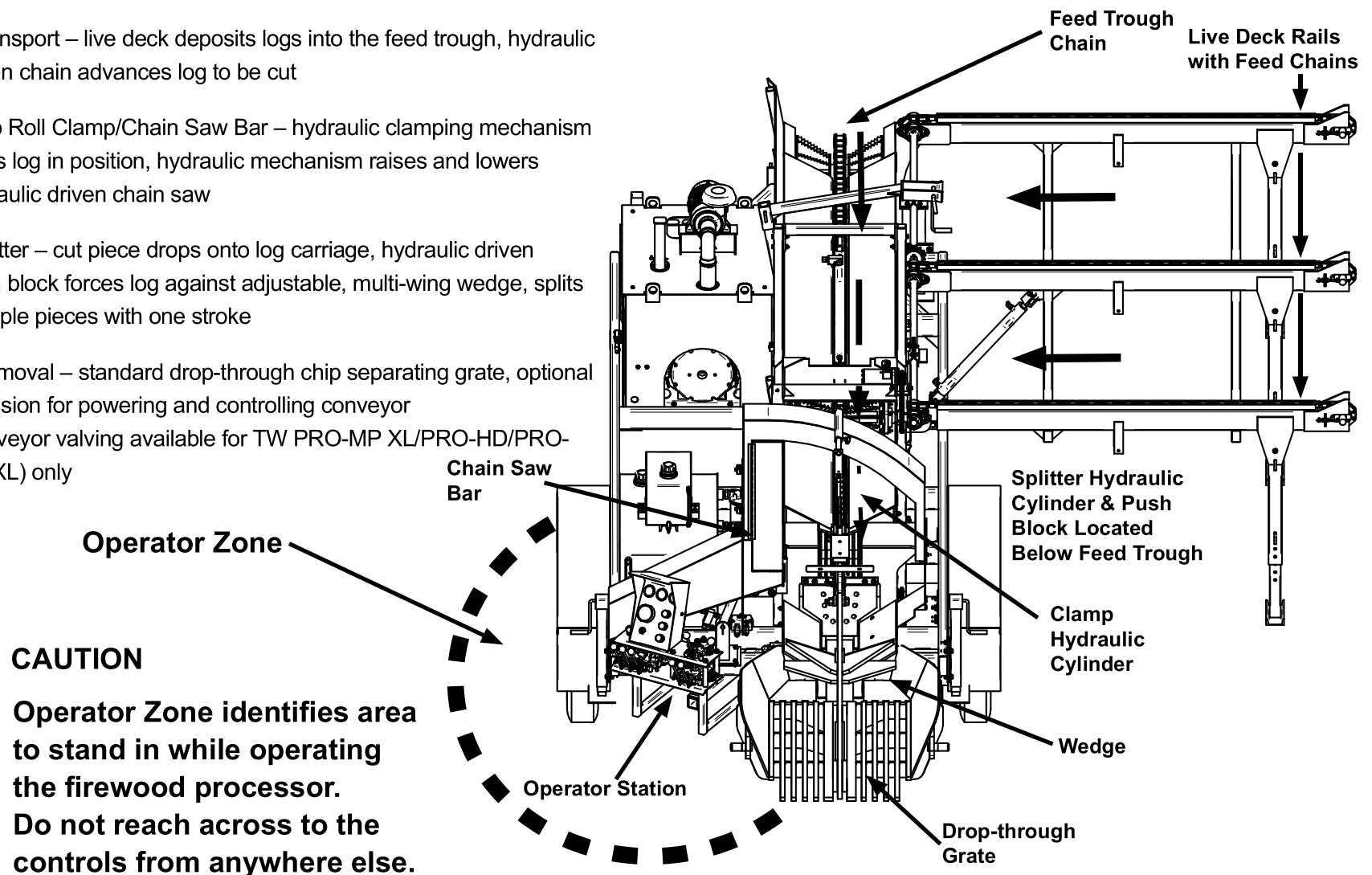

### CAUTION

**Operator Zone identifies area to stand in while operating the firewood processor. Do not reach across to the controls from anywhere else.**

## Hydraulics

The processor's hydraulic systems are complex and sophisticated. Major repairs or modifications should be handled only by Timberwolf-designated and authorized service personnel. Call your dealer or Timberwolf at 1-800-340-4386.

The Maintenance section of this manual has adjustment instructions for the splitter valve detentes. Inspect hydraulic hoses every day for loose fittings and signs of wear.

Timberwolf Firewood Processing Equipment recommends using ISO 46 hydraulic oil in its Firewood Processors.

## Three Chamber Pumps

PRO-HD/ HD XL processors feature a three-section pump as standard equipment, meaning that they come fully capable of powering a firewood conveyor with a few optional conveyor valving components.

The PRO-HD wood processors feature a 33/20/13 sectional hydraulic pump.

## Controls

Control valves are carefully positioned for safety and ease of use. The live deck, feed trough, chainsaw, wedge, and splitter are all controlled from the Operator Station. The Operator Station is located on the opposite side from the live deck.

Optional factory-installed conveyor kits add a lever below the standard array to control the conveyor belt. The kit for connecting the conveyor lift as well as the belt drive also adds a control lever for the conveyor height adjustment. Conveyor kits available for the PRO-MP XL, PRO-HD and PRO-HD XL models only.

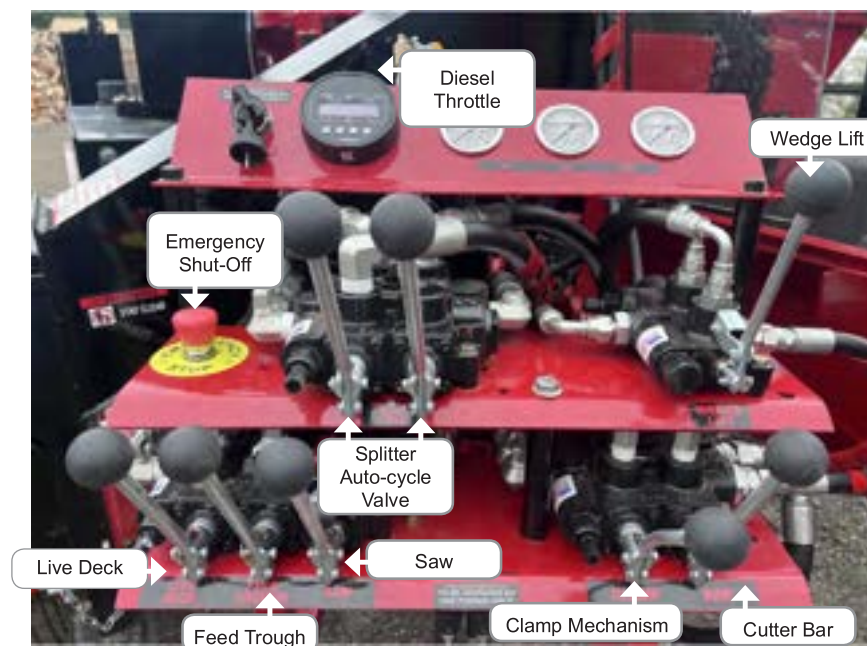

Standard Control Array

## Live Deck Features

- Single lever forward/reverse control at operator station

Height of fully raised standard live deck is 13 ft. 2 in. – low enough to travel safely on most public roads.



### CAUTION

**The user is responsible for knowing local road clearances and other conditions that affect transporting the processor.**

## Three Strand or Five Strand Live Deck

When setting up the processor, pay special attention to orienting the live deck. Arrange convenient access for your loading equipment.

All of our firewood processors are equipped with a three strand or five strand live deck. The deck rail employs a hydraulic motor to power feed chains in live deck rails mounted on the processor frame. The drive chain connects the motor to the drive axle, which has a drive sprocket for each rail. These strands are capable of holding up to one cord of logs.



### CAUTION

**The user is responsible for knowing local road clearances and other conditions that affect transporting the processor.**

The three strand live deck rails are unevenly spaced, enabling the live deck to handle a wide range of log lengths:

- Front rail to middle rail: 4 feet 8 inches on center
- Middle rail to rear rail: 6 feet 3 inches on center
- Dimensions are 8 feet by 12 feet on all 30 foot processors. On each model, the deck is centered on the feed trough for balanced and stable loading. Retracted deck height is a standard 13 feet 2 inches on all three strand models.

Hydraulic motor for feed chains in live deck rails is mounted on processor frame. Drive chain connects motor to axle, which has a drive sprocket for each rail.



Three Strand Live Deck Drive System



## Top Roll Clamping System

The Top Roll Clamping System, standard on all processor models, is operated by a hydraulically powered motor. This motor rotates the feed roller, which simultaneously clamps wood tightly and propels it forward toward the chain saw bar, where it is then held firmly in place while the chain saw bar is making a cut.

The feed roller can be easily raised and lowered to accommodate logs of varying thickness via hydraulically powered cylinder shafts attached at the center and sides of the top roll clamping system frame. The feed roller dictates the speed with which logs are fed through the chain saw and can feed logs in both forward and reverse.

The patented top roll clamping system speeds production and simplifies the firewood making process:

- Does not have to be raised and lowered every time log moves forward
- Motor driven feed roller rides over the contour of the log
- Feed roller maintains constant hold and helps feed trough chain advance log
- Top Roll speed advancement is controlled by the feed trough control lever

The top roll system's constant hold helps accurately position the last cut on each log.

Although our top roll clamping system is virtually identical on each processor model, due to their varied power plant capabilities the TW PRO-MP can only accommodate logs up to 18 inches in diameter. All other processor models can feed up to a 22 inch diameter through the top roll clamping system.

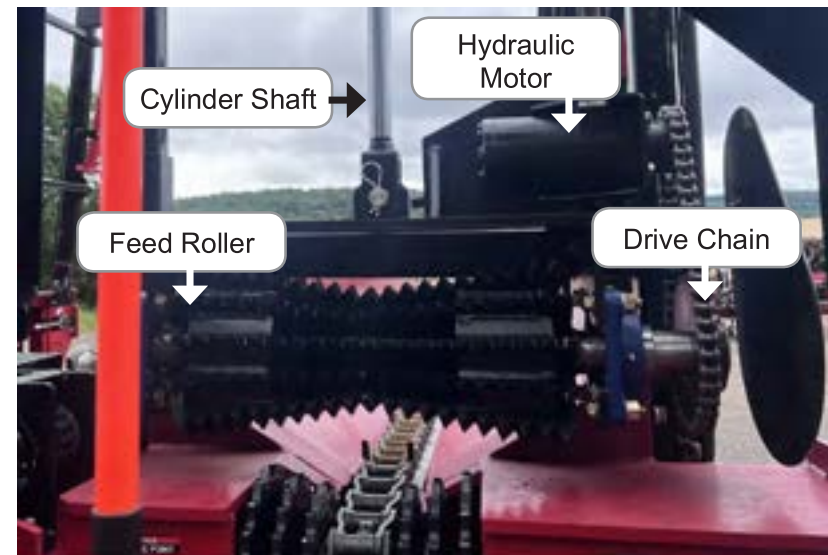

Top Roll Clamping System

## Hydraulic Chain Saw

All Processors feature a hydraulically driven and controlled chain saw that:

- Cuts logs into sections up to 24 inches long
- Features a 25-inch bar
- Uses a .404 chain
- Is equipped with an automatic chain oiler with electric pump and 5 gallon reservoir
- Is easily and safely controlled from the operator station by saw and bar levers (Please see pg 15 for saw and bar lever placement.)

The chain saw is mounted on a hydraulically controlled bar arm that is able to be raised and lowered via the control panel's bar lever. The chain itself is controlled hydraulically by a separate saw lever. The saw blade will only rotate when this lever is pulled forward. Please see pg 15 for saw and bar lever placement.

To reduce downtime, remove a dull chain and replace it with a fresh, sharp one. If you wish to sharpen a dull chain without removing it, a handheld electric sharpener gives best results. **ALWAYS TURN OFF THE ENGINE BEFORE REPLACING OR SHARPENING THE SAW CHAIN.**

**NOTE:** Chain should be sharpened at least every 9 to 10 cords. Depending on the condition of wood being cut, the chain might require more frequent sharpening.

## Splitter

When a cut is finished by the chain saw bar, wood pieces fall directly into the log carriage. From here, a hydraulically powered splitting cylinder drives a push block forward to force the wood onto the blade(s) of the splitting wedge (the initial force of the push block begins the split of the log, while the pressure of the subsequent log dropped into the carriage and pushed forward finishes the first split, depositing cleanly separated firewood pieces onto the conveyor).

(continued on next page)

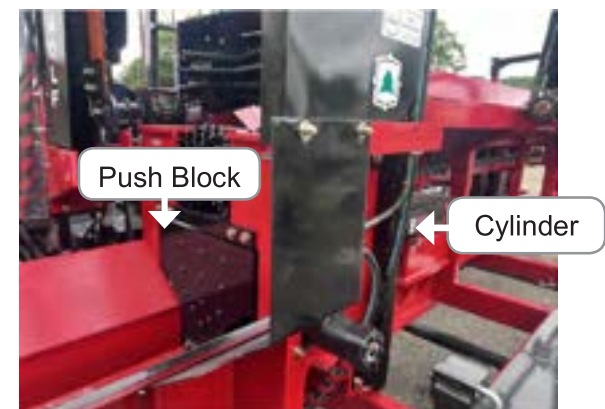

Push Block and Hydraulic Cylinder



## Splitter (Continued)

### Wedges

There are several different wedge types available: the 4-way, 6-way, 8-way and 12-way. These are named not for how many blades they are equipped with, but for how many finished firewood pieces they create. All wedges are easily adjustable and are designed so the log doesn't contact all blades at once. The staggered blades engage a log in stages for easier splitting on tough pieces. Wedge availability per model is as follows:

- **4-Way Wedge**
- **6-Way Wedge**
- **8-Way Wedge**
- **12-Way Wedge**

### Wedge Lift

The PRO-HD, and PRO-HD XL processor units feature a top-mounted hydraulic wedge lift. The PRO-MP, PRO-MP X and PRO-MP XL utilize a bottom mounted hydraulic wedge lift. These allow for adjustment of the wedge's vertical position, which enables the wedge to be centered on logs of varying diameters for maximum splitting efficiency. The wedge lift is operated from the control panel using the wedge lift lever. Please see pg 28 for placement.

### Chip Separator

The chip-separating grate lets most chips, splinters, and debris fall through the splitter hopper for a cleaner finished product. The drop-through grate keeps debris from falling onto the conveyor where it might cause belt alignment and slippage problems.

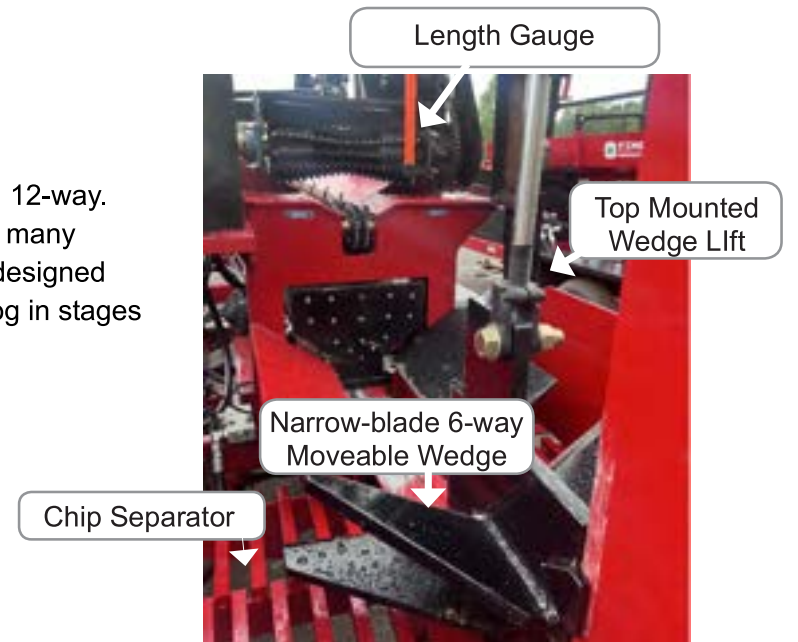

Splitter Wedge Assembly  
PRO-HD, PRO-HD XL



Splitter Wedge Assembly  
PRO-MP, PRO-MP X PRO-MP XL

## Auto-Cycle Valve

All Pro-HD series and Pro-MP series are equipped with an auto-cycle valve, which enables the splitter's push block to automatically complete a forward stroke and return to fully retracted position. This frees the operator to begin the next cut while the current log splits.

Operation of the auto-cycle valve depends on forward and return detente settings to control the cylinder and push block as they extend and retract. The detentes should be set for hands-free splitting on normal wood. See the pg 59 of this manual for auto-cycle adjustment instructions.



### CAUTION

**Auto-cycle control is intended for use by professional wood handlers only! Not all logs can be processed under auto-cycle control. Operator must monitor the splitting cycle and know when to override the automatic function.**

Wood that resists splitting – because it is hard, twisty grained, or knotty – can make the detentes kick out to neutral position. When that happens, the push block usually starts back but will occasionally stop in place. The splitter can be operated manually to split logs that kick out the detentes.

The standard auto-cycle valve is controlled by a pair of levers mounted on the control panel. Please see pg 15 for placement.

## Electric Auto-cycle

Timberwolf firewood processors can be factory-equipped with an electric auto-cycle feature. Pushbuttons control the splitter in place of the standard two-handle, manually operated auto-cycle valve.

Electric auto-cycle is standard on the PRO-HD XL.

(continued on next page)

## Electric Auto-cycle (Continued)

Timberwolf firewood processors can be factory-equipped with an electric auto-cycle feature. Pushbuttons control the splitter in place of the standard two-handle, manually operated auto-cycle valve.

Electric auto-cycle speeds processing by simplifying the control routine. In addition to its convenience, the electric valve requires less frequent adjustment than the two-handle valve.

Most instructions in this manual are written for the two-handle valve with separate instructions as needed for electric auto-cycle.

## Operator Seat

Timberwolf firewood processors can be factory-equipped with a cantilever-mounted seat for the operator station (the seat swings out of the way, or can be easily removed, when the operator prefers to stand). The seat mount is a 2 inch receiver located below the hydraulic control valves. A self-locking retainer pin secures the seat base in the receiver.

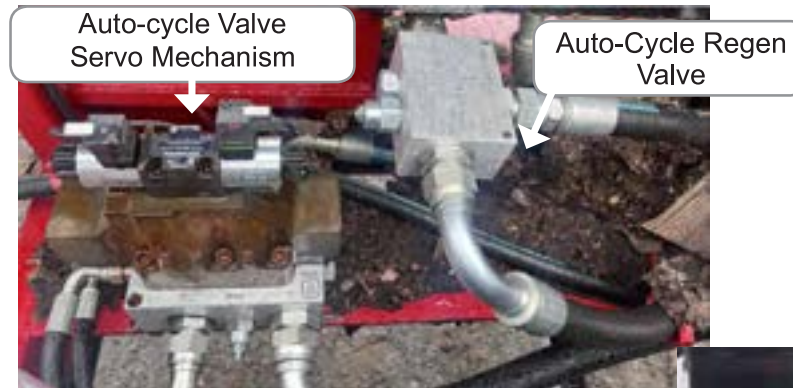

Top and Right: Electric Auto-cycle Components



Processor Controls with Operator Seat

## Hydraulic Oil Cooler

Timberwolf firewood processors can be factory-equipped with a hydraulic oil cooler to improve hot weather performance. Consult your Timberwolf dealer to determine what's best for your local temperature conditions. Hydraulic oil coolers are standard on the PRO-MP X, PRO-MP XL, PRO-HD and PRO-HD XL. Not Available on the PRO-MP.

## Conveyor Kits

Timberwolf processors that have a three part hydraulic pump (PRO-MP XL, PRO MX, PRO-HD, PRO-HD XL) can be factory-equipped to power and control a Timberwolf hydraulic conveyor.



Hydraulic Oil Cooler

# Set Up Procedures

## Overview

This part of the manual contains instructions for setting up the processor at the work site.

## Set Up Procedures

- Planning the work area
- Positioning and leveling
- Live deck deployment (Electric Winch and Hydraulic)
- Processor Powered Conveyor Hookup
- Operator seat

## Work Area Layout

- Locate processor on firm, level ground
- Select well-lit spot, outdoors or in well-ventilated area



### CAUTION

**Never run the processor without adequate ventilation. Diesel engine fumes can be fatal.**

- Check for hazards around the processor. Make sure area is free of slippery surfaces and objects you could trip over
- Make sure there won't be people or animals in the area around the processor
- Plan for –
  - Log supply – access to load logs onto the live deck
  - Split wood takeaway – Conveyor to truck or pile
  - Sawdust handling – collection and removal
  - Chip removal under the grate

## New Location Set Up

Position processor in the selected location, then disconnect tow vehicle:

1. Block wheels firmly so processor can't roll in either direction
2. Raise corner leveling jacks to lift processor ball coupler off tow vehicle's trailer hitch
3. Disconnect safety chains, emergency brake cable, and wiring harness for processor, lights and brakes
4. Drive tow vehicle clear
5. Adjust leveling jacks at the front and back until processor is level

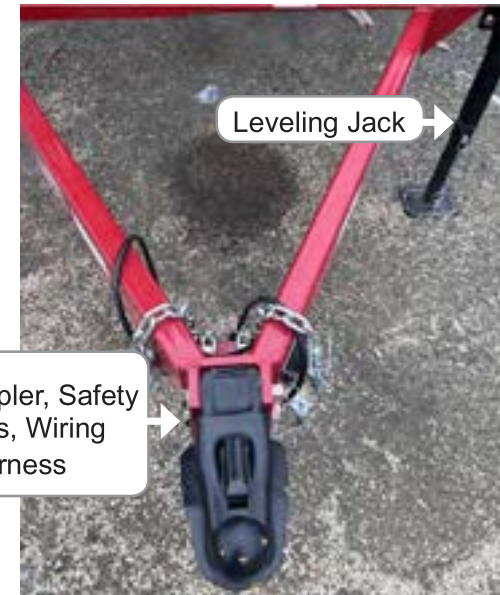

Ball Coupler, Safety Chains, Wiring Harness

Leveling Jack

Processor Towing Hitch

(continued on next page)



## New Location Set Up (Continued)



### CAUTION

Never use the hitch failure emergency brake unit as a parking brake. Using the break-away brake as a parking brake while hitched to the tow vehicle will overload the electrical system and burn out the wiring. Using it will also drain battery when un-hooked.

## Live Deck Deployment Via Hydraulic Lift

The Hydraulic Deck Lift is standard on all PRO-HD series and PRO-MP series firewood processors. Instructions for deployment using the hydraulic lift are as follows:

1. Make sure the processor's engine is running.
2. Remove the retainer pin from the transport arm/transport mast connection.
3. Push the hydraulic deck lift lever down(see right) to slowly and carefully lower the live deck until it is just above parallel with the ground. Make sure that you have enough room to unfold the deck's legs.
4. Remove the deck leg's retainer pin and unfold the leg until it is perpendicular to the deck strands. Reinsert the retainer pin through the leg's storage housing and the leg itself. Secure the retainer pin by reinserting its hairpin. Repeat as necessary for remaining legs.
5. Using the deck lift lever, continue to lower the live deck until its legs are firmly on the ground. It should be level with the feed trough.

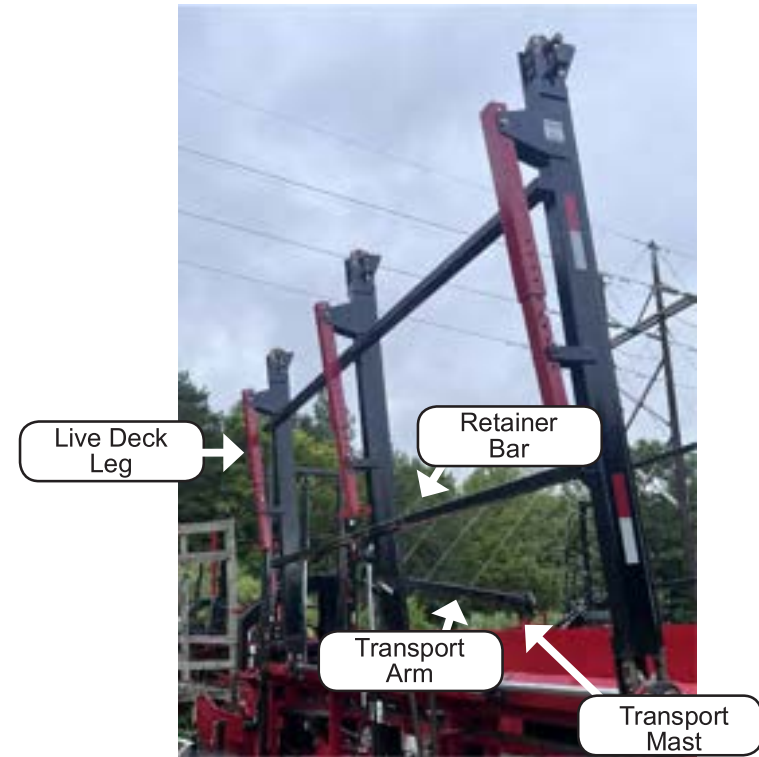

Retracted Live Deck



### WARNING

Never stand under live deck.

## Live Deck Deployment Via Hydraulic Lift

Instructions for deployment using the hydraulic lift are as follows:

1. Make sure the processor's engine is running.
2. Remove the retainer pin from the transport arm/transport mast connection.
3. Push the hydraulic deck lift lever down(see right) to slowly and carefully lower the live deck until it is just above parallel with the ground. Make sure that you have enough room to unfold the deck's legs.
4. Remove the deck leg's retainer pin and unfold the leg until it is perpendicular to the deck strands. Reinsert the retainer pin through the leg's storage housing and the leg itself. Secure the retainer pin by reinserting its hairpin. Repeat as necessary for remaining legs.
5. Using the deck lift lever, continue to lower the live deck until its legs are firmly on the ground. It should be level with the feed trough.





## Processor Powered Conveyor

Processor models PRO-MP XL , PRO-HD and PRO-HD XL can be equipped to power a Timberwolf hydraulic conveyor and control it from the operator station. Two types of factory-installed conveyor kit are available:

- Belt drive only – one set of hydraulics (control valve, hoses, connectors).
- Chain drive– includes second set of hydraulics for conveyor’s lift mechanism, control valve, hoses, connectors.

1. Position conveyor.

2. Make hydraulic connections. Connectors accept standard, barrel-style, self-locking hydraulic fittings. These are quick connect/disconnect fittings.



### CAUTION

**Always depressurize the entire processor hydraulic system before connecting or disconnecting any hydraulic fitting. Failure to observe this caution can result in serious injury.**

Consult conveyor Maintenance and Operation Manual.

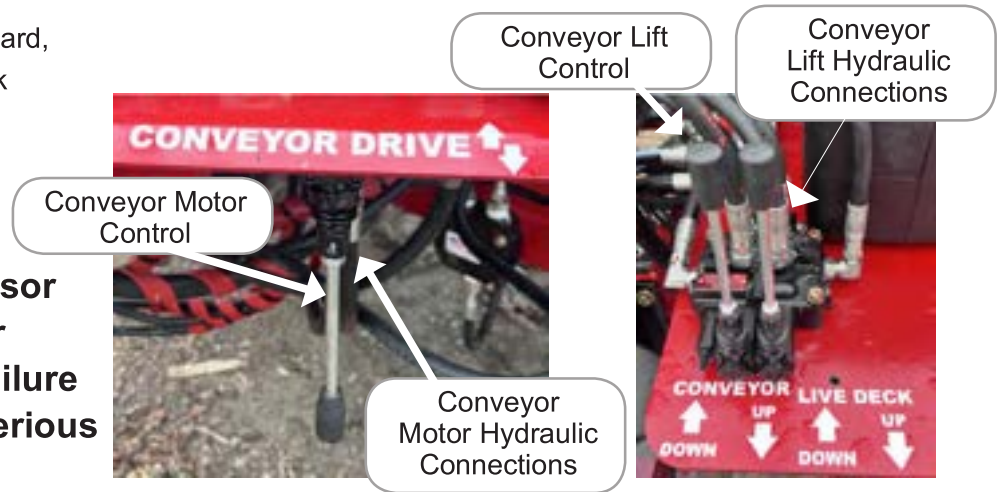

Conveyor Control Levers & Hydraulic Connections

## PRO-HD, PRO-HD XL Changing Wedges

To change the processor's moveable wedge:

1. Turn engine on.
2. Lower wedge as far as it will go.
3. Shut off engine.
4. Pull cotter pin and remove heavy pin that secures the wedge to the wedge lift bracket.
5. Swing wedge-lift cylinder out of the way and support it.
6. Lift and remove wedge. A separate piece of heavy lifting equipment such as a tractor with a bucket or forklift, skid steer with a bucket will be needed along with a chain or hoist assembly. Use the hole where the heavy pin was in for lifting.
7. Position new wedge into log carriage and swing wedge lift cylinder back into place.
8. Align wedge lift bracket, then replace securing pin and lock it in place with cotter pin.

## PRO-MP, PRO-MP X PRO-MP XL Changing Wedges

To change the processor's moveable wedge:

1. Turn engine on.
2. Raise wedge up as far as it will go.
3. Shut off engine.
4. Disconnect wedge lift cylinder from wedge lift rocker link.
5. Remove set screw from pin and pin from wedge.
6. Remove wedge and replace it with the new wedge.
7. Reinstall pin into wedge and set screw into pin
8. Reconnect wedge lift cylinder to wedge lift rocker link
9. Test for functionality

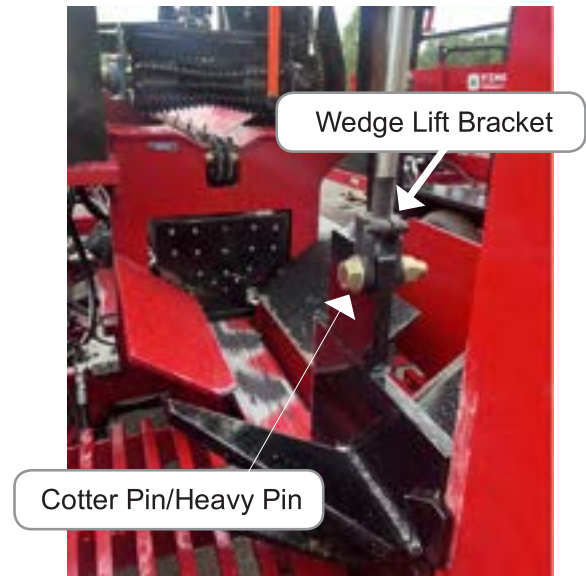

Wedge Lift Bracket  
(PRO-HD, PRO-HD XL)



Wedge Lift Bracket  
(PRO-MP, PRO-MP XL)

## Operator Seat

If the processor is equipped with the optional operator seat, it needs to be installed during set up and removed during take down. An operator seat should not be left on the machine during transport.

To install the operator seat:

1. Make sure the engine is off.
2. Remove the locking pin from the coupler sleeve located below the operator station.
3. Slide seat bracket into the coupler.
4. Replace pin.
5. Adjust seat height as needed.

Seat can be swiveled out of the way when the operator prefers to stand.

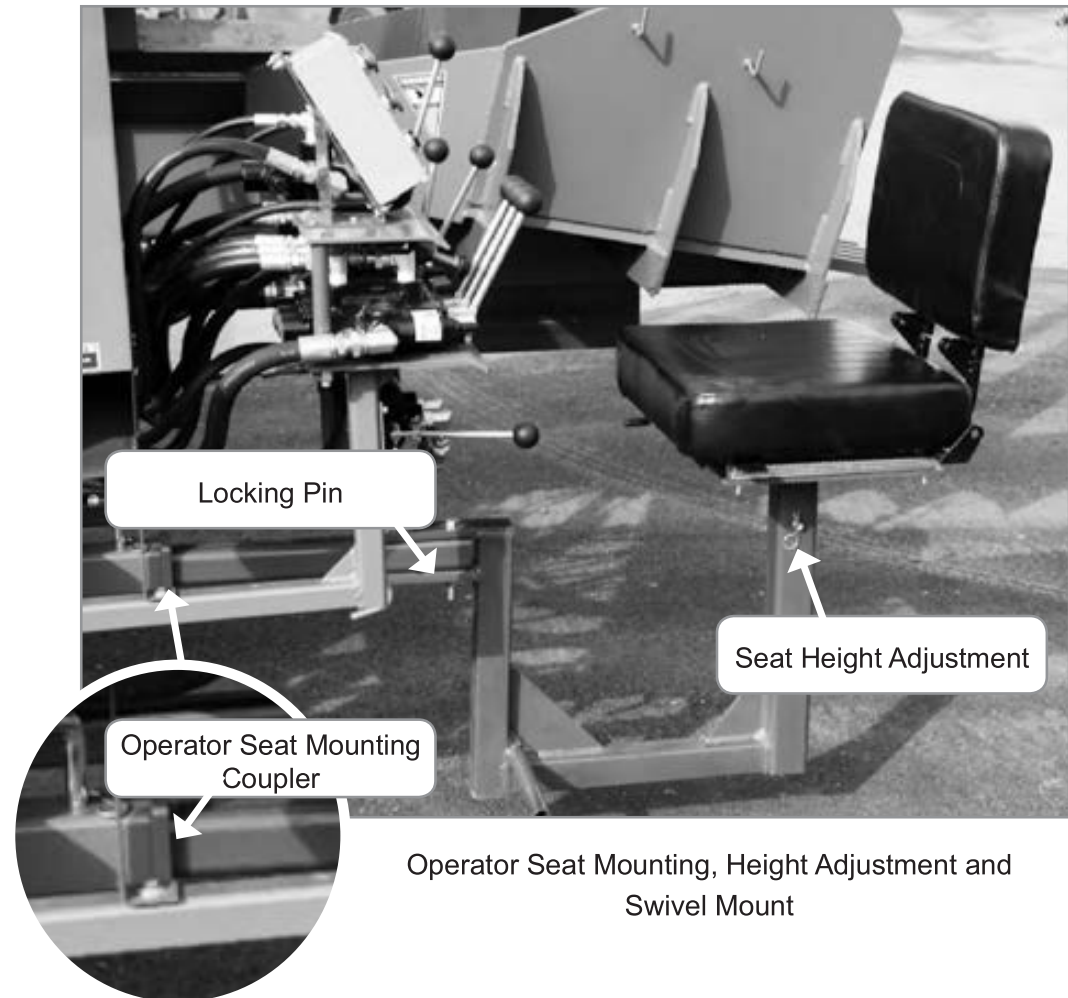

Operator Seat Mounting, Height Adjustment and Swivel Mount

# Operating Instructions

## Startup Procedure

First, walk-around the entire machine:

- Check –
  - Fluid levels:
    - Diesel fuel – start the day with a full tank –
      - Plan to use one gallon per cord of firewood;
      - Use 60/40 diesel fuel/kerosene mix in winter weather (30 ° F and below).
    - Hydraulic oil – Timberwolf Firewood Processing Equipment recommends ISO 46.
    - Chainsawbar oil – use 30 weight in summer, 10 weight in winter.
  - Petcocks on fuel, hydraulic, and bar oil lines – make sure all are open.
  - Cutting chain condition – don't start the day with a dull or damaged chain.
  - Hydraulic line condition – keep track of wear; save on downtime by replacing hoses before they fail.
  - Nuts, bolts, and fittings – make sure all are tight and secure, especially on the push block.
  - Welds – check high-stress joints.
  - Cut off length gauge chain – adjust if necessary.
  - **Wear proper protective equipment (PPE);** this includes hand and foot protection, as well as the hardhat with face shield and hearing protectors supplied by Timberwolf Firewood Processing Equipment.

## Engine Start Up

Diesel engine start up procedure:

- Make sure –
  - All control valve handles are in neutral/center position
  - No one is near any moving part
  - Emergency shut-off switch (“panic button”) is in the “ON” position (pulled up)
- Start the engine, following the instructions in its operating guide
- Allow engine to warm up at idle before you start to process firewood:
  - Always warm up for at least ten minutes
  - In winter weather (45° F and below) warm up for 60 minutes or until hydraulic oil is 80° or higher

Don't try to operate the processor before engine and hydraulic fluid are properly warmed up.

When the system is warmed up, return to the operator station and increase the engine speed.

Set a speed you're comfortable with in that range, based on your experience and judgement. Regulate engine speed by checking the tachometer located on the engine housing.

### NOTE:

New operators should run the engine at slower speeds while learning to run the processor. Operator should be familiar with the controls and comfortable running the processor before increasing engine speed.

(continued on next page)

Diesel Throttle:  
To Adjust, Use Up  
& Down Arrows



Power Plant Controls – Throttle

Emergency Shut-Off:  
Push To Shut Down Processor  
Pull Up Before Restarting



Power Plant Controls – Emergency Shut Off



### Engine Start Up (Continued)



#### CAUTION

Never let anyone within 20 feet of the processor or log pile while the processor is in operation.

### Hydraulic Start Up

Timberwolf firewood processors have an open hydraulic system that begins circulating and warming the hydraulic oil when the engine starts running.

### Chain Saw Set Up

Check the sight glass on the bar oil tank and add oil if necessary. Make sure the bar oil tank shut-off petcock is open.



Tachometer

Ignition Switch

Diesel Gauges and Switches



Bar Oil Level Sight Glass

Bar Oil Supply Shut-off

Bar Oil Tank



Bar Oil Pump Location

Bar Oil Pump Location



Bar Oil Pump Shut-off

Petcock

Bar Oil Pump

(continued on next page)

## Chainsaw Setup (Continued)

### Chain Saw Speed

The hydraulic flow controller that governs chain saw speed is located below and to the left of the hydraulic control levers. Normal running speed is the #2 position. Check the setting each day to be sure it hasn't been changed accidentally. You may adjust the speed of the saw chain and cylinder speed to best suit your material and style.

Chain saw speed shouldn't need to be adjusted very often.

### Length Gauge Adjustment

Set the processor's length gauge to guide you in sawing off uniform pieces.



Chain Saw Speed Control



Loosen Set  
Screw Adjust  
Position for  
Selected Length

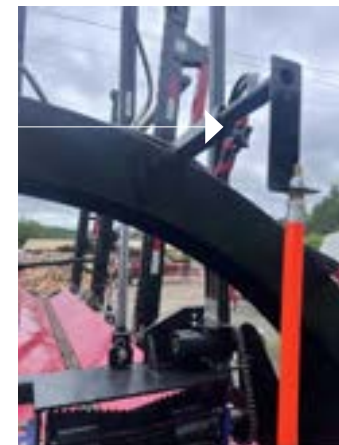

Inline Splitter  
Length Gauge Adjustment

## Processing Firewood

**PRO-MP** - Maximum log diameter is 24 inches. The PRO-MP's 16 foot feed trough can handle logs up to 32-feet long.

**PRO-MP X** - Maximum log diameter is 24 inches. The PRO-MP X's 16 foot feed trough can handle logs up to 32-feet long.

**PRO-MP XL** - Maximum log diameter is 24 inches. The PRO-MP XL's 16 foot feed trough can handle logs up to 32-feet long.

**PRO-HD** - Maximum log diameter is 24 inches. The PRO-HD's 16 foot feed trough can handle logs up to 32-feet long.

**PRO-HD XL** - Maximum log diameter is 24 inches. The PRO-HD XL's 16 foot feed trough can handle logs up to 32-feet long.

### General Guidelines

Logs should be as smooth as possible and free of knots, bumps, and branches. Always try to point the butt end toward the wedge.

Use good judgment about log lengths, size, and straightness. The processor's production rate depends chiefly on the size of the wood being processed and your ability to run the machine efficiently.

### Processing Crooked Logs

Processing crooked logs takes judgement and experience. Most crooked logs can feed through the machine without problems when handled correctly. Less experienced operators, though, should avoid them because they can make problems:

- Crooked logs can catch and damage clamp or saw mechanism.
- Crooked logs often result in pieces with ends cut diagonally, instead of square.
- Diagonal pieces cause problems and slow down operations because they tend to slide off the push block or the piece ahead, and can even pop up out of the splitter hopper.

(continued on next page)



## Processing Firewood (Continued)

### Processing Crooked Logs (Continued)



#### CAUTION

**When you split a diagonal piece, watch carefully as it begins to split. Make sure the end closest to the wedge doesn't start to come up toward you as it pushes against the piece in front of it. If the end of a piece does start to lift, retract the push block and use the supplied pickeroon to reposition the piece.**

As with anything you do processing wood, operating this machine is a learning process. As you spend more time with it you will become more proficient with it. Always pay attention. Never become complacent. Do not hesitate to call Timberwolf Firewood Processing if you have any questions about how to use the machine.



#### CAUTIONS

- Never adjust pressure settings on the machine.**
- Never make an adjustment while machine is running.**
- Do not take chances.**
- Do not let debris fall into the valve area.**
- Clean the machine of debris daily.**
- Do not operate this machine when you're tired or while taking any form of medication, drugs, or alcohol.**

### Operator Station

Splitter (Auto-cycle)		
Push for manual retract		
Pull & release to split		Pull & release for auto retract
Hyd Wedge	Feed Trough	Saw
Push to raise	Pull for forward	Release to stop
Pull to lower	Push to reverse	Pull to run
Live Deck	Clamp	Bar
Push for reverse	Push to Float	Push to raise
Pull for forward	Push to Raise	Pull to lower
	Pull to Neutral	
	Pull to Lower	

**NOTES:**

Splitter: For auto-cycle operation, pull and release both handles together. For manual splitter control, use only left splitter handle.

### Operations

Procedures for processing firewood divided into four parts:

- Transport – Live deck moves logs into feed trough and feed trough advances logs to be cut
- Clamping – Top Roll holds log in place for cutting
- Cut off – Separate controls for chain saw motor and lowering/raising chain saw bar
- Splitting – Wedge positioning and auto-cycle operation; manual operation for problem pieces

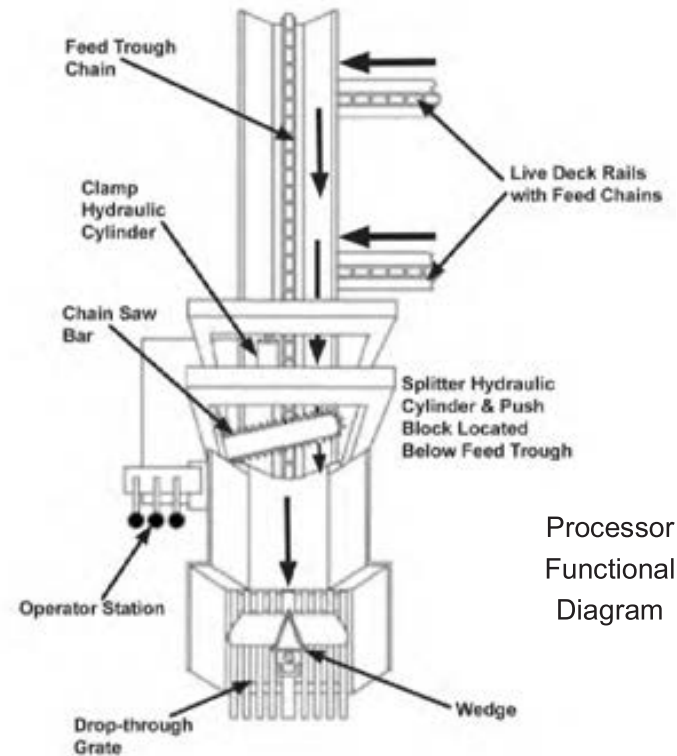

Processor Functional Diagram

(Continued on next page)

## Operations (Continued)

1. Load logs onto deck with butt ends pointed toward the cutoff bar and splitter. Make sure logs are parallel to feed trough and weight is evenly distributed on deck strands
2. Live deck lever controls drive chains in the deck strands. Pull lever to move logs toward feed trough, push back for reverse
3. Advance logs carefully. Make sure only one log is positioned to drop into the feed trough



Live Deck Lever

### NOTE:

If more than one log does fall into the feed trough, shut down the processor and remove the extra log(s) from the trough.

4. After log drops into feed trough, move it forward to be cut off by the chain saw



### CAUTION

**Advancing log without properly positioning the top roll and cutoff bar can cause severe damage to the equipment.**

5. Before you advance the log, make sure the top roll clamping mechanism is raised far enough to let the log under the roller. Make sure the chain saw cutoff bar is in the full upright position as well
6. Advance log until it touches the length gauge chain
7. If log moves too far, push on the feed trough control lever for reverse
8. Engage top roll



Feed Trough Lever



Length Gauge

## Top Roll System

To operate top roll feed mechanism:

1. Push back on the clamp control lever to raise the roller. Lift just enough to let the incoming log pass under; advancing log should make the roller turn
2. When the log is under the roller, push the clamp lever all the way forward into the float position, releasing the roller to ride over the log's contour
3. The float position of the roller is enough to hold a log while the saw makes most cuts
4. Pull the feed trough lever to advance the log until it touches the length gauge chain. If the log advances too far, back it up by pushing back on the lever
5. Saw off piece and start splitter auto-cycle once the log is completely in splitting area
6. Repeat advancing and cutting log
7. The last cut on some logs can require extra clamping pressure to prevent tipping. For manual clamping –
  - Pull the valve handle back into the neutral position
  - Carefully pull on the handle to exert as much pressure on the log as needed
  - Return to float position before advancing the log again
  - Roller cannot climb over bumps on a log while manual clamping pressure is applied and will break top roll mounting hardware if moved while under pressure
8. Pay attention while you operate the machine:
  - Check how the roller rides on the log
  - Don't let the end of a log sneak up on you
  - Set roller onto each log; don't drop it roughly

## Cutting

When the log is extended to the length gauge chain and firmly held in float position by the clamping mechanism, you're ready to cut off a piece to be split.

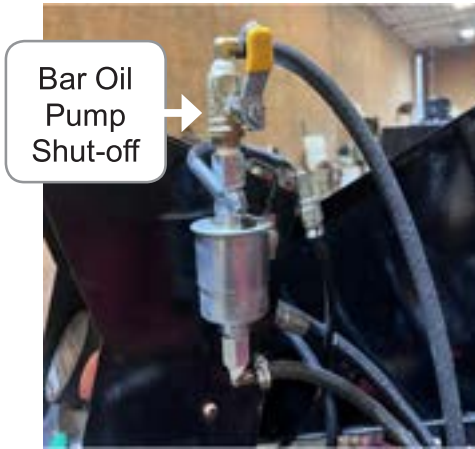

Bar Oil Pump

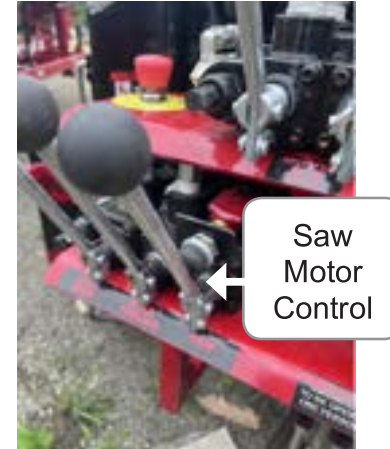

Saw Lever

### NOTE:

Make sure oiler pump valve is open about one quarter turn to regulate bar oil. In mild weather use 30-weight bar oil. Use 10-weight oil at winter temperatures (30° F and below).

(continued on next page)

## Cutting (Continued)

When log is in cutting position:

1. With your left hand, pull and hold saw lever to engage the chain saw. Saw only runs while you hold the lever in position. Running the chain also runs the bar oiler
2. At the same time, pull on the bar control lever with your right hand to bring the saw down for the cut. Push back on the lever to raise the saw
3. When the bar gets near the log, slow it down and approach carefully. Slamming the saw bar into a log can stall the chain
4. Apply more pressure as the bar enters the cut. Go slowly and carefully to feather the saw bar through the cut. As your experience increases, you'll know just how much pressure to exert with the valve handle
5. Exerting too much pressure can stall the saw motor. If that happens, let go of the bar lever to release the pressure and let go of the saw lever to stop the chain. Lift the bar up out of the cut by pushing back on the bar lever, then re-start the saw motor and begin the cut again
6. If the saw binds in a cut, reduce pressure on the bar control lever. If it continues to bind, raise the bar and bring it down again to make the cut wider
7. For a clean cut that drops the log smoothly into the splitter, hold the bar control until the log falls. Lifting the bar too soon can leave a hinge in the wood and make the log tumble into a bad position
8. Release the saw control lever when the cut is done. The lever returns to neutral position and the chain stops turning
9. At the same time, with your other hand, push back on the bar lever and raise the chain saw bar into position for the next cut



### CAUTION

**Be sure to raise chain saw bar to the full upright position to let advancing log pass by. A log hitting the bar can cause severe damage.**



## Splitting

The fourth processing operation is to split each piece as it's sawed off from the log. The processor's log splitter is similar to a standalone splitter. Pieces may have to be shifted to improve splitting position, and twisted or knotty pieces will exceed auto-cycle detentes and require manual control.

Always observe common rules of log splitter safety:



### WARNING

**Wear PPE: Steel Toed Boots, Tight Fitting Work Gloves, Supplied Hard Hat with Face Shield and Hearing Protection**

**Do not use under the influence of drugs or alcohol.**

**Never handle firewood by the ends. Use supplied pickeroon; keep hands OUT of splitting area**

**Stay clear of the wedge area once a log begins to split.**

**Keep hands away from the splitter during the return stroke.**

## Auto-Cycle Operation

Auto-cycle operating instructions for the log splitter:

1. The piece cut off by chain saw should drop into position on the splitter's log carriage. You may have to use the supplied pickeroon to reposition some pieces
2. Center the movable wedge on the log by adjusting up or down with the wedge lift control lever:
  - Push to raise wedge
  - Pull to lower wedge



Hydraulic Wedge Lift Lever

(continued on next page)



### Auto-Cycle Operation (Continued)

3. Pull both splitter levers to the detente position and release. Push block should completely extend and return automatically.
4. Hard-to-split pieces that exceed detente settings make the control levers kick out to neutral position, which makes the push block start back or stop in place.
5. Use your judgement when that happens. You can split some pieces by just starting the push block forward again; some pieces need to be repositioned or turned around using the supplied pickeroon; some need to be removed. You also have the option of controlling the splitter manually with just the left handle.
6. While a piece splits under auto cycle control, you can advance the log in the feed trough and start the next cut. Always keep an eye on the splitter while you do that, though.
7. Both handles stay in detente position until push block is fully extended.
8. At the end of the stroke, forward detente returns lever to neutral position.
9. Right lever remains in detente position and controls cylinder while it retracts the push block.
10. When cylinder is fully retracted, return detente kicks right lever to neutral position.

You can start cutting the next piece before the push block returns to the retracted position. DO NOT finish a cut until the push block has fully retracted.

#### NOTE:

If auto-cycle handles kick out early too often, the valve's forward detente needs adjustment. Consult Maintenance section of this manual for adjustment instructions.

## Manual Operation

Use left splitter lever to control the log splitter manually for tough logs that kick out the auto-cycle detentes:

1. Leave right splitter lever in neutral position
2. Pull and hold left splitter lever to extend the push block
3. When log is split, push and hold the lever until push block is fully retracted
4. Return lever to neutral position
5. Center the movable wedge on the log by adjusting up or down with the hydraulic wedge control lever:
  - Push to raise wedge
  - Pull to lower wedge



## Electric Auto Cycle Operation

Electric auto cycle (not available for the PRO-MP or PRO-MP X) operating instructions for the log splitter:

1. Piece cut off by the chain saw should drop into position on the splitter's log carriage. You may have to use the supplied pickeroon to reposition some pieces.
2. Center the movable wedge on the log by adjusting up or down with the Hydraulic Wedge control lever.
  - Push to raise wedge
  - Pull to lower wedge
3. Push and release the center, green switch to start the cycle. Push block should completely extend and return automatically.
4. While a piece splits under the auto cycle control, you can advance the log in the feed trough and start the next cut. Always keep an eye on the splitter when you do this. DO NOT finish a cut until the push block has fully retracted.
5. If a hard-to-split piece stops or noticeably slows the push block, press and release the red stop button.
6. If you have to stop the push block in mid cycle, next push the black retract button. That button makes the push block return to it's start position and resets the splitter to begin a new cycle. Use your judgement when that happens. You can split some pieces just by starting the push block forward again; some pieces need to be repositioned or turned around; some need to be removed.

You can start cutting the next piece before the push block returns to its retracted position.



### CAUTION

**Never finish a cut before the push block returns completely to its retracted position.**

Continue as previously instructed.

These operating instructions are designed as a guide for you. In time you will become proficient.

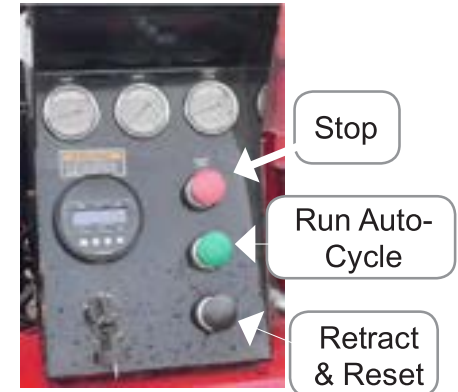

Electric Auto Cycle  
Switches

# Take Down Procedures

## Shutting Petcocks

Petcocks on the processor's hydraulic, fuel, and lubricant lines should be closed when the machine is secured for transport. During take down, check to make sure petcocks are closed on:

- Hydraulic lines
- Diesel fuel line
- Chain oiler



Petcocks

## Processor Shut Down

Timberwolf Firewood Processing Equipment firewood processors are easily moved between work sites. With live deck retracted, processors meet the normal size limits for travel on public roads:

Shutting the processor down for a move requires special attention:

- Make sure feed trough, log carriage, and hopper are clear of scraps and debris
- Close petcocks on:
  - Hydraulic tank, supply and return
  - Diesel fuel line
  - Chain oiler

## Live Deck Retraction Via Hydraulic Lift

The Hydraulic Deck Lift is available as an option on the PRO-MP XL, PRO MX, PRO-HD, PRO-HD XL and only. Instructions for live deck retraction using the hydraulic lift are as follows:

1. Make sure the processor's engine is running.
2. Push the hydraulic deck lift lever up (see right) to slowly and carefully raise the live deck until it is just about two feet off the ground so that you have room to comfortably fold the legs up.
3. Remove the deck leg's retainer pin from its locking position at the head of the deck strand.
4. Fold the leg back into its storage housing and secure by reinserting retainer pin through housing and leg itself. Secure retainer pin with hairpin. Repeat as necessary for remaining legs.
5. Using the deck lift lever, continue to lift the live deck until the deck strands are perpendicular to the ground, ensuring that the transport arm is securely guided into its housing on the transport mast.
6. Secure transport arm into its housing at the base of the transport mast with retainer pin. Secure the retainer pin with its hairpin.

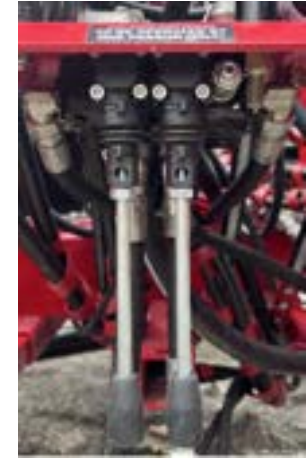

Hydraulic Deck Lift Lever

## Towing Procedures

### Firewood Processor towing weights and overall lengths/widths:

- PRO-MP — 5,560 lbs./18 ft. x 9 ft.
- PRO-MP X — 5,650 lbs./18 ft. x 9 ft.
- PRO-MP XL — 5,750 lbs./18 ft. x 9 ft.
- PRO-HD — 8,500 lb./30 ft. x 9 ft.
- PRO-HD XL — 9,000 lb./30 ft. x 9 ft.

### Tow vehicle equipment requirements:

- Hitch – 2 5/16 inch ball coupler or pintle hitch
- Electric brake controller
- Standard 7-pin wiring harness for lights and brakes
- 3/4 ton or larger truck

### Connection Instructions

1. Fully retract back corner jacks so the tires and front corner jack support the processor.  
Use front corner jacks to lift the processor's coupler. To adjust jack height:
  - Use hand crank to manage jack height
  - Remove retainer pin hair pin, then retainer pin itself
  - Raise Jack Foot all the way up
  - Reinsert retainer pin and retainer pin hair pin

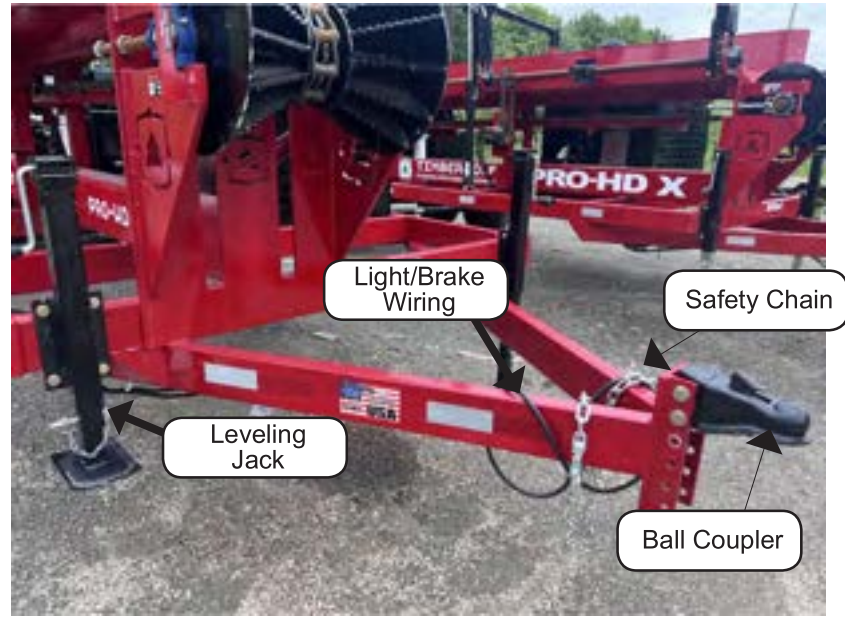

(Rear Towing/Leveling Assembly)



Front Corner Jack



## Towing Procedures (Continued)

- 1.5. **PRO-HD and PRO-HD XL models:** Dual axle processor models come equipped with two rear corner jacks. It is important to keep these adjusted to an even height when lifting the processor's coupler in order to ensure balance.
2. Back tow vehicle into position with its hitch under the coupler
3. Fully retract front corner jacks when coupler is securely positioned on tow vehicle's hitch
4. You may need to reposition the ball coupler so the processor has the correct tongue weight
5. Connect light and brake wiring harness, hitch failure emergency brake cable, and safety chains



### CAUTION

**Neve use the hitch failure emergency brake unit as a parking brake. Using the break-away brake as a parking brake while hitched to the tow vehicle will overload the electrical system and burn out the wiring. Using it will also drain battery when un-hooked.**

# Maintenance

## General

Good maintenance extends the processor's life and helps to ensure efficient operation.



### **WARNING**

**Make sure engine is shut off and hydraulic system is depressurized before you perform any maintenance. Read “Safety” section of this manual before performing any repairs.**

**For engine maintenance schedules, consult the engine owner's manual.**

## Daily Maintenance

Make maintenance a regular part of daily operation. The daily maintenance routine needs to include:

- Check –
  - Fluid levels:
    - Diesel fuel – start the day with a full tank
    - Plan to use one gallon per cord of firewood
    - Use 60/40 diesel fuel/kerosene mix in winter weather (30° F and below)
  - Hydraulic oil
  - Chain saw bar oil – use 30 weight in summer, 10 weight in winter

(continued on next page)

## Daily Maintenance (Continued)

- Cutting chain condition – don't start the day with a dull or damaged chain
- Splitter wedge – sharpen regularly with file or grinder
- Hydraulic line condition – keep track of wear; save on downtime by replacing hoses before they fail
- Nuts, bolts, and fittings – make sure all are tight and secure, especially wear plate bolts on the push block
- Welds – check high-stress joints
- Cut off length gauge – adjust if necessary
- Grease –
  - Saw arbor arm
  - Splitter push block
  - Clamp mechanism
  - Live deck drive mechanism and feed chain mounts
  - Feed trough drive mechanism and feed chain mounts
  - Test emergency shut off switch

## Hydraulic Fluid

Timberwolf Firewood Processing Equipment recommends ISO 46 hydraulic fluid. Change hydraulic fluid every 500 hours under normal conditions. Change it immediately if it becomes contaminated.

Plan to replace hydraulic line filters whenever the hydraulic fluid is changed.

## Emergency Shut Off Switch

Check the emergency shut off switch (“panic button”) every day, using the following procedure:

1. Start the processor
2. Depress the emergency shut off switch
3. The power plant should shut down immediately

If the emergency shut off switch fails to function correctly, contact Timberwolf Firewood Processing Equipment immediately by calling 1-800-340-4386.



Emergency Shut Off Switch (“Panic Button”)

## Saw Arbor Bearing

1. Grease the saw arbor bearing every 4 to 6 hours of operation or once a day.
2. Insufficient lubrication could permit premature wear on the arbor, resulting in costly down time and repairs.
3. Turn engine on
4. Raise chain saw bar to the full upright position
5. Turn engine off
6. Locate grease fitting on the round sleeve between the saw bar and the motor mount
7. Administer one or two pumps of grease



Saw Arbor Bearing

### Push Block

Grease the splitter push block and check the wear plate bolts every 4 to 6 hours of operation. Replace wear plates as needed.

Good maintenance keeps the push block sliding smoothly for efficient operation and reduced wear.

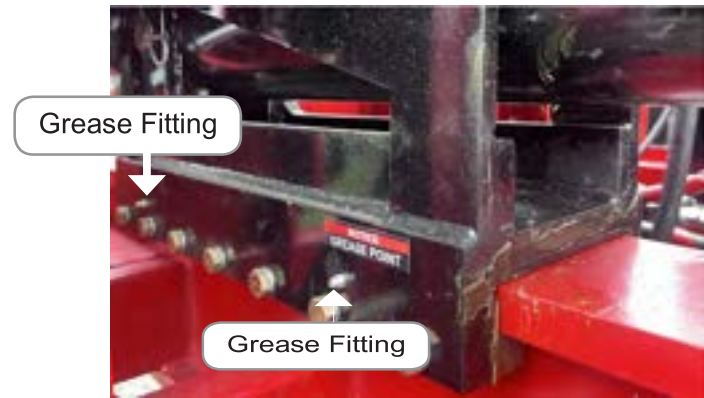

Splitter Push Block - Grease Fittings & Gibb Bolts  
(2 Grease Fittings, 5 Gibb Bolts On Each Side)

### Clamp

Grease the clamp mechanism every day. The photographs here show the top roll clamp system, which needs grease for the feed roller as well as for the vertical side rails.



Feed Roller Grease Fittings



Clamp Mechanism Grease Fittings  
Front and Back, Each Vertical Rail

## Live Deck

Grease the live deck components every day.

## Feed Trough Chain

Grease the chain mount bearing at each end of the feed trough.

Check the retaining collar set screws (two on each side) that secure the chain mount in the bearing. Make sure that they are fully tightened.

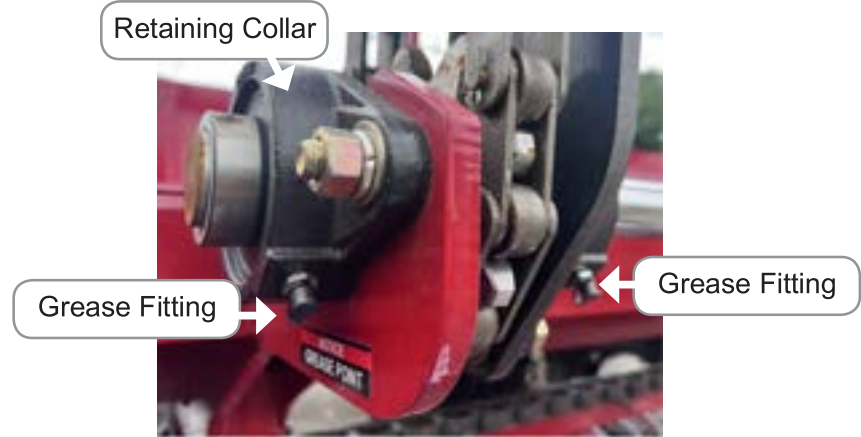

Live Deck Drive Mechanism –  
Two Grease Fittings On Each Drive Gear

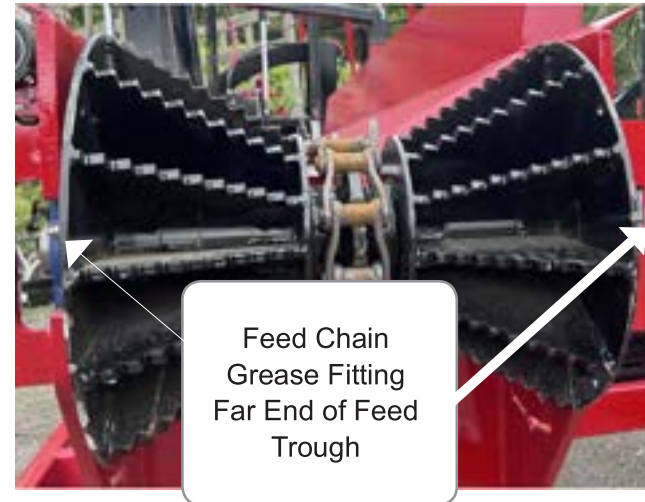
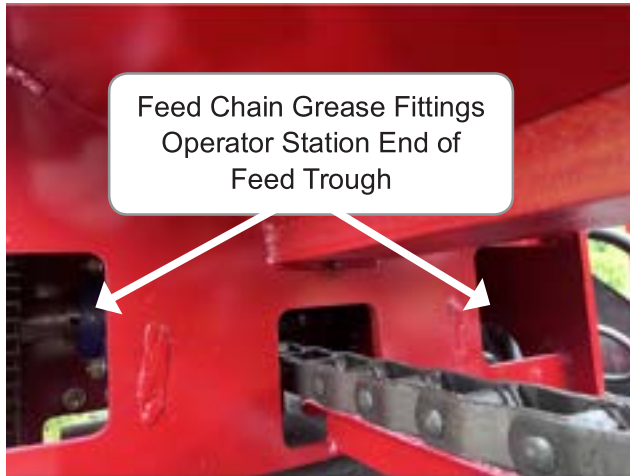

Feed Trough Chain Mounts – Four Grease Fittings Per Trough, Two at Each End

(continued on next page)



## Feed Trough Chain (Continued)

Check tension adjustment on the Feed Trough Chain. Chain should hang roughly 8 inches below the bottom of the trough at its lowest point. If chain hangs low, increase chain tension. Use a wrench to loosen the locking nuts, then turn the large chain tension set screws. The tension



Feed Trough Chain Tension



Feed Trough Chain Tension Set Screw

adjuster is located at the far end of the trough away from the operator. There are two set screws, one on each side of the chain, be sure to adjust them both equally. Re-tighten locking nuts.

## Auto Cycle Detent Valve Adjustment

**NOTE: Make all adjustments with the log splitter at normal operating temperature. There are several things you need to know before you adjust the auto-cycle valve:**

Make adjustments by turning the screw located on top of each valve (normally covered by black plastic protective cap).

(continued on next page)

## Splitter Auto-Cycle Valve Adjustment (Continued)

**NOTE:** Auto-cycle valve will not function properly if the **FORWARD** stop position (detente) is adjusted so the handles can be released before the log starts to split.

Normally both stop position screws (detentes) have to be adjusted to make the auto cycle work properly. Adjustment guidelines for auto-cycle valve detentes:

Correct adjustment requires you to hold both handles in their forward stop position (detente) until the log begins to split. You should then be able to release the handles while the push block automatically finishes advancing and retracts, completing the cycle.

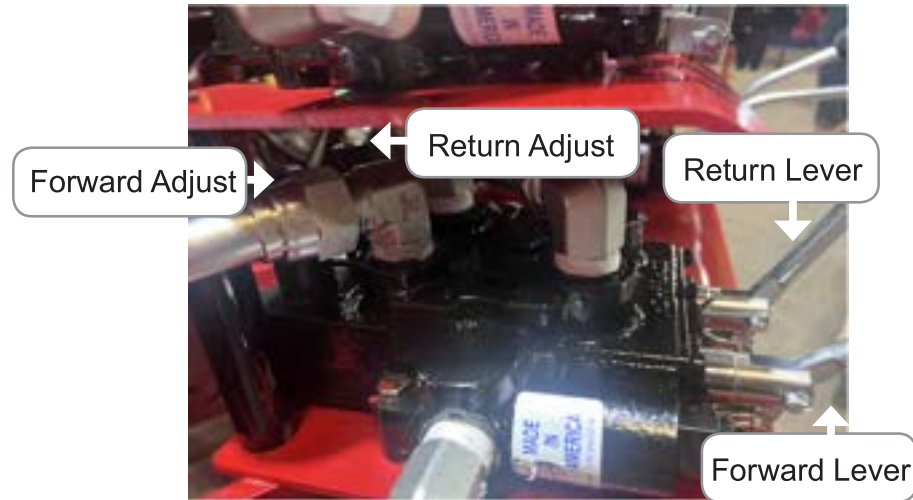

Splitter Subsystem Hydraulics

The stop position (detente) for each spool on the auto cycle valve must be adjusted periodically, depending upon use. If you're having problems making adjustments, the following information should help. As always, please call us if you have any questions or need help.

### Auto-Cycle Valve Adjustment Troubleshooting

**NOTE:** "Left" and "right" in the following instructions are the directions when looking at the valve from the operating handle (wedge) end.

#### Push block will not extend completely:

Adjust FORWARD spool (closest to the tank)

1. Loosen jam nut
2. Turn adjusting screw clockwise one-quarter turn
3. Tighten jam nut

*(continued on next page)*

## Splitter Auto-Cycle Valve Adjustment (Continued)

4. Split log to see if handle stays forward until the push block extends completely
5. Repeat adjusting and splitting until handle stays forward through the entire stroke

*NOTE: If the engine slows way down before it can kick the FORWARD lever into the neutral position, the adjusting screw is turned too far in. Make small adjustments until engine speed remains fairly stable while the FORWARD lever returns to neutral position.*

### **Push block will not return all the way OR Both handles kick to neutral when push block is all the way forward:**

Adjust RETURN spool (closest to the engine)

1. Loosen jam nut
2. Turn adjusting screw clockwise one-quarter turn
3. Tighten jam nut
4. Split log to see if push block will return on its own
5. Repeat adjusting and splitting until push block does return on its own

### **Right or left valve handle will not kick back to neutral position:**

1. Loosen jam nut
2. Turn detente sleeve counter-clockwise one-quarter of a turn at a time until handle kicks back to neutral
3. Tighten jam nut
4. If that doesn't work, shut down the log splitter, release system pressure, remove entire valve assembly, and check for dirt or broken parts

# Specifications

\* all specs subject to change without notice

PROCESSOR MODEL	PRO-MP	PRO-MP X	PRO-MP XL		PRO-HD	PRO-HD XL
POWER PLANT	GX 700	GX 800	38 HP Kohler		56 HP Hatz Diesel	74 HP Hatz Diesel
PUMP (gpm)	22-22	22-22	22-22-8		33-20-13	33-20-13
WEIGHT (lbs)	5,560	5,650	5,750		8,500	9,000
SAW (in)/ CHAIN GAUGE	25 Hydraulic/ .404	25 Hydraulic/ .404	25 Hydraulic/ .404		25 Hydraulic/ .404	25 Hydraulic/ .404
TOP ROLL CLAMPING SYSTEM	STD	STD	STD		STD	STD
SPLITTER CYLINDER DIA. (in)	4/5	4/5	4/5		4/5	4/5
MAX LOG DIA. (in)	24	24	24		24	24
TROUGH LENGTH (ft)	16	16	16		16	16
MAX. LOG LENGTH (ft)	32	32	32		32	32
HYDRAULIC CAPACITY (gal)	30	30	30		70	70
LIVE DECK (Hydraulic)	STD	STD	STD		STD	STD
DECK SIZE (ft deep x ft wide)	8 x 6	8 x 6	8 x 6		8 x 12	8 x 12
HYDRAULIC OIL COOLER	N/A	OPT	STD		OPT	STD
ELECTRIC AUTO CYCLE	N/A	N/A	STD		OPT	STD
CYCLE TIME (sec)	6	5	4.5		7	4.5
4-WAY WEDGE	STD	STD	OPT		OPT	OPT
6-WAY WEDGE	OPT	OPT	STD		STD	OPT
8-WAY WEDGE	N/A	N/A	N/A		OPT	STD
DOT LIGHTS	STD	STD	STD		STD	STD
OPERATOR SEAT	OPT	OPT	OPT		OPT	OPT

## Assembly and Repair - Pro-HD, HD X, HD XL

With normal use of the processor, replacement parts and repairs may be needed. Reference the "Assembly and Repair" section for parts, part quantities and assembly instructions.

Pro-HD, Pro-HD X, Pro-HD XL



## PRO-HD, HD X, HD XL PUMP

Item No	Part No	Part Name	Qty
1	50000-20007	Permco 3 Stage Pump for HD	1
2	815-166	#20 JIC M to #20 ORB M	3
3	815-145	#12 JIC M to #16 ORB	2
4	815-155	#16 JIC M to #16 ORB M	1
5	.5x13 1.5	.5x13 1.5 Bolt	2
6	.5 Washer	1/2" Washer	2

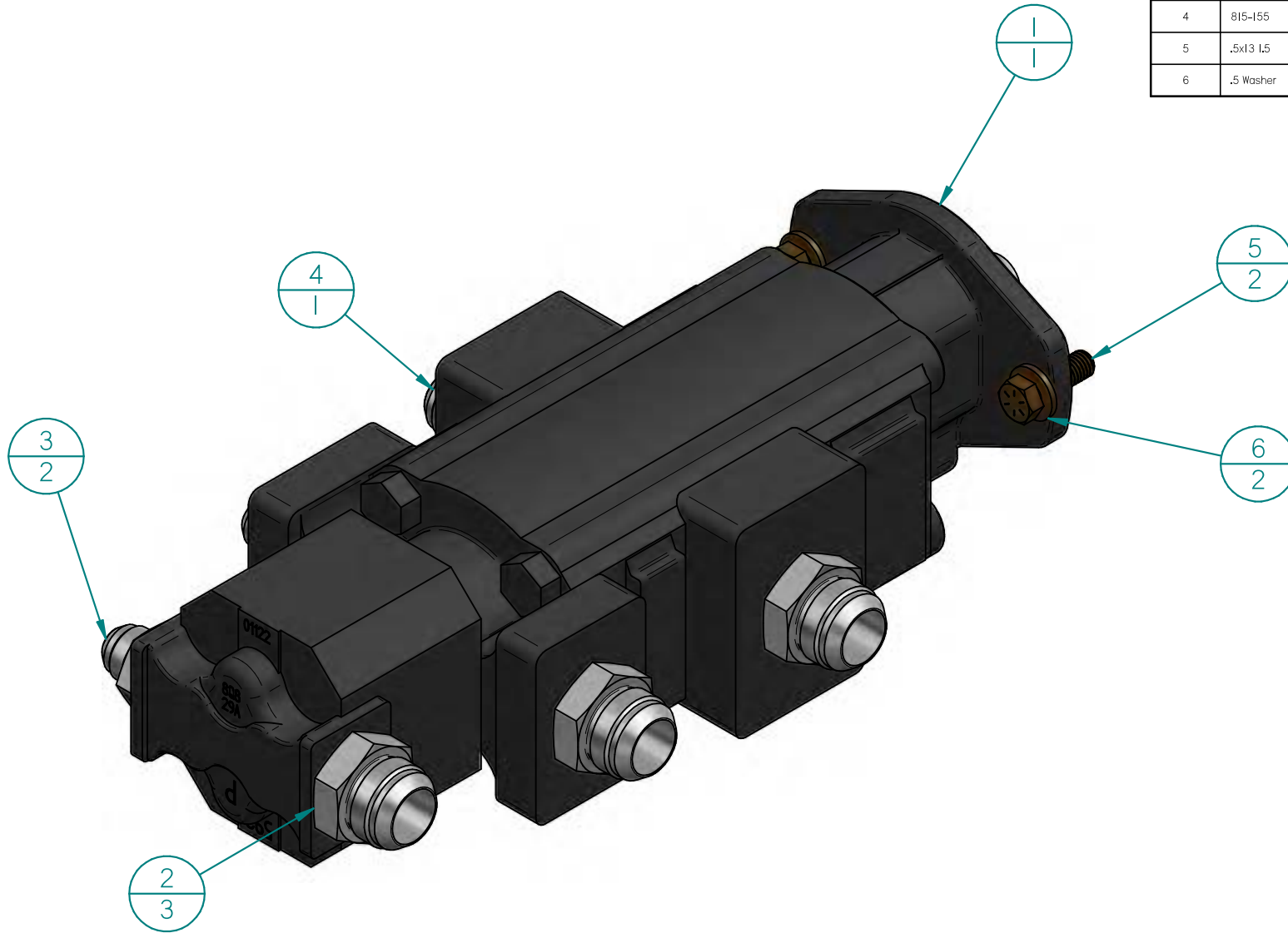



**PRO-HD XL SALAMI PUMP**

Item No	Part No	Part Name	Qty
1	50000-20016	Salami PRO HD Pump	1
2	815-144	#12 JIC M to #12 ORB M	2
3	815-155	#16 JIC M to #16 ORB M	1
4	815-165	#20 JIC M to #16 ORB M	2
5	815-166	#20 JIC M to #20 ORB M	1
6	.5 Washer	W1/2	2
7	.5x13 I5 Bolt	HHI/2X1.5	2

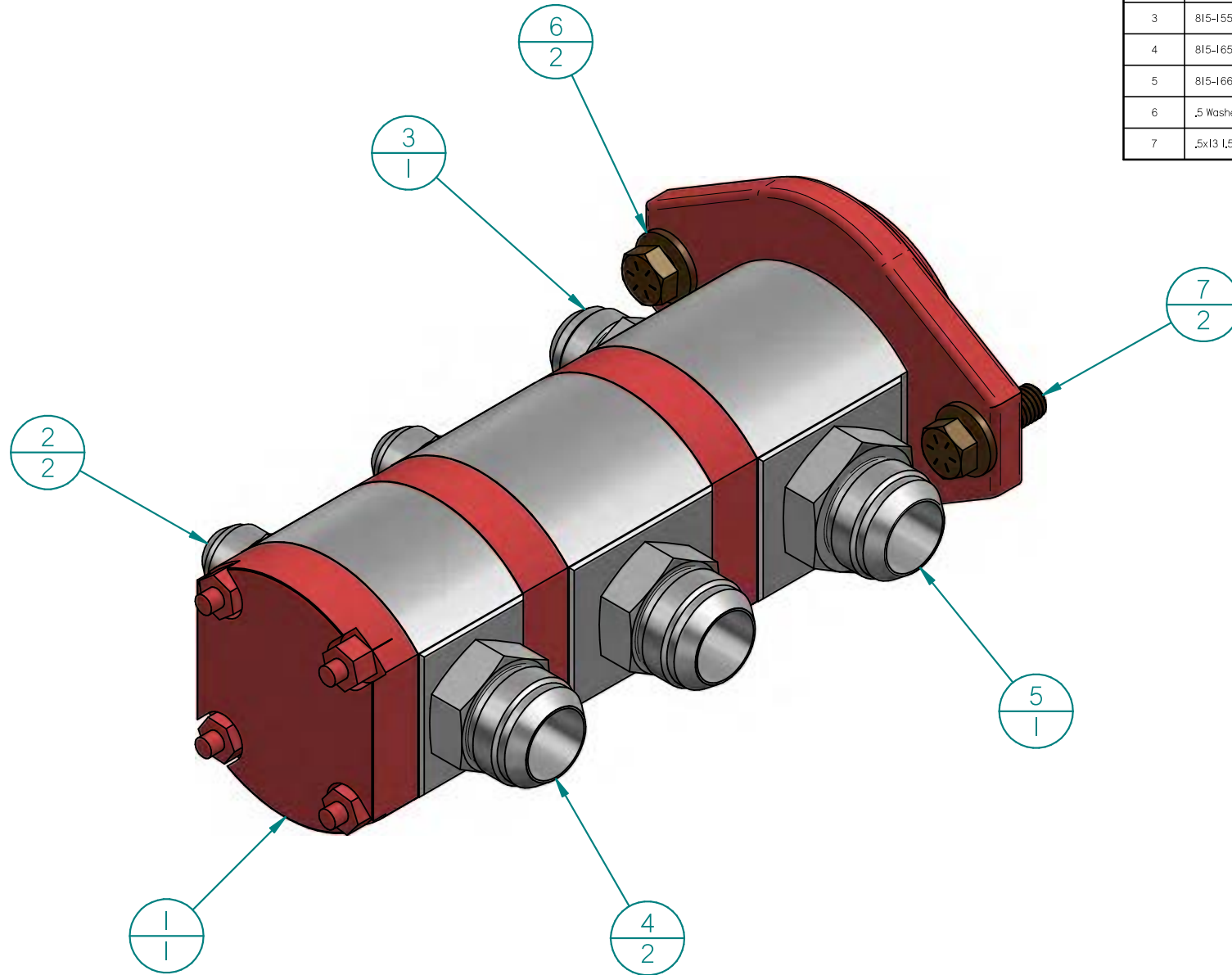

## PRO-HD, HD X, HD XL PUSH BLOCK CYLINDER

Item No	Part No	Part Name	Qty
1	901-017	5x26x3.5 Processor Cylinder 8-28-23	1
2	9000-0246	Pin 1.25D 6.622UL	1
3	9001-0071	Alpha Cylinder Pin 1.25"x9.688"	1
4	40000-10002	Zn Cotter Pin 3/16" x 1-1/2" L	4
5	902-003	Pro Regeneration Manifold ASM	1
6	815-155	#16 JIC M to #16 ORB M	2
7	815-255	#16 JIC M to #16 ORB M 90	2
8	800-172	#16 JIC JIC ORB Run Tee	1

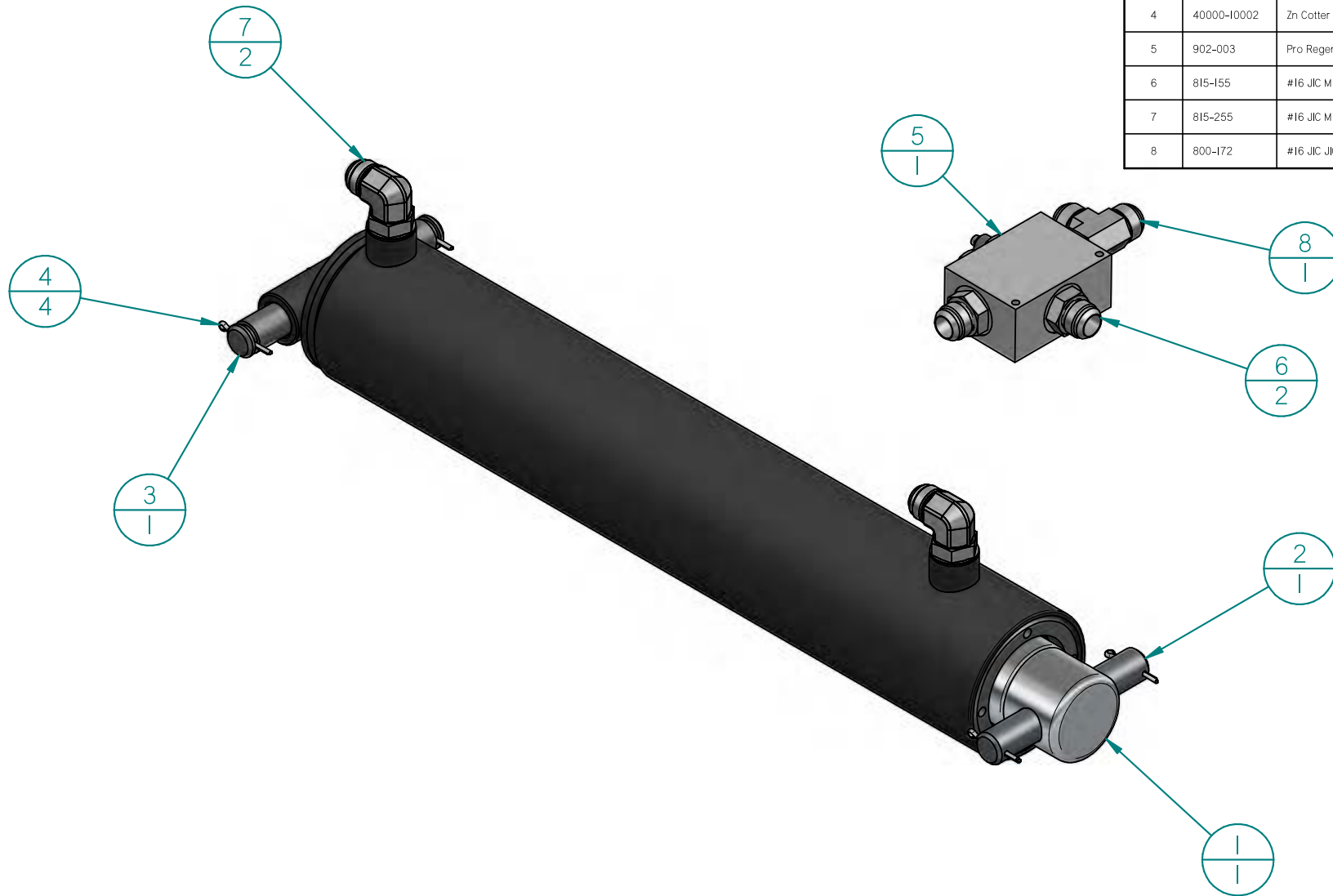

**PROCESSOR SAW BOX**

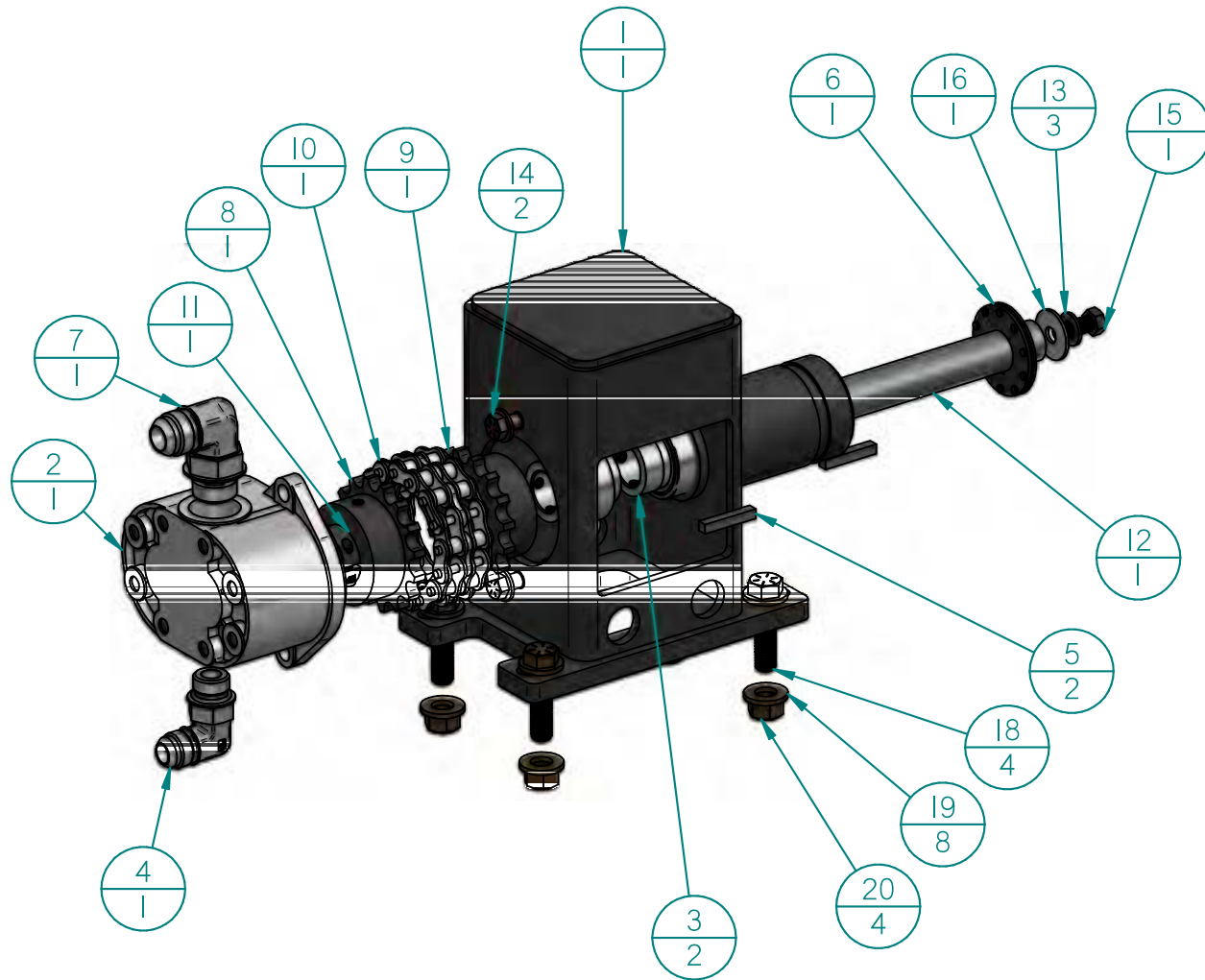

Item No	Part No	Part Name	Qty
1	9000-0256	Saw Box 11-28-23	1
2	50000-20012	Danfoss Saw Motor	1
3	30000-30001	Fosner 1100 K RR Arbor Bearing	2
4	815-233	#10 JIC M to #10 ORB M	1
5	10000-11012	1/4"x1.5" Key	2
6	30000-30015	Chain Saw Drive Sprocket 1"	1
7	815-244	#12 JIC M to #12 ORB M 90	1
8	30000-10005	0.75 Chain Coupler 5016	1
9	30000-10004	1" Chain Coupler 5016	1
10	30000-10003	5016 Double Chain	1
11	40000-10011	3/4" Shaft Collar	1
12	9000-0223	Saw Arbor Shaft ID 7.25L Keyed	1
13	W3/8	W3/8	3
14	HH3/8x1.5	HH3/8x1.5	2
15	HH3/8x1	HH3/8x1	1
16	FW3/8	W3/8, OD 1.25	1
17	N3/8	N3/8	2
18	HH1/2x2	HH1/2x2	4
19	W1/2	W1/2	8
20	N1/2	N1/2	4

## PROCESSOR SAW ARBOR ARM

Item No	Part No	Part Name	Qty
1	9000-0156	Arbor Arm 5-9-22	1
2	9000-0021	Pro Saw Backing Plate	1
3	9000-0020	Pro Saw Adjuster	1
4	30000-10013	Pro Saw Bar	1
5	875-100	#4 Hose Barb to #4 ORB M	1
6	9000-0155	Pin .75D 2.0625UL snap ring	1
7	30000-10012	.404 Chain	1
8		.75 Retaining Ring	1
9	N9/16	.5625 Nut	2
10	HH1/4x4G5	.25x20 4 Bolt G5	1
11	N1/4	N1/4	1
12	HH3/8x1	HH3/8X1	1
13	N3/8	N3/8	1
14	Grease Fitting 1/4	1/4 Grease Fitting	1

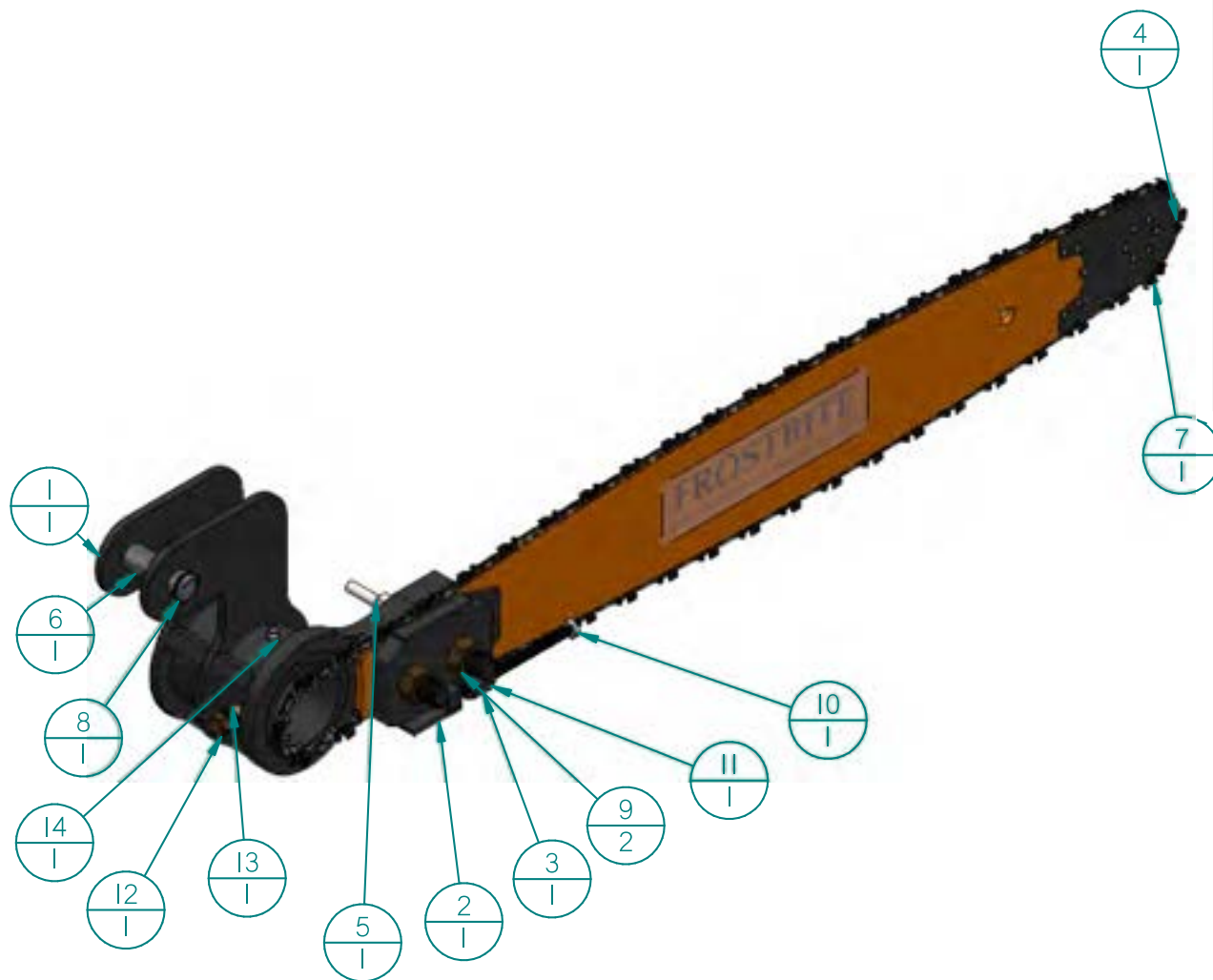

**PRO-HD XL SAW PISTON MOTOR MOUNT  
(OPTIONAL)**

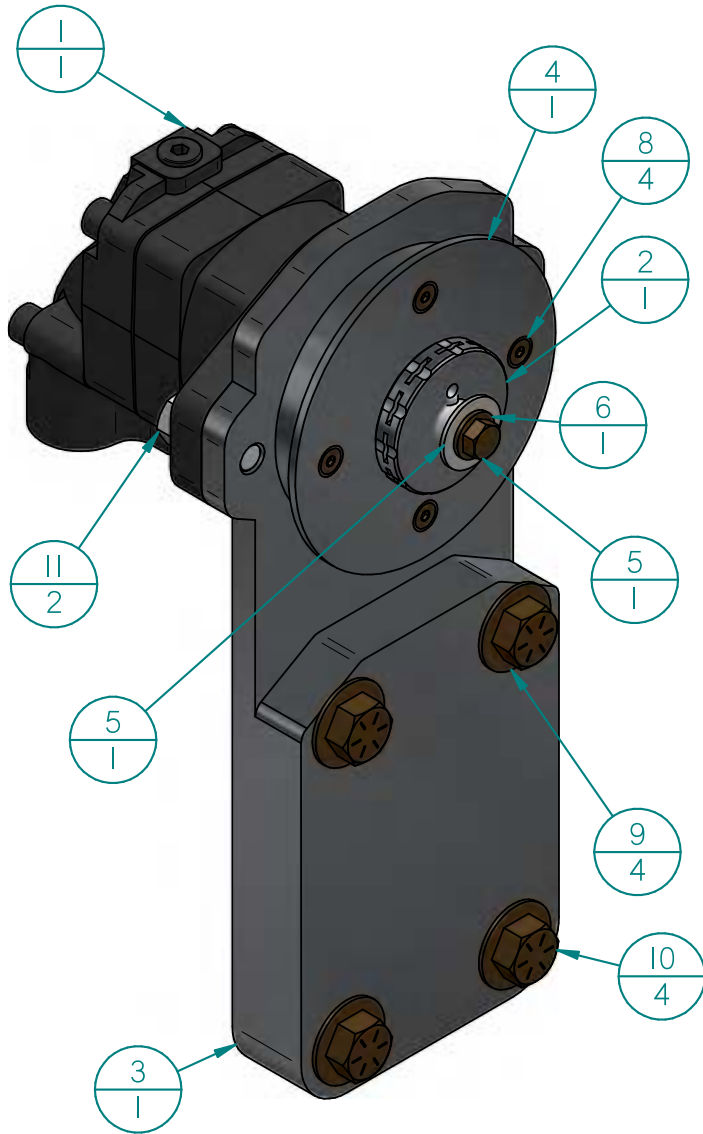

Saw guard bolts to this side of motor in gap seen

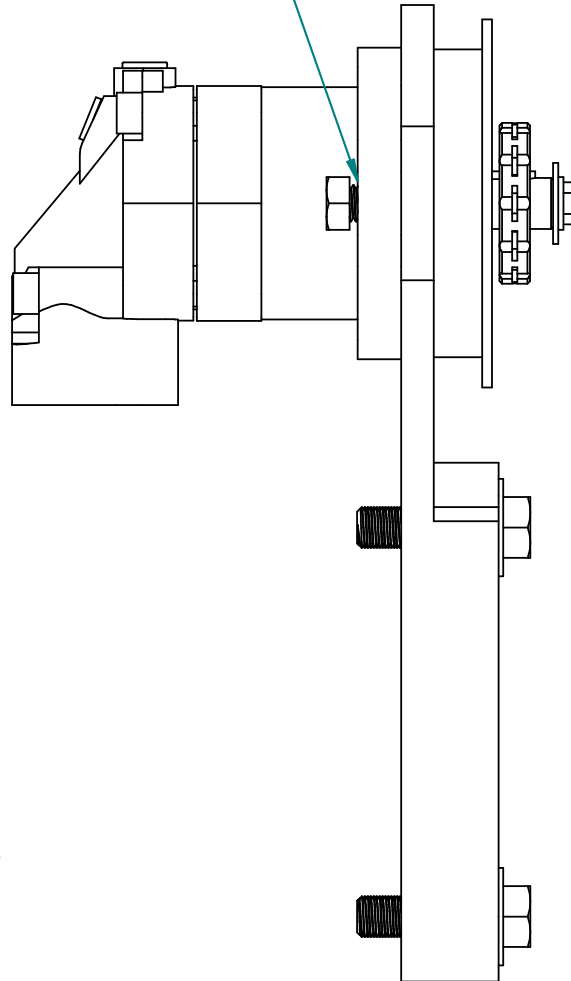

Item No	Part No	Part Name	Qty
1	50000-20022	Parker Bent Axis Motor	1
2	30000-30029	Chain Drive Sprocket .404 II tooth 20mm dia	1
3	259-359	Saw Arbor Boss Plate 5-22-24	1
4	259-360	Saw Arbor Retainer Plate	1
5	.375 Fender Washer	W3/8, OD L25	1
6	.375 Washer	W3/8	1
7	.375x16 I Bolt	HH3/8X1	1
8	.25x20 I Flat Head Bolt	.25x20 I Flat Head Cutting Screw	4
9	.625 Washer	.625 Washer	4
10	.625x11 2.25 Bolt	.625x11 2.25 Bolt	4
11	.5625x12 Bolt	HH9/16 2.5" bolt	2

Grease boss before putting the arbor arm on

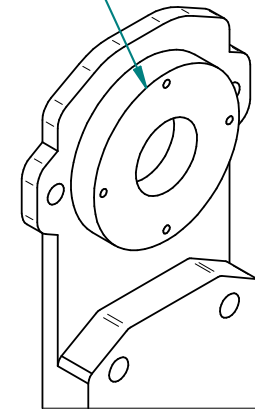

### PRO-HD XL SAW ARBOR ARM (OPTIONAL)

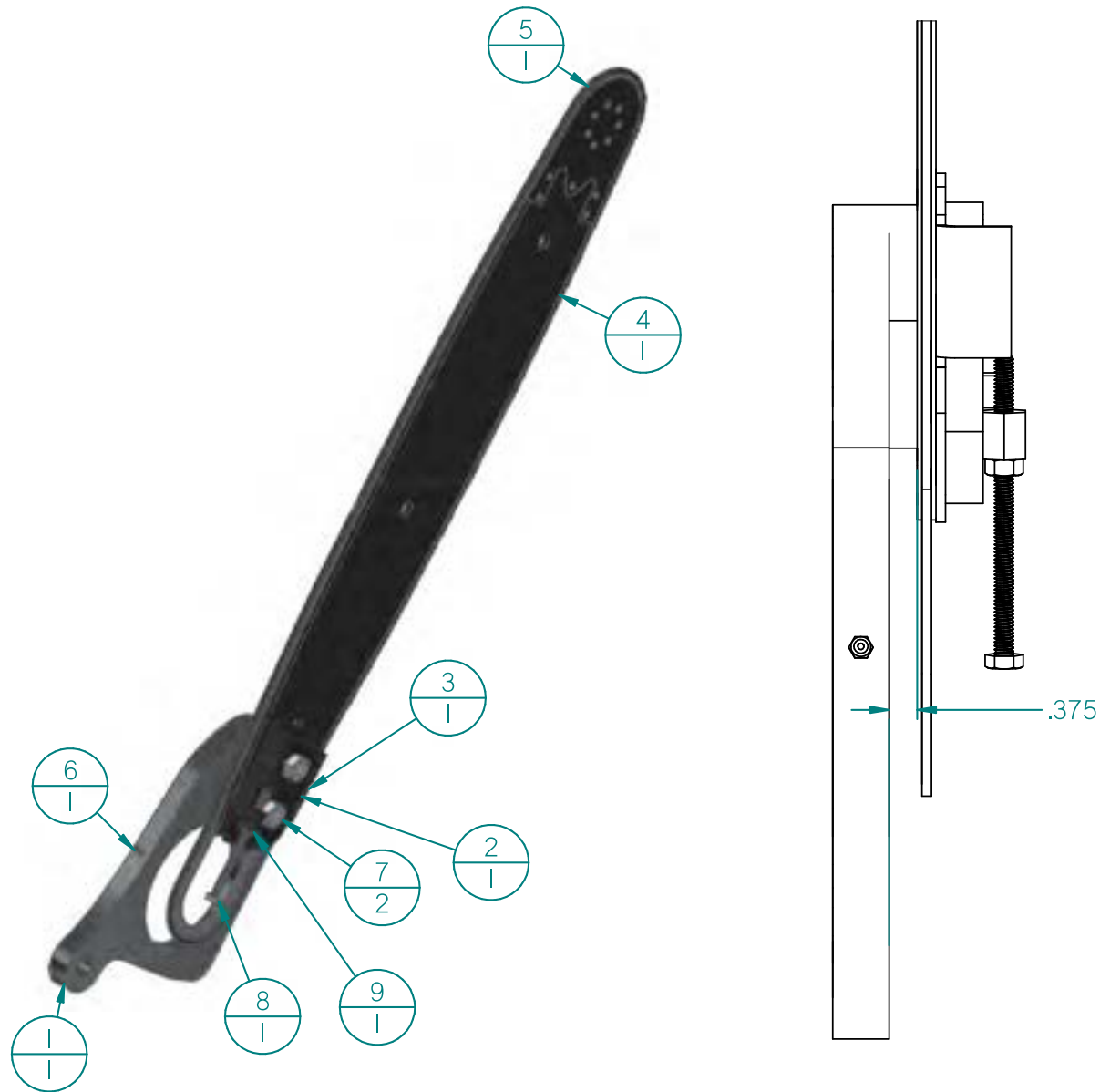

Item No	Part No	Part Name	Qty
1	9000-0294	Saw Arbor Pivot Plate 5-22-24	1
2	9000-0020	Pro Saw Adjuster	1
3	9000-0021	Pro Saw Backing Plate	1
4	30000-10015	Pro Saw Bar Gem GWX75 7	1
5	30000-10016	.404 pitch Saw Bar Chain 84 drivers	1
6	Grease Fitting 1/4	1/4 Grease Fitting	1
7	HH9/16x2	HH9/16x2 bolt	2
8	HH1/4x4G5	.25x20 4 Bolt G5	1
9	NI/4	NI/4	1



**PROCESSOR TOP ROLL SPAN**

Item No	Part No	Part Name	Qty
1	9000-0035	Pro Toll Roll Span	1
2	WI/2	WI/2	8
3	NI/2	NI/2	4
4	HHI/2x3,5	HHI/2X3,5	4

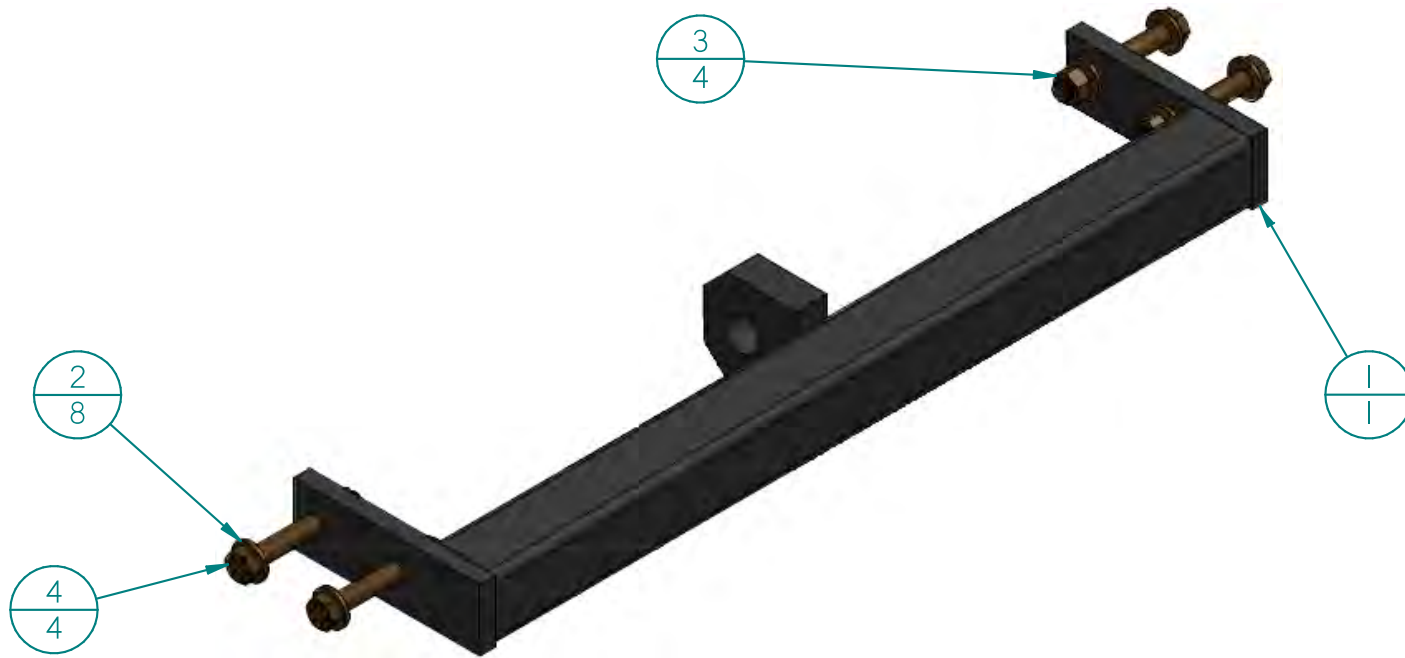

### PROCESSOR TOP ROLL CYLINDER

Item No	Part No	Part Name	Qty
1	256-008	2"x24" Cylinder #8 Ports	1
2	835-122	#8 NPT M to #8 ORB M	1
3	815-112	#6 JIC M to #8 ORB M	1
4	50000-10014	RD 1850 Pressure Relief	1
5	800-091	#6 TEE JIC M x JIC F Swi x JIC M	1
6	813-212	#6 JIC M to #8 M NPT 90	1
7	813-112	#6 JIC M to #8 NPT M	1

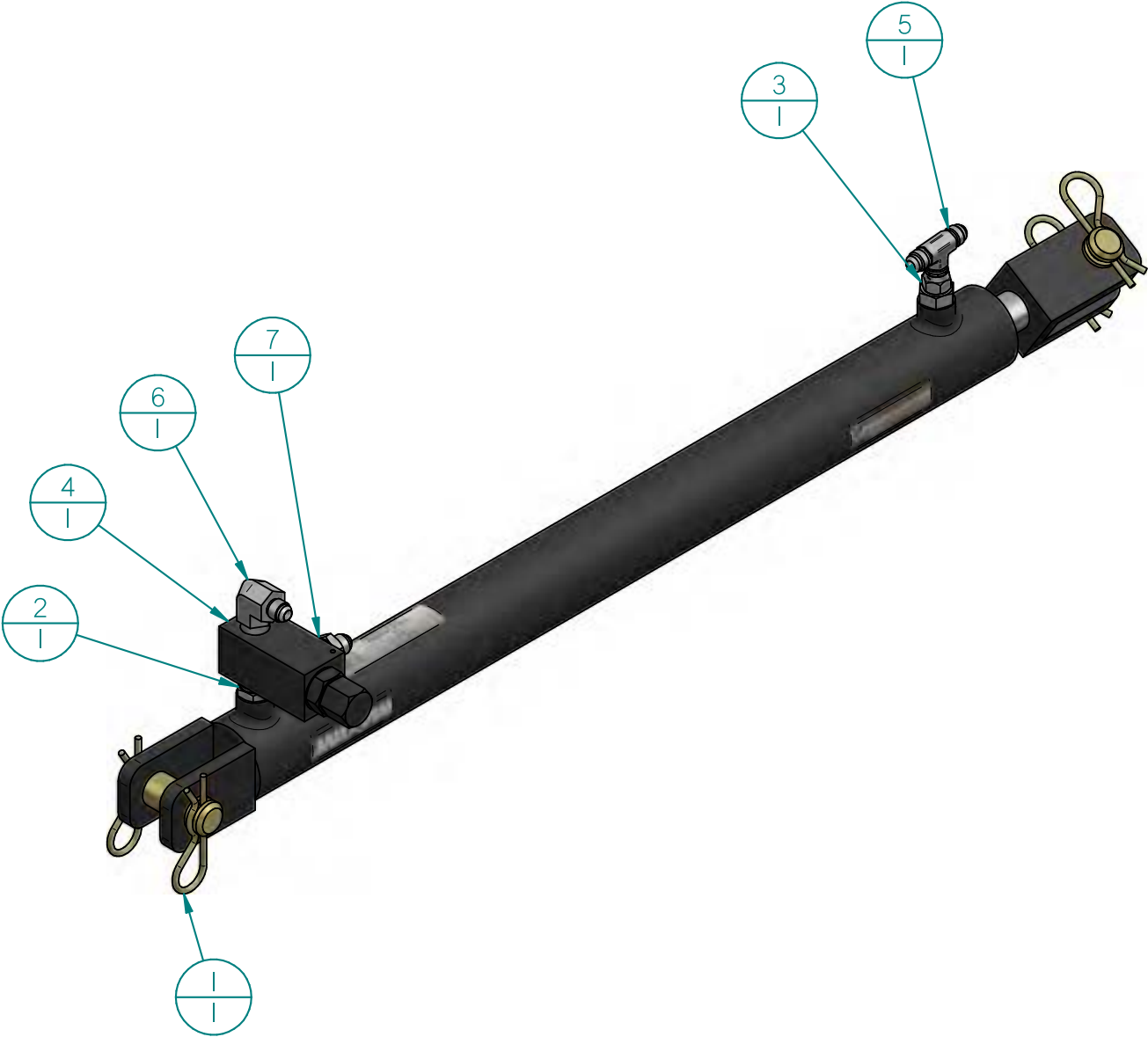

**PRO-HD CONTROL TOWER**

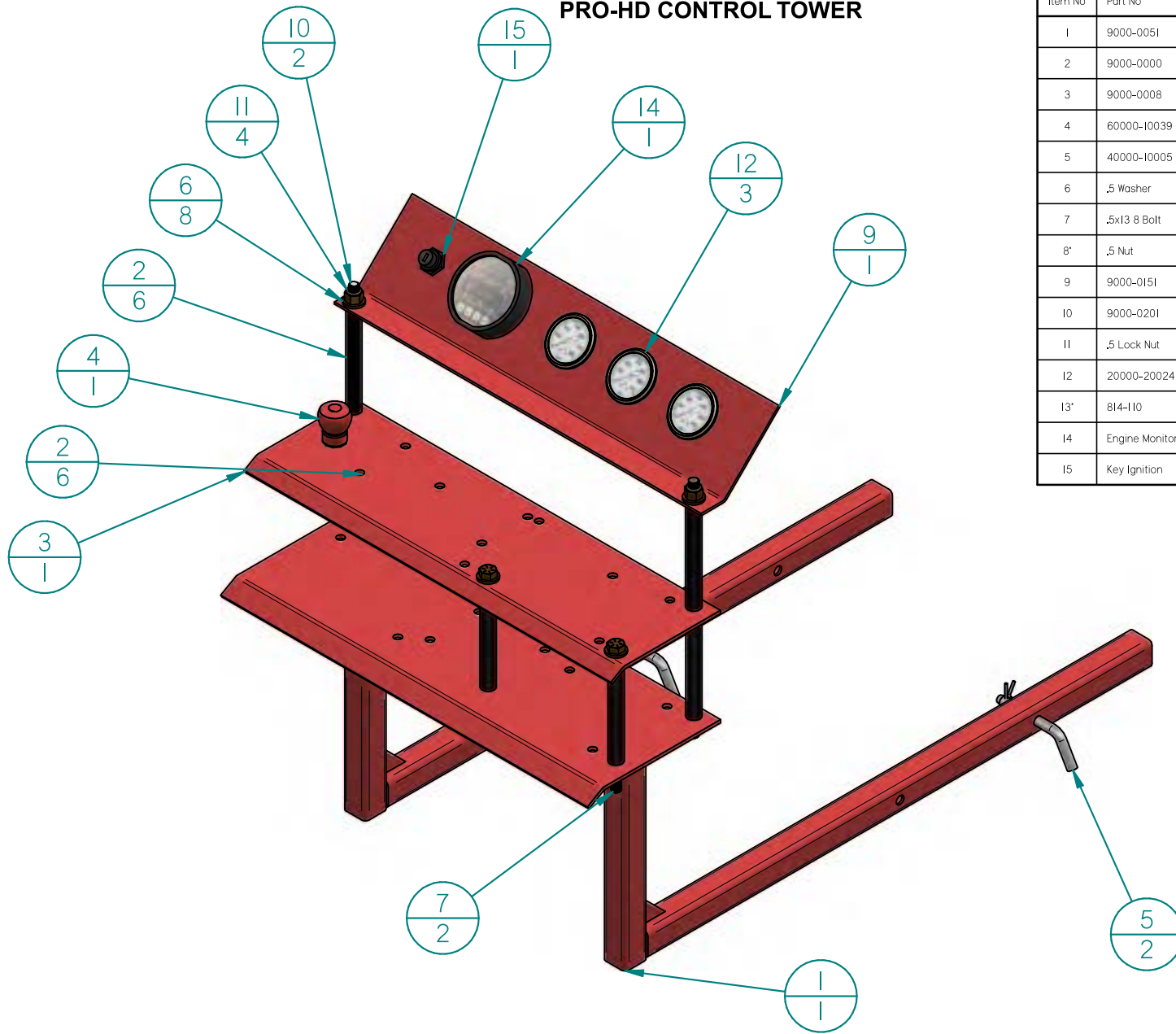

Item No	Part No	Part Name	Qty
1	9000-0051	Pro Control Tower	1
2	9000-0000	PRO HD Valve Stand Tube	6
3	9000-0008	Pro Valve Tower Top	1
4	60000-10039	E-Stop	1
5	40000-10005	Pull Pin 1/2" D x 3" UL	2
6	.5 Washer	W1/2	8
7	.5x13 8 Bolt	HH1/2X8	2
8	.5 Nut	N1/2	2
9	9000-0151	Pro HD Gauge Plate	1
10	9000-0201	Pro HD Gauge Plate Threaded Rod	2
11	.5 Lock Nut	NN1/2	4
12	20000-20024	5000 PSI Panel Gauge	3
13	814-110	#6 JIC M to #4 NPT F	3
14	Engine Monitoring Unit	Control	1
15	Key Ignition	Key Ignition	1

### PRO-HD X, HD XL CONTROL TOWER

Item No	Part No	Part Name	Qty
1	9000-0051	Pro Control Tower	1
2	9000-0000	PRO HD Valve Stand	4
3	9000-0008	Pro Valve Tower Top	1
4	60000-10039	E-Stop	1
5	40000-10005	Pull Pin 1/2" D x 3" UL	2
6	.5 Washer	1/2" Washer	8
7	.5x13 8 Bolt	.5x13 8 Bolt	4
8	.5 Nut	1/2" Nut	4

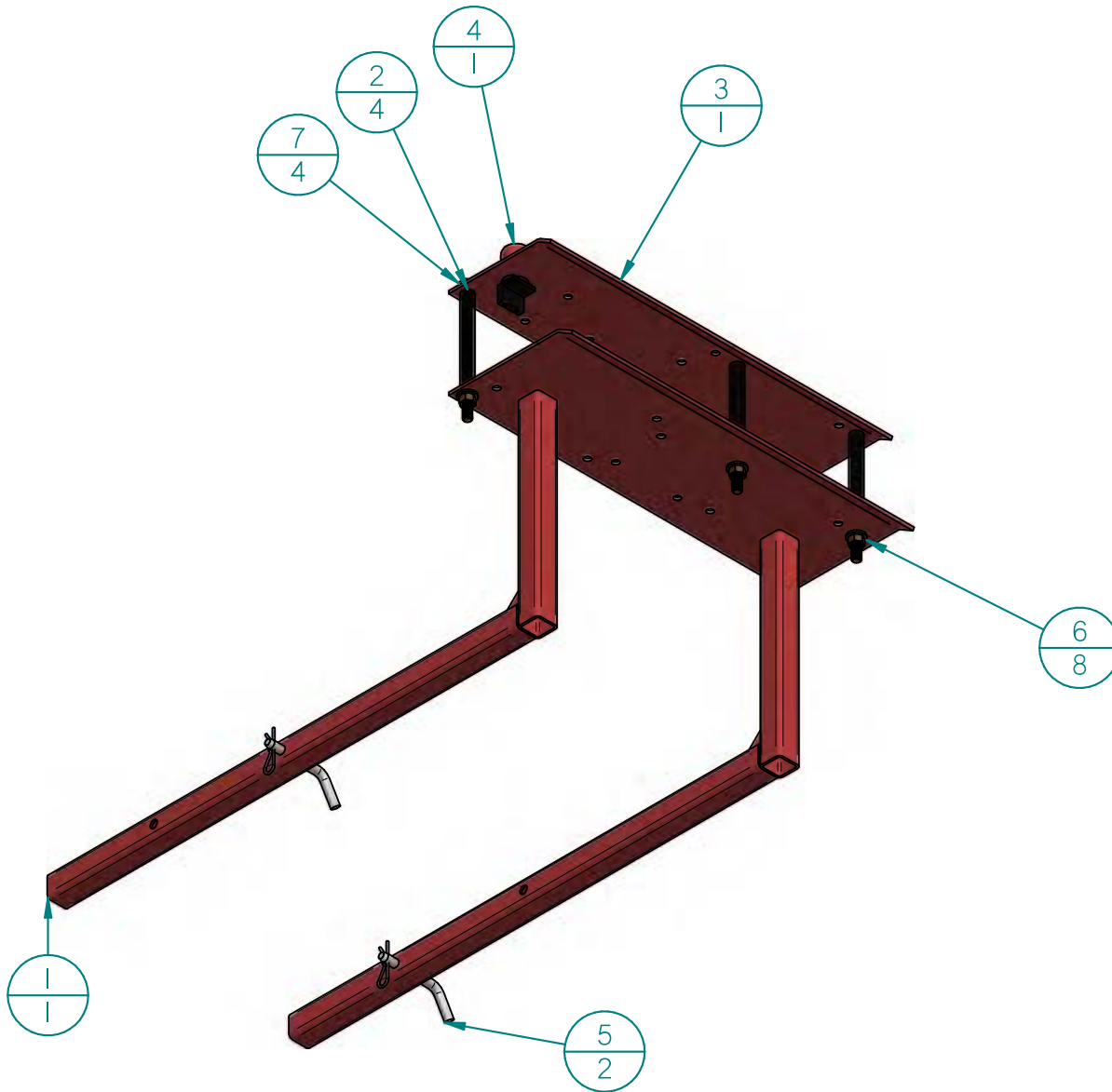

**PROCESSOR WEDGE CYLINDER**

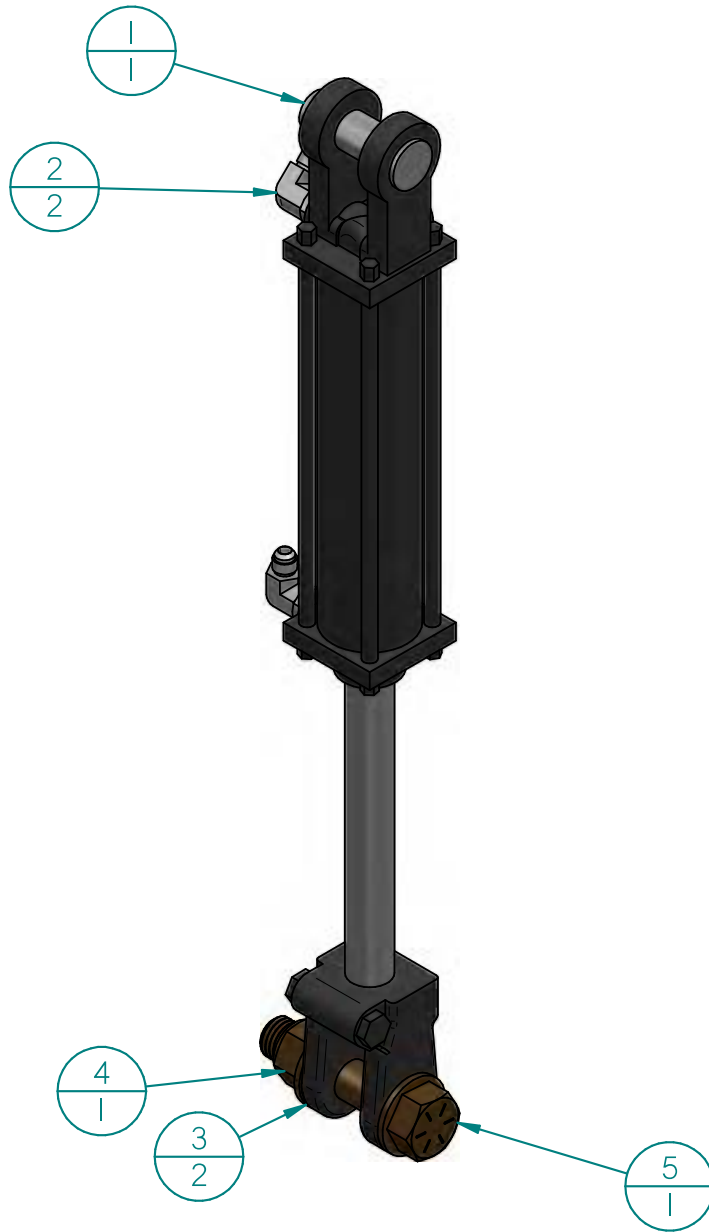

Item No	Part No	Part Name	Qty
1	50000-30003	2" x 8" Log Lift Cylinder HD	1
2	815-212	#6 JIC M to #8 ORB M 90	2
3	1 Washer	1" Flat Washer	2
4	1 Lock Nut	1 Lock Nut	1
5	1X8 4.5 Bolt	1X8 4.5 Bolt	1

## PROCESSOR TROUGH ROLLER

Item No	Part No	Part Name	Qty
1	262-353	Pro Trough Roller 1-22-24	1
2	30000-30003	1-1/2 Take Up UCT 208 Bearing	2
3	9000-0001	Pro Feed Trough Tensioner Bolt	2
4	1x8 Lock Nut	NNI	2
5	1x8 Nut	1x8 Nut	4
6	1 Cap Nut	1 Cap Nut	2

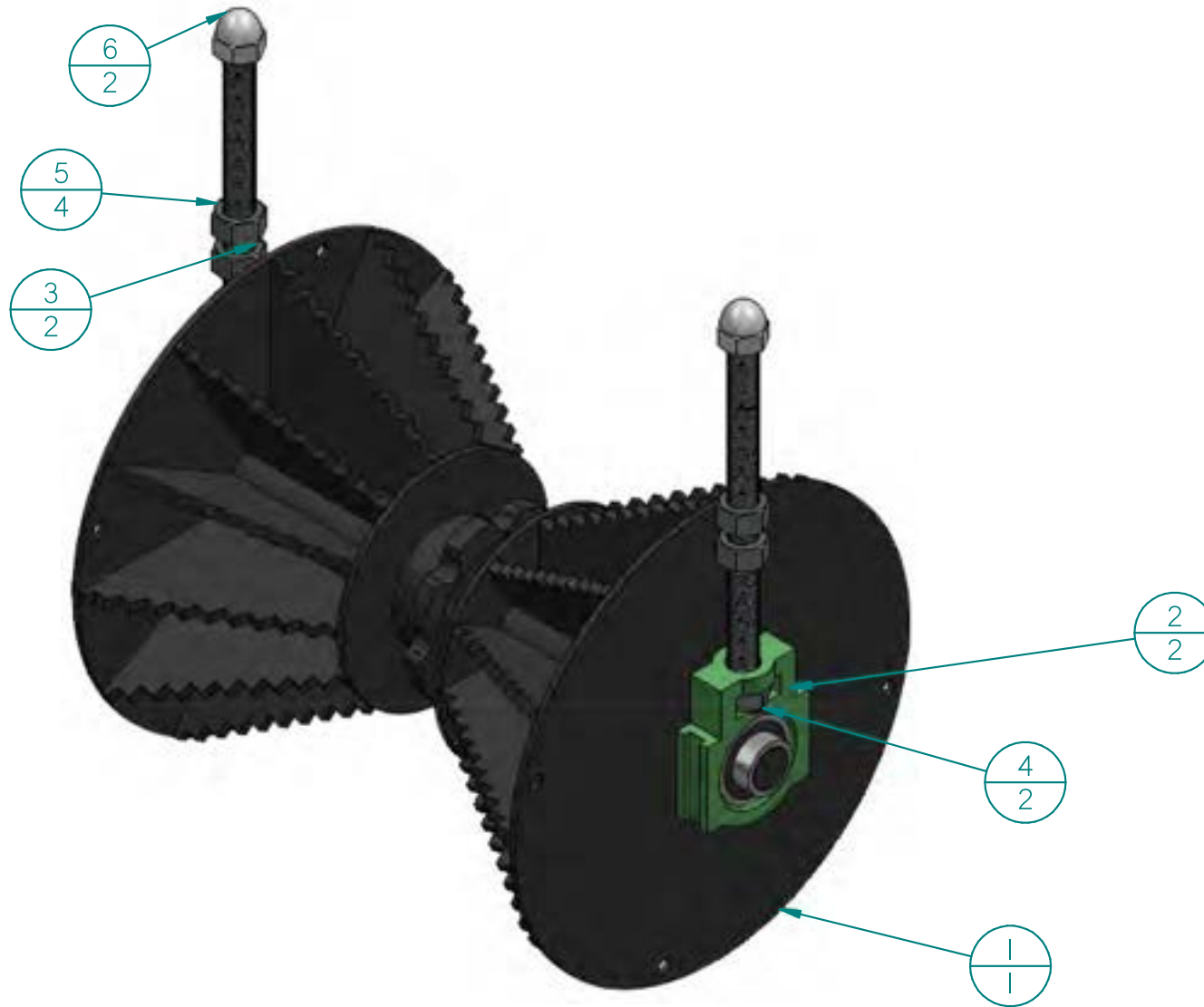

**PROCESSOR TOP ROLL UPRIGHT**

Item No	Part No	Part Name	Qty
1	9000-0235	Pro Top Roll Upright 8-11-23	1
2	20000-30000	#6 Soft Line Clamp Plastic	2
3	W1/2	W1/2	16
4	HH1/2x1.75	1/2"x1.75 Bolt	8
5	N1/2	N1/2	8
6	HH5/16x2	HH5/16x2	2

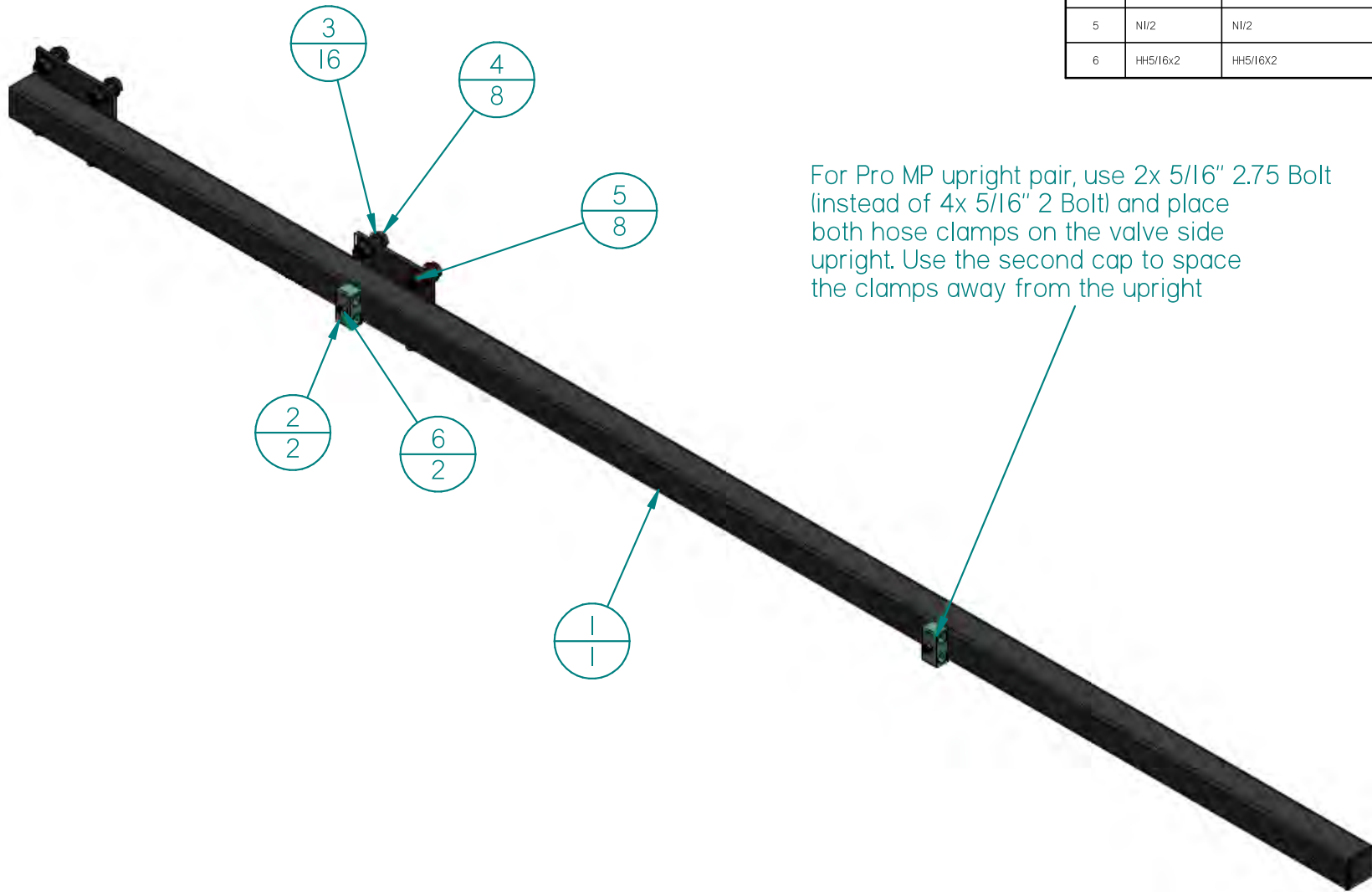

For Pro MP upright pair, use 2x 5/16" 2.75 Bolt (instead of 4x 5/16" 2 Bolt) and place both hose clamps on the valve side upright. Use the second cap to space the clamps away from the upright



## PROCESSOR TOP ROLLER

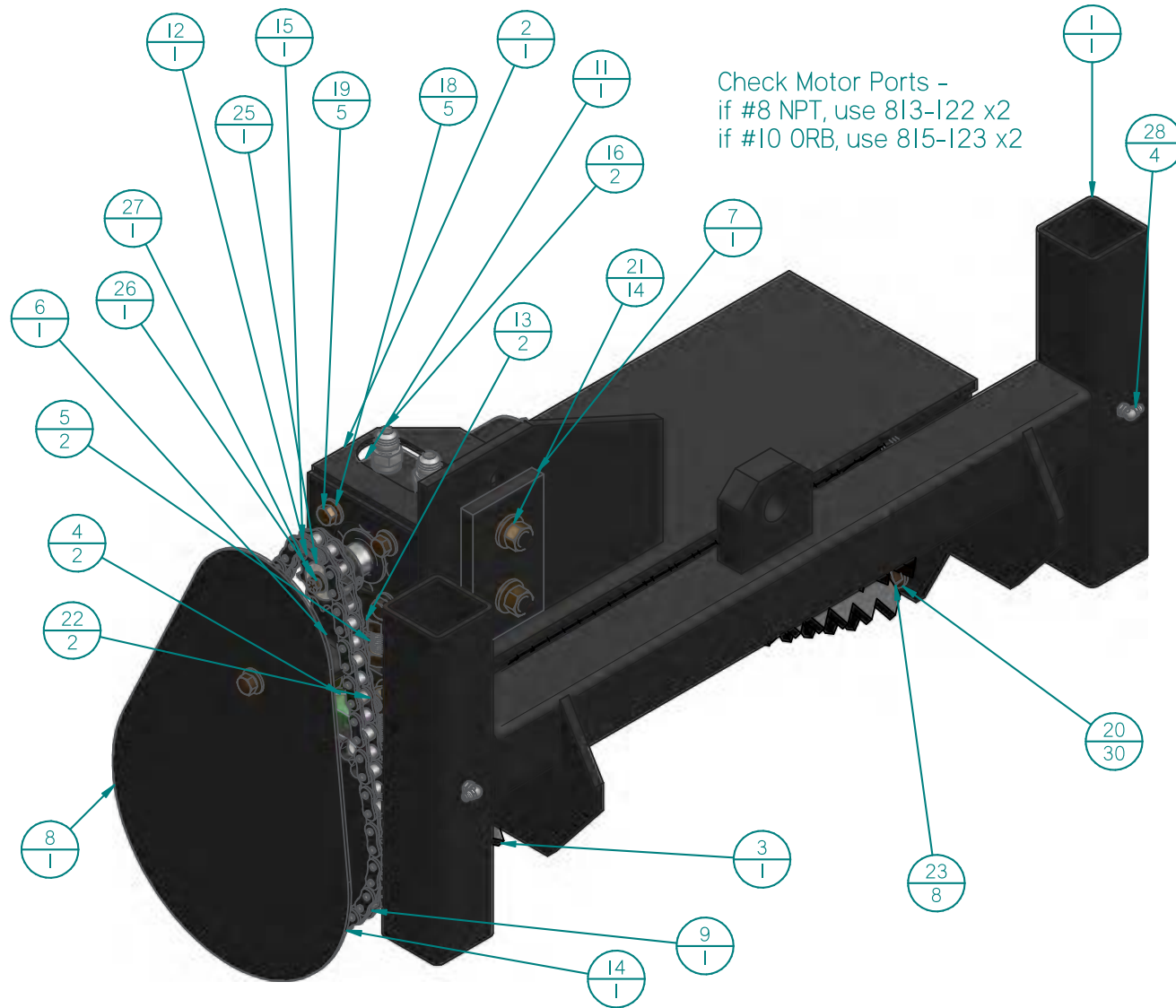

Item No	Part No	Part Name	Qty
1	9000-0121	Pro Top Roll Slide	1
2	9000-0130	Pro Top Roll Motor Mnt	1
3	9000-0055	Pro Top Roller	1
4	30000-30006	4 Bolt Flange UCF210-31	2
5	9000-0028	Top Roll Tensioner Block	2
6	9000-0011	Pro TR, Chain Guard	1
7	9000-0027	PRO TR Motor Adjuster Plate	1
8	9000-0030	Top Roller Chain Guard Finish	1
9	30000-20004	40 Teeth #50 Sprocket I-15/16	1
10*	Can Use 10000-11015	0.5x0.5x1.375 Key	1
11	50000-20009	Pro TR FT Motor	1
12	30000-20005	10 teeth #50 Sprocket Martin	1
13	9000-0002	Pro TR Tensioner Rod	2
14	Use: 30000-10002 x,75 total on processors for TR and FT drives	#50 Chain	1
15	30000-10010	#50 Master Link	1
16	813-122	#8 JIC M to #8 NPT M	2
17*	40000-10015	I-15/16 Shaft Collar	2
18	W3/8	W3/8	5
19	HH3/8x1	HH3/8X1	5
20	W1/2	.5 Washer	30
21	NI/2	NI/2	14
22	HH1/2x4	HH1/2X4	2
23	HH1/2X2,25	HH1/2X2,25	8
24	Grease Fitting 1/4 90	.25 Grease Fitting 90	4
25	FW1/4	.25" Flange Washer	1
26	HH1/4x75	HH1/4X3/4	1
27	W1/4	W1/4	1

**PROCESSOR TOP RIGHT VALVE**

Item No	Part No	Part Name	Qty
1	50000-10003	1 spool valve	1
2	815-124	#8 JIC M to #12 ORB M	2
3	815-113	#6 JIC M to #10 ORB M	2
4	.3125 Washer	5/16" Washer	6
5	.3125 Nut	5/16" Nut	3
6	.3125x18 2,25 Bolt	5/16"x18 2,25 Bolt	3

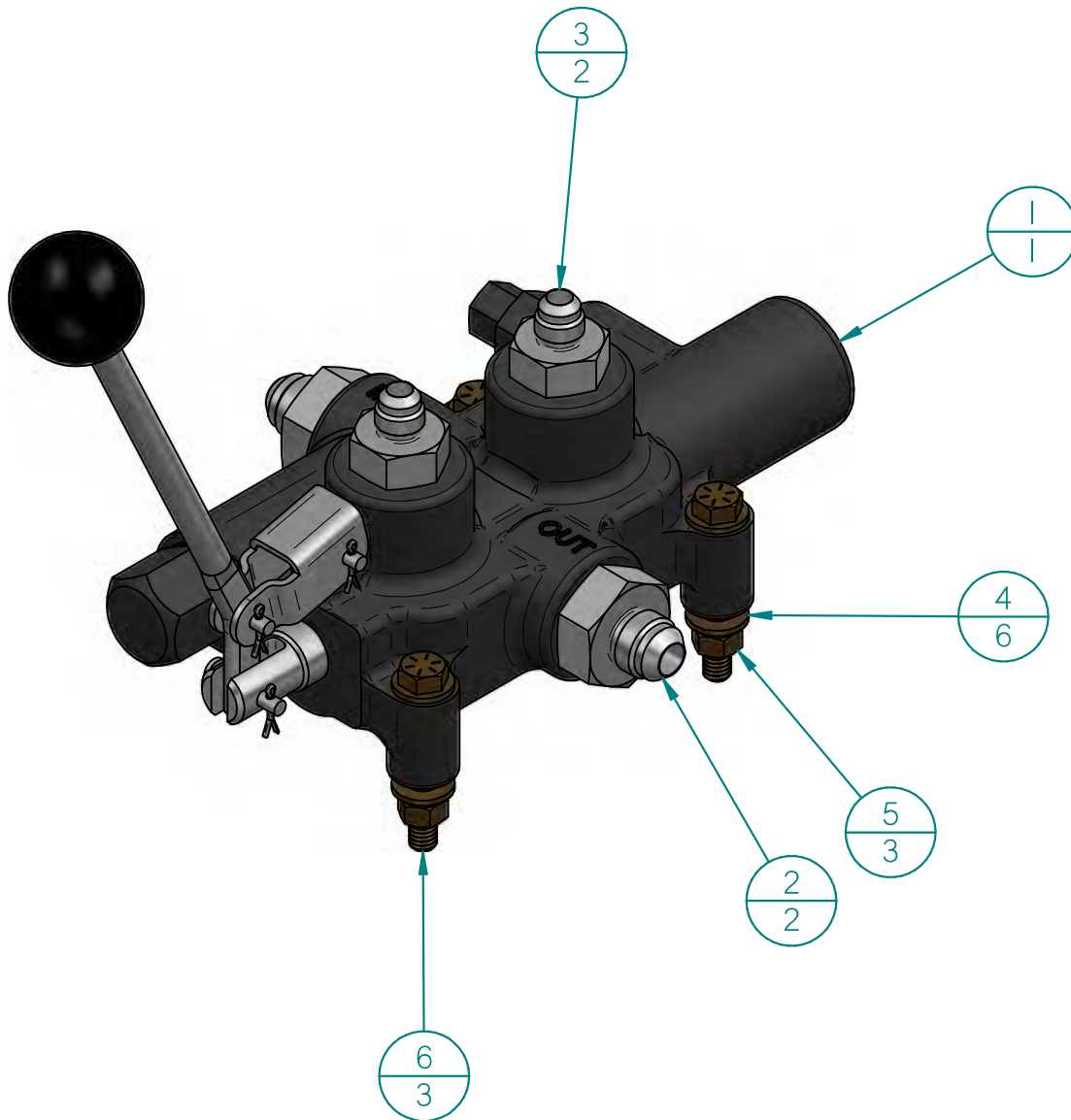

# PROCESSOR STOW BAR

Item No	Part No	Part Name	Qty
1	9000-0046	Pro LD Stow Bar	1
2	40000-10008	6" x 3/4" Pull Pin	1
3	40000-10005	Pull Pin 1/2" D x 3" UL	1



**PROCESSOR SPLITTER PLATE**

Item No	Part No	Part Name	Qty
1	9000-0267	Pro HD Tray Plate Left 10in L-24-24	1
2	FH3/8x2	.375x16 2 Flat Head	3
3	W3/8	W3/8	3
4	N3/8	N3/8	3

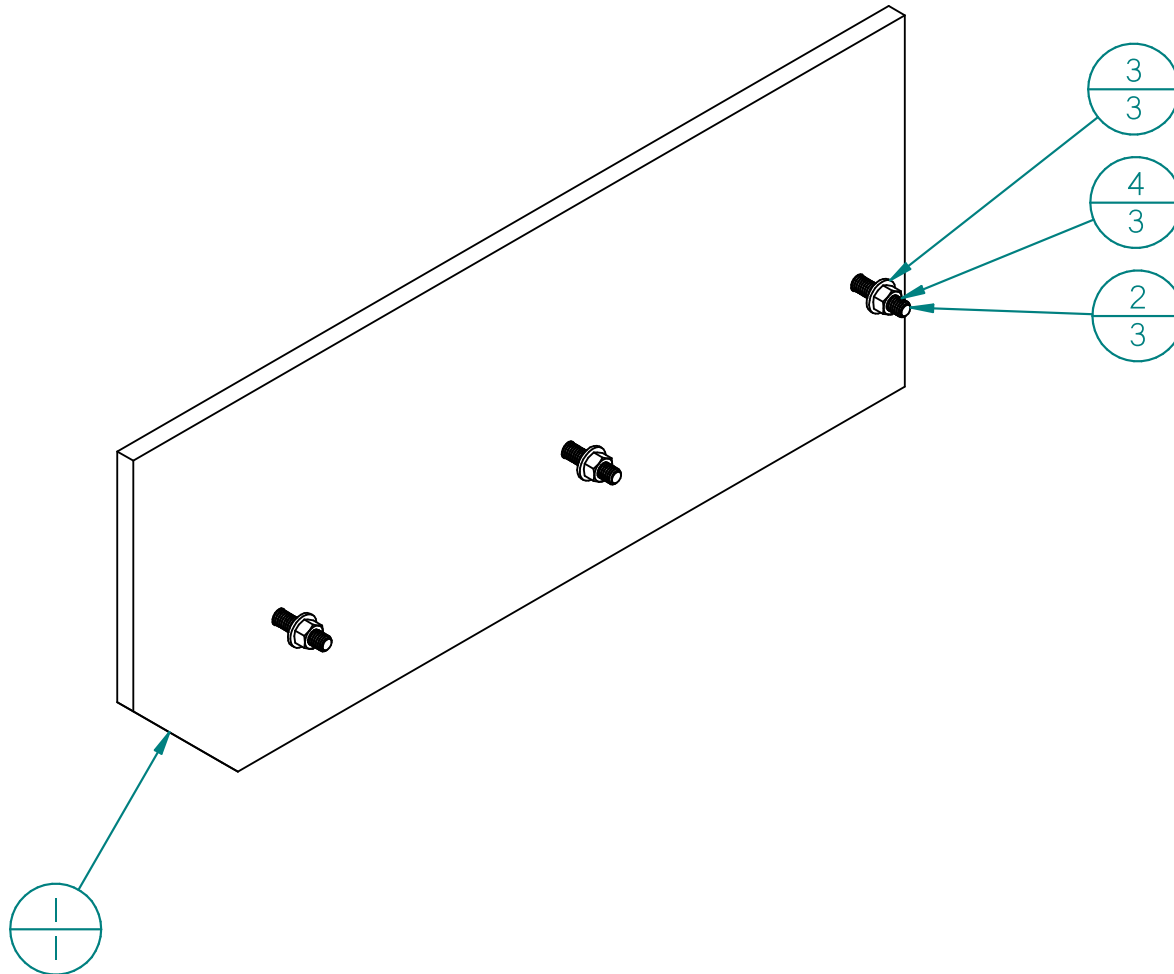

## PROCESSOR SAW GUARD

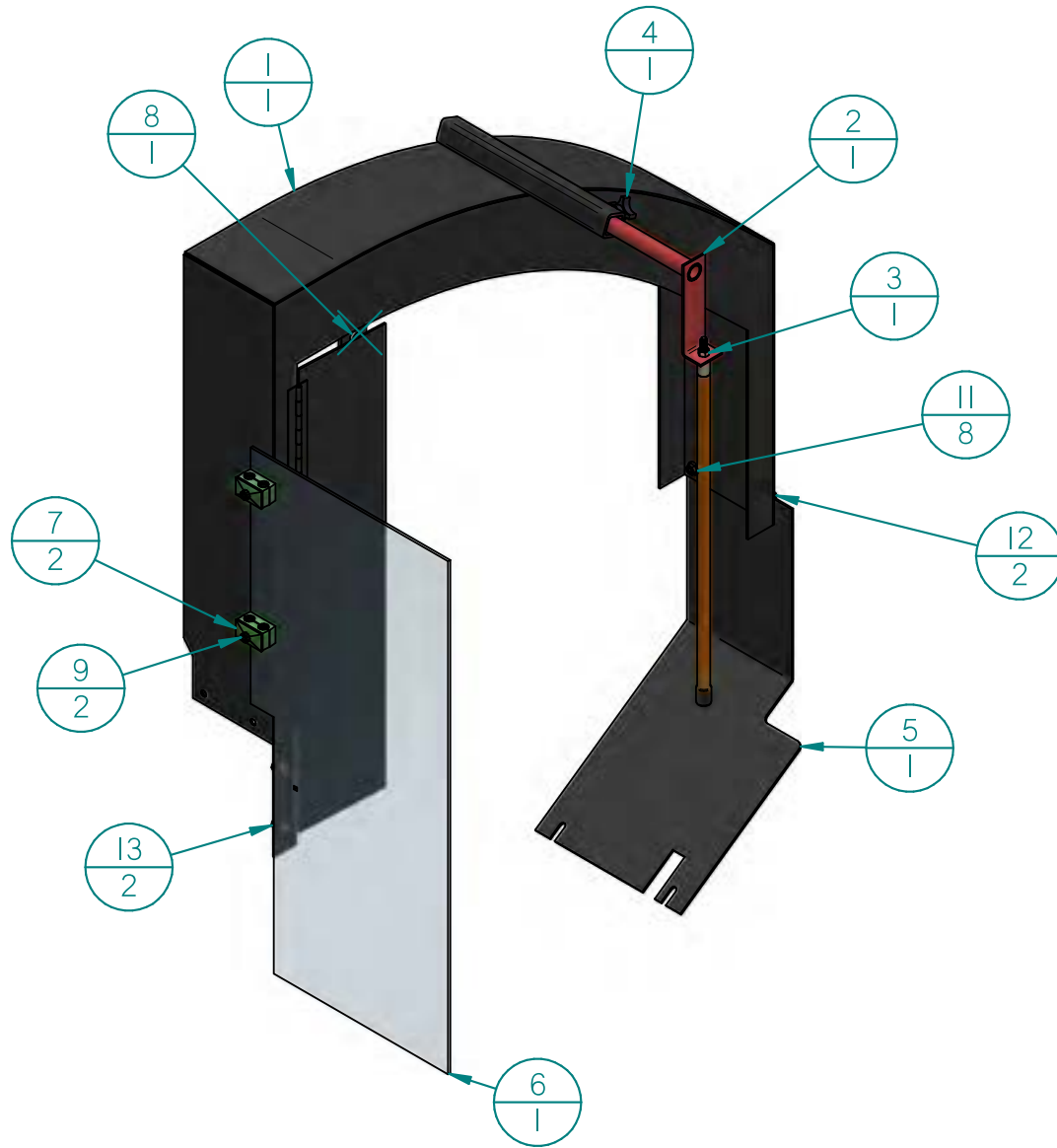

Item No	Part No	Part Name	Qty
1	9000-0226	Pro MP Saw Guard 8-24-23	1
2	9000-0127	Pro Guide Line Bar 11-22-21	1
3	10000-20000	Pro Guide Line Rod	1
4	40000-00014	Knob Stub Handle	1
5	9000-0032	Pro Bent Saw Shield Long	1
6	255-377	Pro Clear Shield - 0.333 of a sheet	0.333
7	20000-30000	#6 Soft Line Clamp Plastic	2
8	10000-20006	Encased Neodymium Magne	1
9	HH5/16x2	HH5/16X2	2
10	NN5/16	NN5/16	2
11	W3/8	W3/8	8
12	HH3/8x1,5	HH3/8X1,5	2
13	HH3/8x1	HH3/8X1	2
14	N3/8	N3/8	4

**PROCESSOR SAWDUST CHUTE**

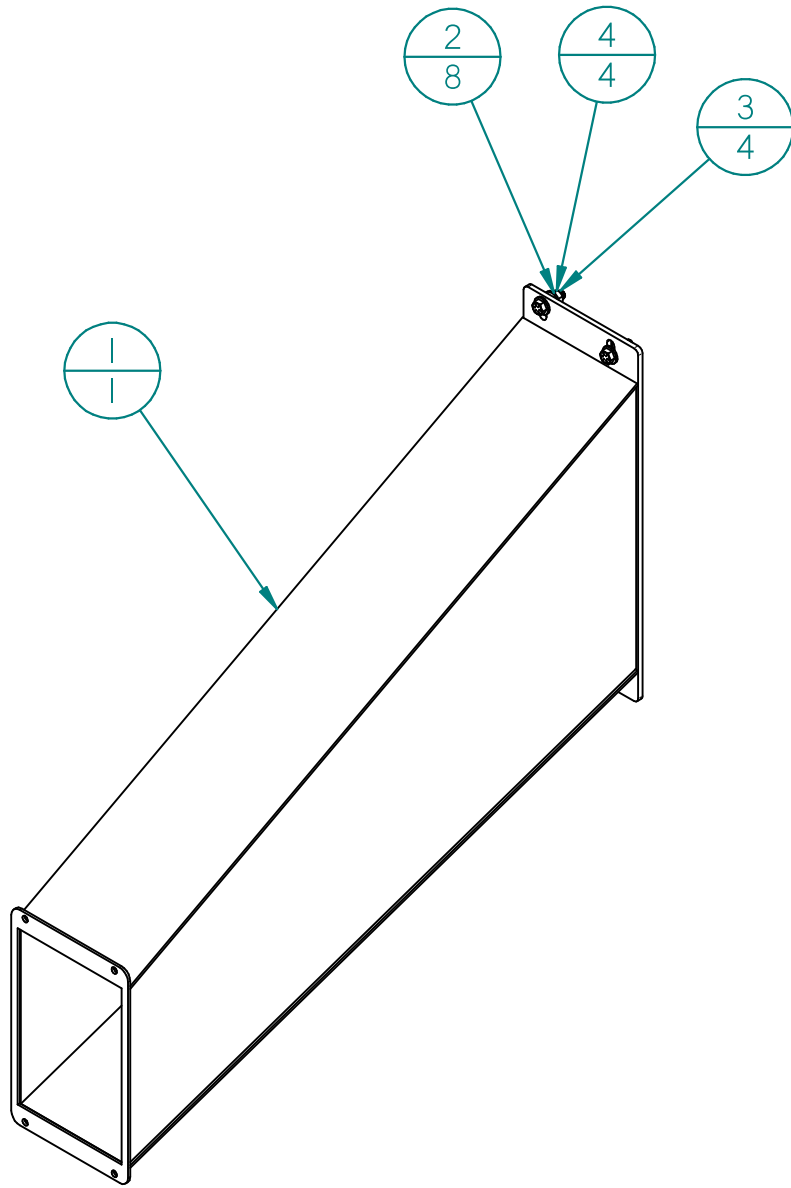

Item No	Part No	Part Name	Qty
1	9000-0228	Pro HD Dust Chute 8-24-23	1
2	W3/8	W3/8	8
3	HH3/8xL25	HH3/8xL25	4
4	N3/8	N3/8	4

### PROCESSOR SAW CYLINDER #4 ORB

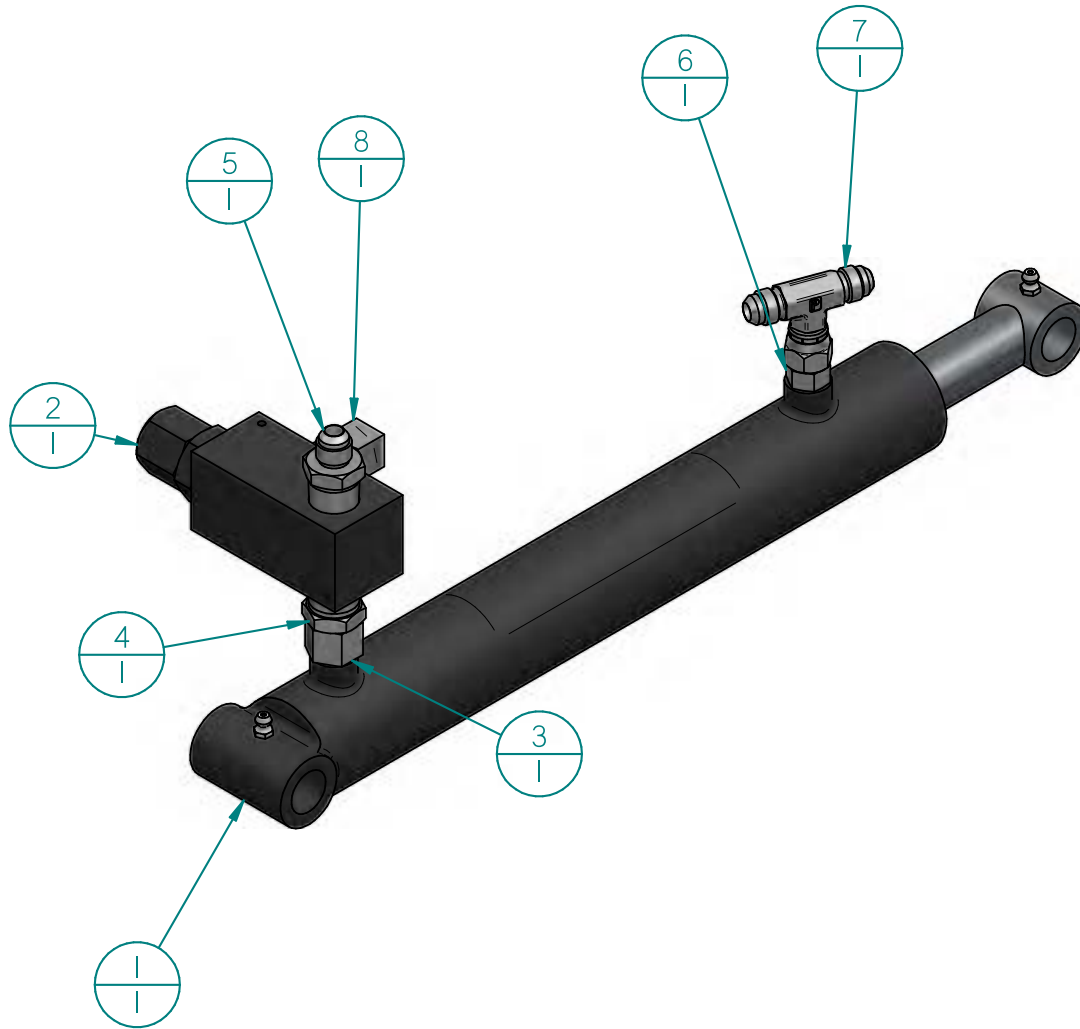

Item No	Part No	Part Name	Qty
1	50000-30021	Magister 1,5" x 8" Saw Cylinder	1
2	50000-10014	RD 1850 Pressure Relief	1
3	856-101	#4 ORB M to #6 ORB F Reduser	1
4	835-121	#8 NPT M to #6 ORB M	1
5	813-112	#6 JIC M to #8 NPT M	1
6	815-110	#6 JIC M to #4 ORB M	1
7	800-091	#6 TEE JIC M xJIC F Swi xJIC M	1
8	813-212	#6 JIC M to #8 M NPT 90	1



**PROCESSOR SAW CYLINDER CLEVIS**

Item No	Part No	Part Name	Qty
1	262-068	Pro HD Saw Cyl Clevis 5-9-22	1
2	9000-0169	Pin .75D 2.75UL for Cotter Pins	1
3	40000-10002	Zn Cotter Pin 3/16" x 1-1/2" L	2
4	.375 Washer	W3/8	8
5	.375x16 1.5 Blot	HH3/8X1.5	4
6	.375 Nut	N3/8	4

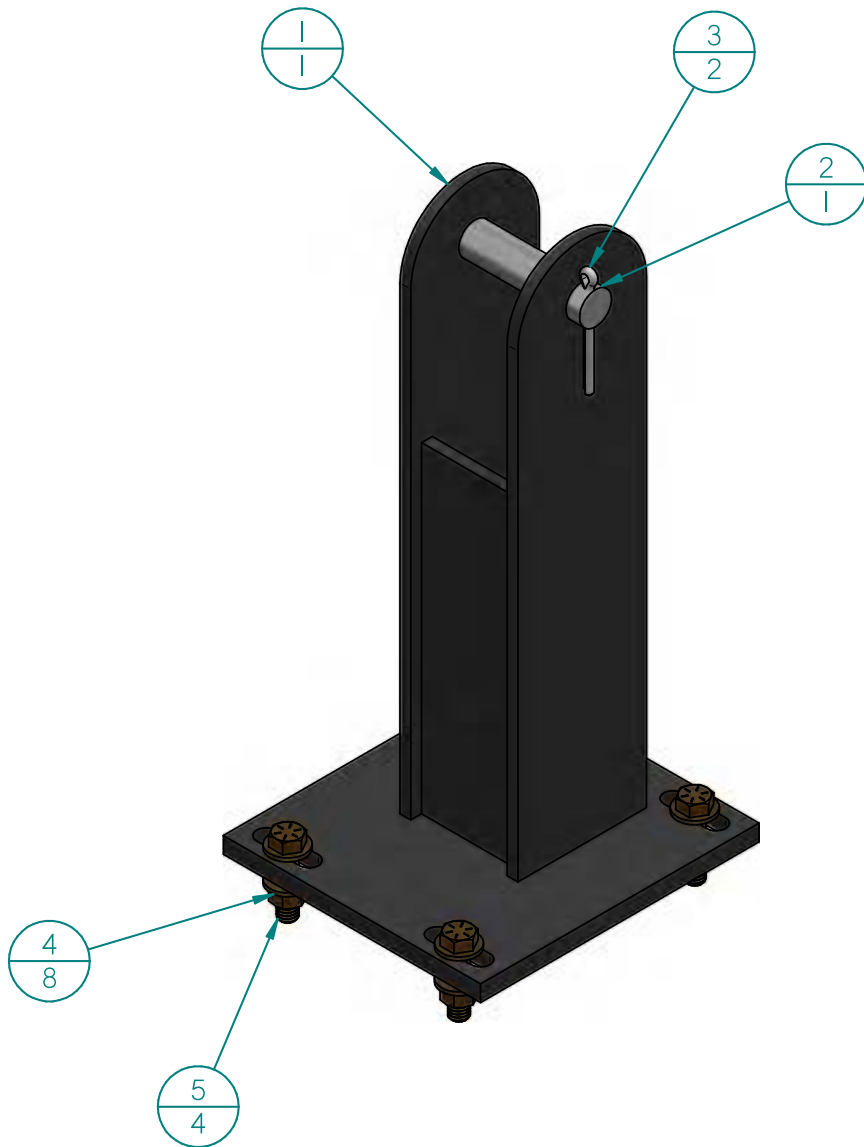

## PROCESSOR PUSH BLOCK

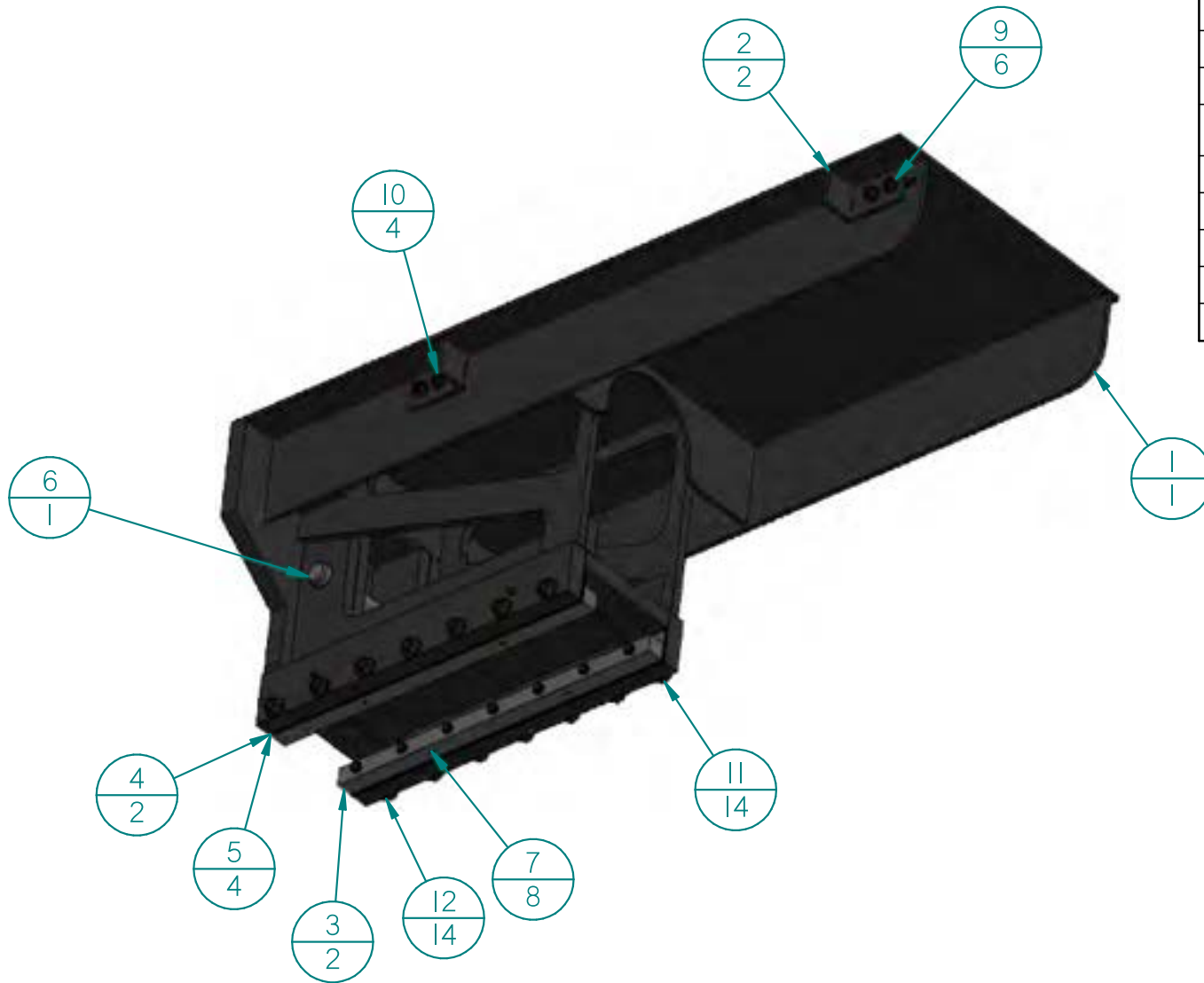

Item No	Part No	Part Name	Qty
1	9000-0240	Pro HD Push Block 9-27-23	1
2	9000-0262	Pro Limit Switch Slider 9-22-23	2
3	9000-0239	1x1x20,5 Wear Plate	2
4	9000-0238	1,875"x20,5"x125" Shim	2
5	9000-0245	1,875"x20,5"x0,625" Shim	4
6	9000-0246	Pin 1,25D 6,622UL	1
7	Grease Fitting 1/4	1/4 Grease Fitting	8
8	NN3/8	NN3/8	4
9	W3/8	W3/8	6
10	HH3/8x1,25	HH3/8x1,25	4
11	HH1/2x2,5	.5x13 2,5 Bolt	14
12	W1/2	W1/2	14

**PROCESSOR OIL COOLER**

Item No	Part No	Part Name	Qty
1	20000-30002	Oil Cooler	1
2	60000-10037	Cooler Temp Switch	1
3	815-144	#12 JIC M to #12 ORB M	1
4	815-244	#12 JIC M to #12 ORB M 90	1
5	.375 Washer	.375" Washer	8
6	.375x16 1.25	3/8"x16 1.25 Bolt	4
7	.375 Nut	3/8" Nut	4

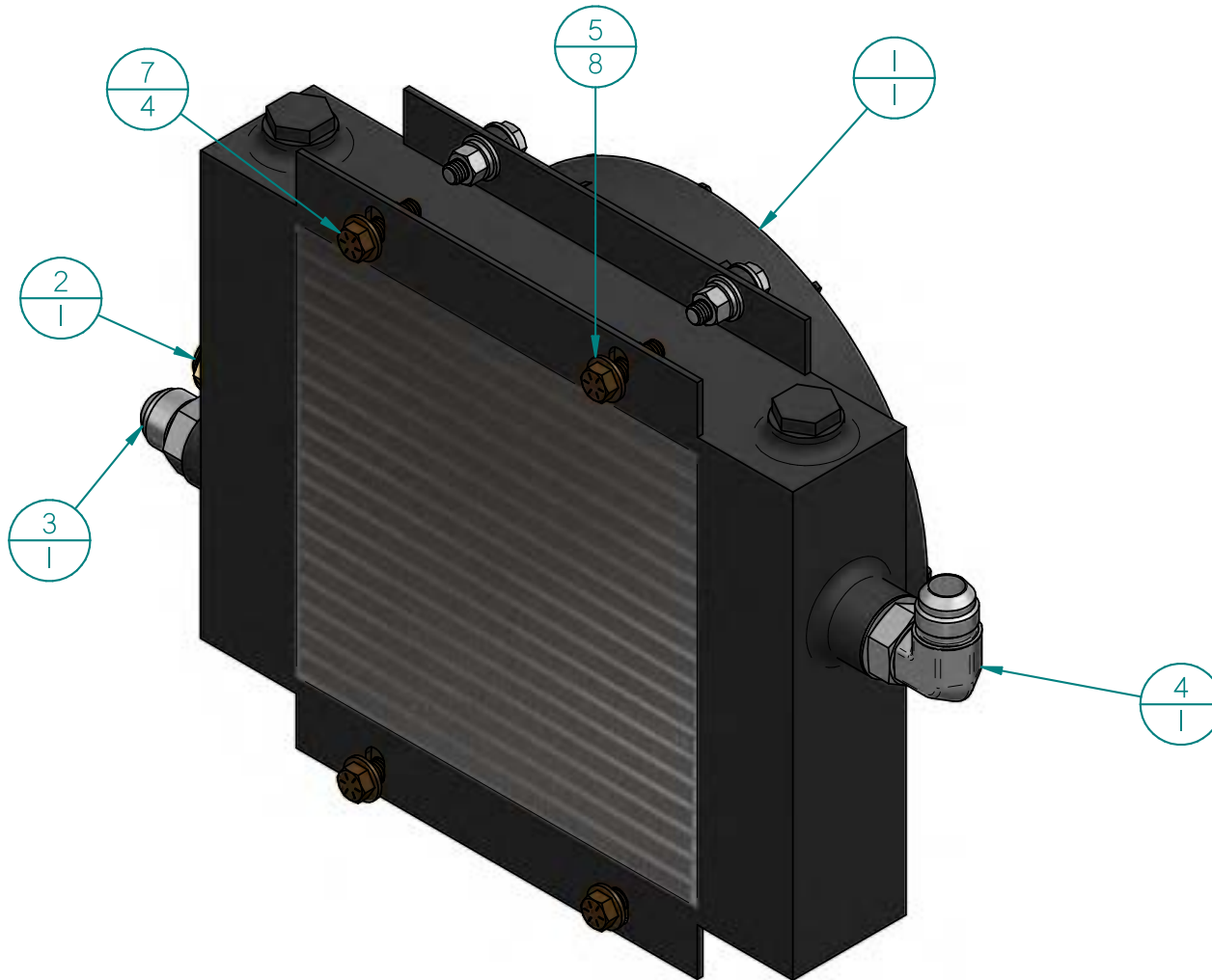

## PROCESSOR MANIFOLD

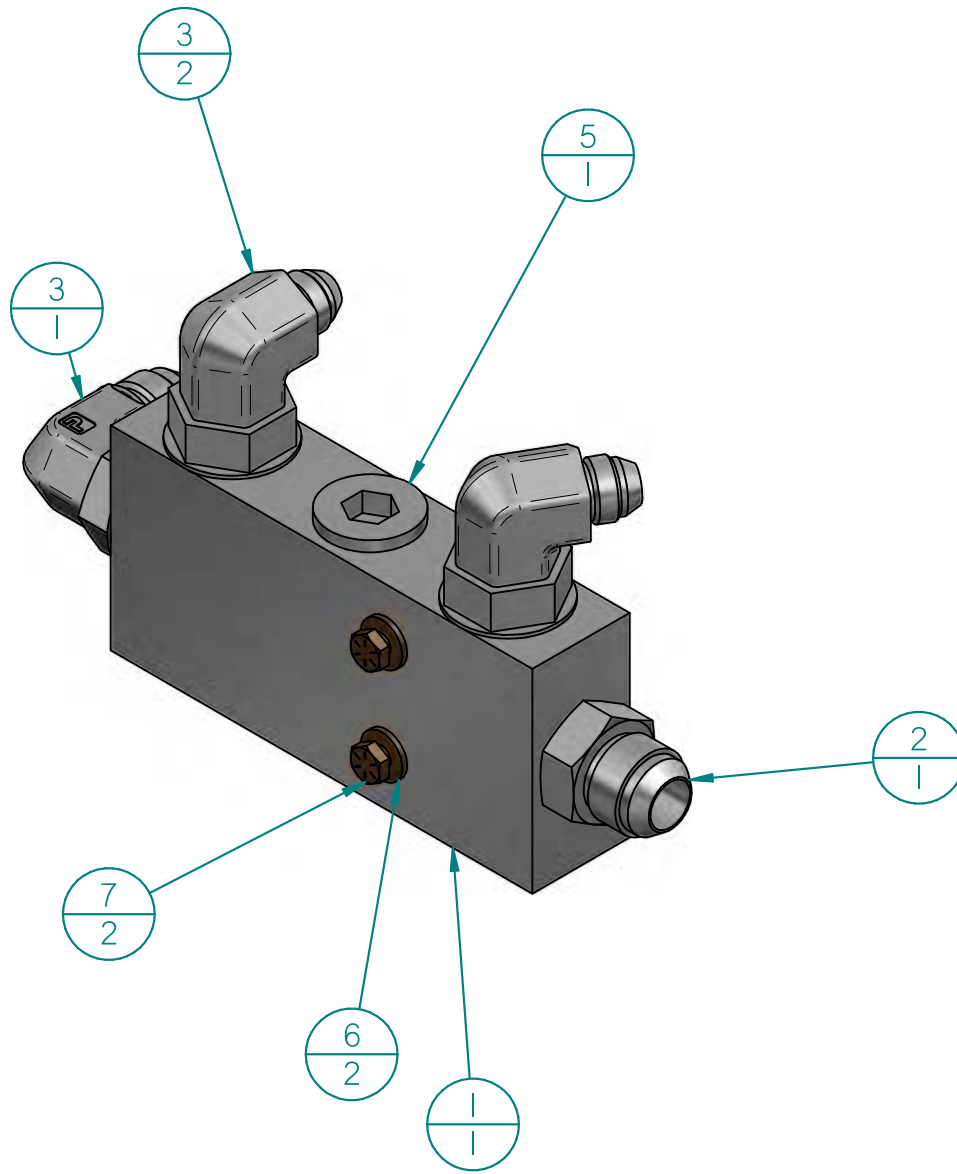

Item No	Part No	Part Name	Qty
1	902-000	Pro HD Manifold	1
2	815-144	#12 JIC M to #12 ORB M	1
3	815-224	#8 JIC M to 12 ORB M 90	2
4	815-244	#12 JIC M to #12 ORB M 90	1
5	800-167	#12 ORB Plug	1
6	.25 Washer	1/4" Flat Washer	2
7	.25x20 2.5 Bolt	.25x20 2.5 Bolt	2

**PRO-HD, HD X, HD XL MAIN FRAME**

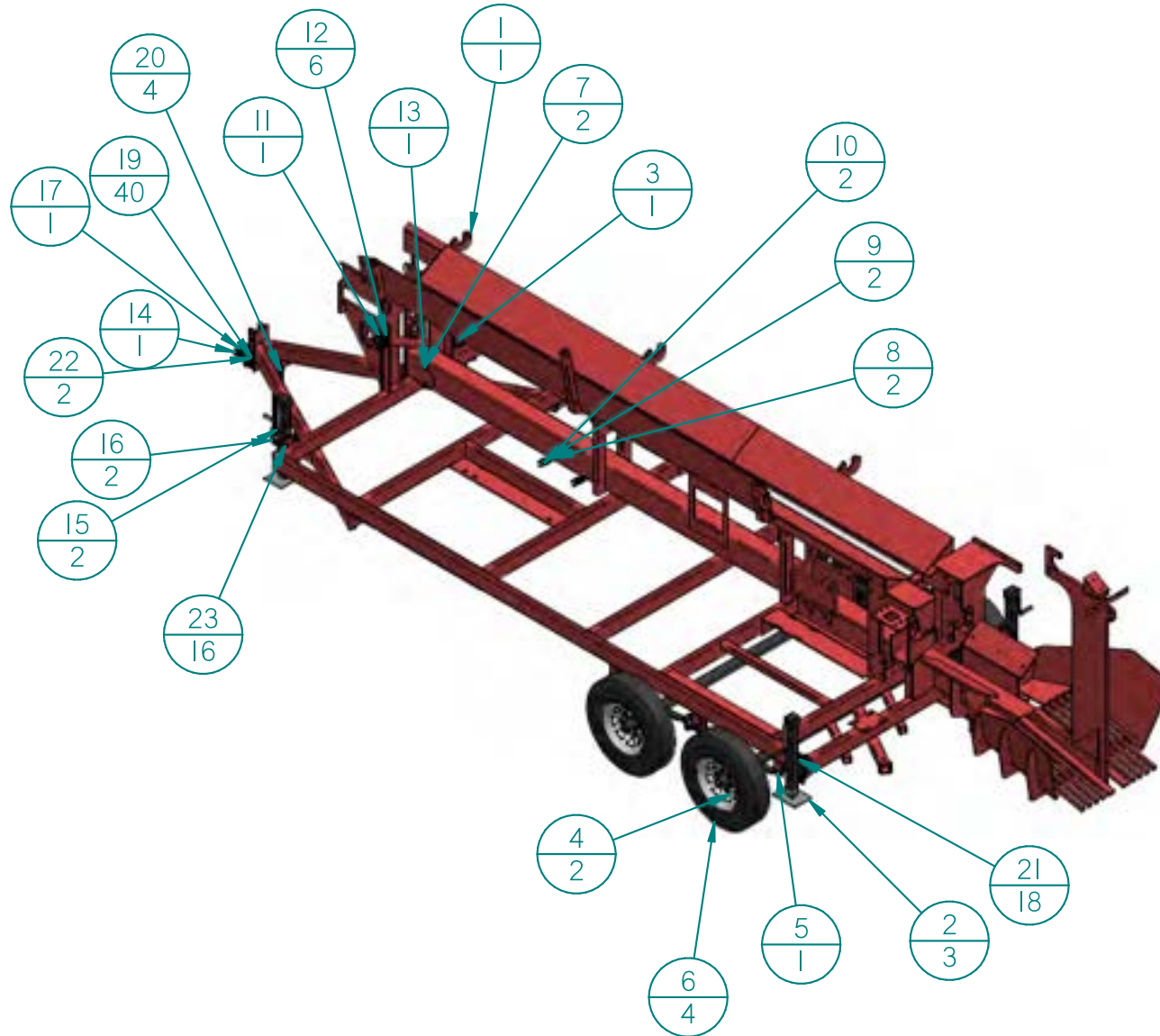

Item No	Part No	Part Name	Qty
1*	9000-0231	Pro HD Mainframe 9-12-23	1
2	9000-0047	Pro HD Jack 1	3
3	9000-0059	Pro HD Jack 2	1
4	9000-00012	Pro HD Axle	2
5	90000-00014	Hanger Bolts, Nuts, Connectors	1
6	90000-00011	6 Lug Wheel	4
7	873-200	#4 Hose Barb to #4 NPT M 90	2
8	833-100	#4 NPT M to #4 NPT M SS (included in 50000-30007)	2
9	50000-30007	1/4" SS Ball Valve	2
10	800-149	5/16" Barb to #4 NPT M SS	2
11	20000-10004	Breather Filler	1
12	SHCS10-32X1/2	SHCS10-32X1/2	6
13	10000-20001 x1.67	1/4" Clear Line	1
14	90000-00010	Processor Ball Coupler	1
15	90000-00009	Pro 5/16" Safety Chain	2
16	90000-00013	Pro 5/16" Safety Chain Hook	2
17	40000-10001	Coupler Snapper Pin 1/4" x 2"	1
18*	10000-20004	1/2" Thick x 3" W Plastic 5'	3
19	W1/2	W1/2	40
20	NN1/2	NN1/2	4
21	HH1/2X2,25	HH1/2X2,25	18
22	HH1/2x5	.5x13 5 Bolt	2
23	N1/2	N1/2	16

### PROCESSOR LOWER RIGHT VALVE

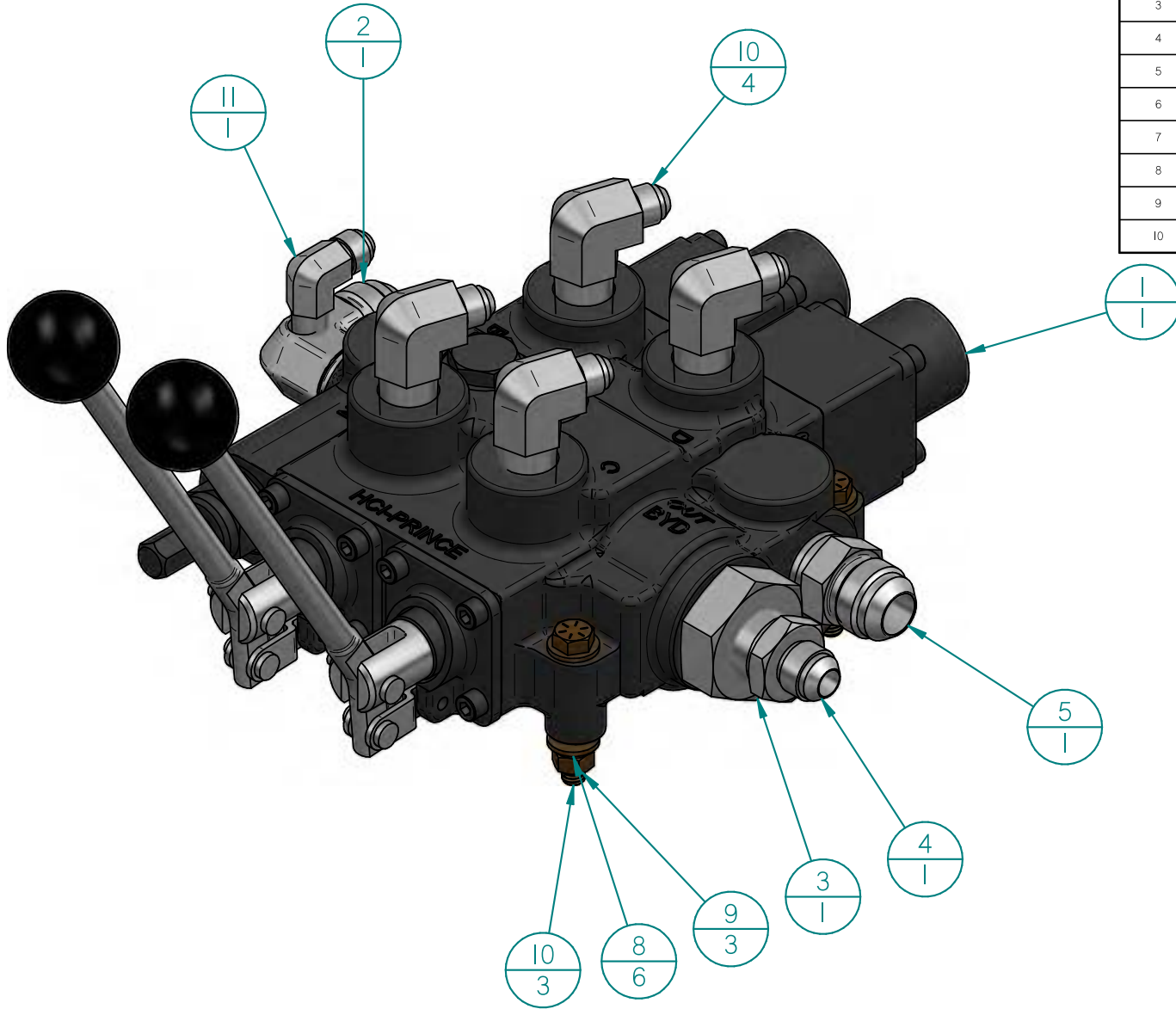

Item No	Part No	Part Name	Qty
1	50000-10002	2 Spool Flat Valve	1
2	813-244-D	#12 JIC M to #12 NPT M 90	1
3	800-041	Power Beyond Plug Kit	1
4	813-124	#8 JIC M to #12 NPT M	1
5	813-144	#12 JIC M to #12 NPT M	1
6	813-212	#6 JIC M to #8 M NPT 90	4
7	813-210	#6 JIC M to #4 NPT M 90	1
8	.3125 Washer	W5/16	6
9	.3125 Nut	N5/16	3
10	.3125x18 2.25 Bolt	5/16"x18 2.25 Bolt	3

**PROCESSOR LOWER LEFT VALVE**

Item No	Part No	Part Name	Qty
I	50000-10001	3 Spool Valve RD532CCCAA5A4BI	1
2	9000-0003	Saw Switch Mount	1
3	60000-10038	Bar Oil Switch	1
4	813-244-D	#12 JIC M to #12 NPT M 90	1
5	813-244	#12 JIC M to #12 NPT M 90	1
6	813-212	#6 JIC M to #8 M NPT 90	2
7	813-222	#8 JIC M to #8 NPT M 90	2
8	813-232	#10 JIC M to #8 NPT M 90	1
9	813-210	#6 JIC M to #4 NPT M 90	1
10	.3125 Washer	5/16" Washer	6
11	.3125 Nut	5/16" Nut	3
12	.3125x18 2.25 Bolt	5/16"x18 2.25 Bolt	3

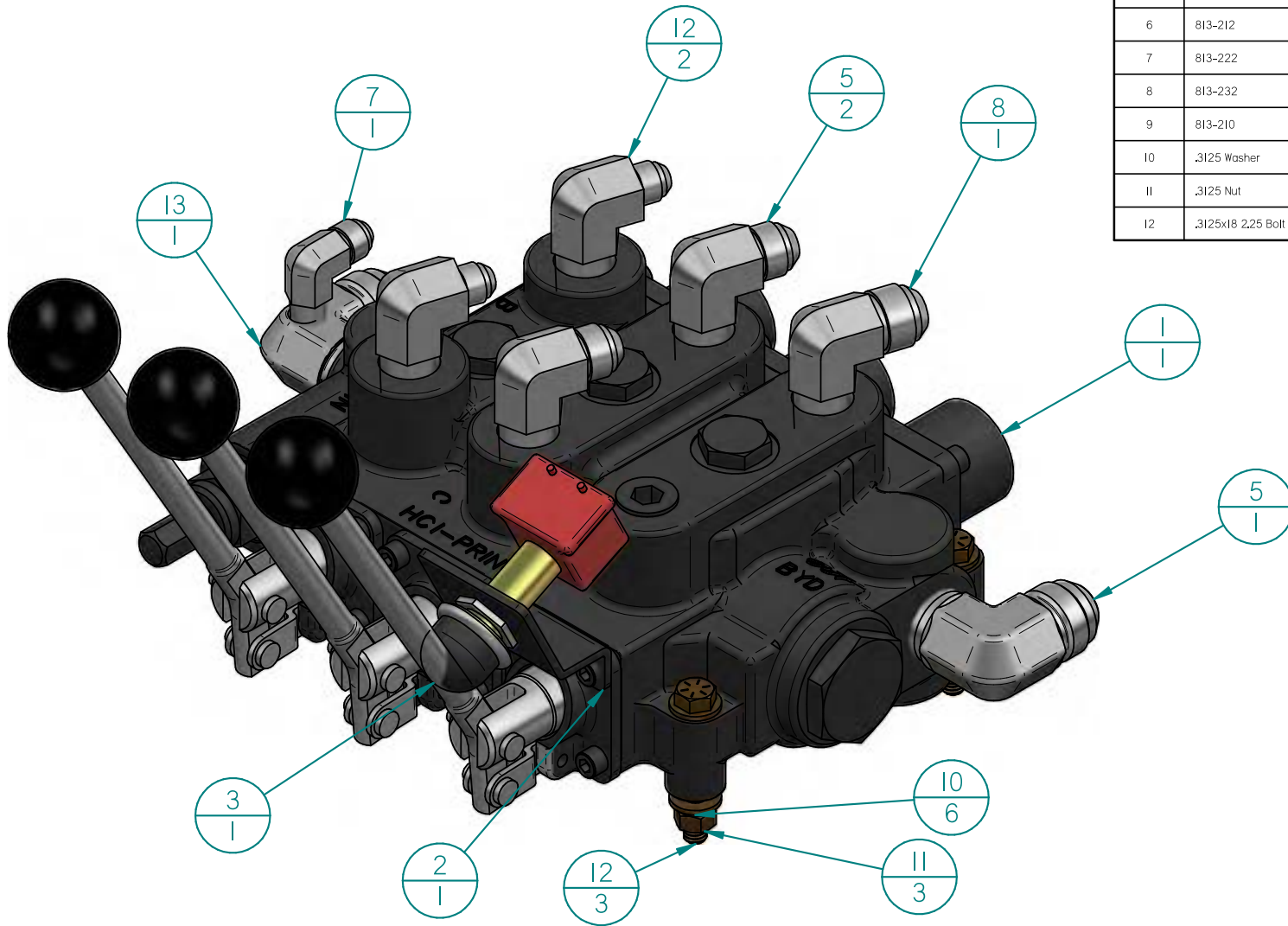



## PROCESSOR LOG FLIPPER

Item No	Part No	Part Name	Qty
1	9000-0018	Pro Log Flipper	2
2	.375 Washer	.375" Washer	8
3	.375x16 1,5 Blot	3/8"x16 1,5 Blot	4
4	.375 Lock Nut	.375 Lock Nut	4

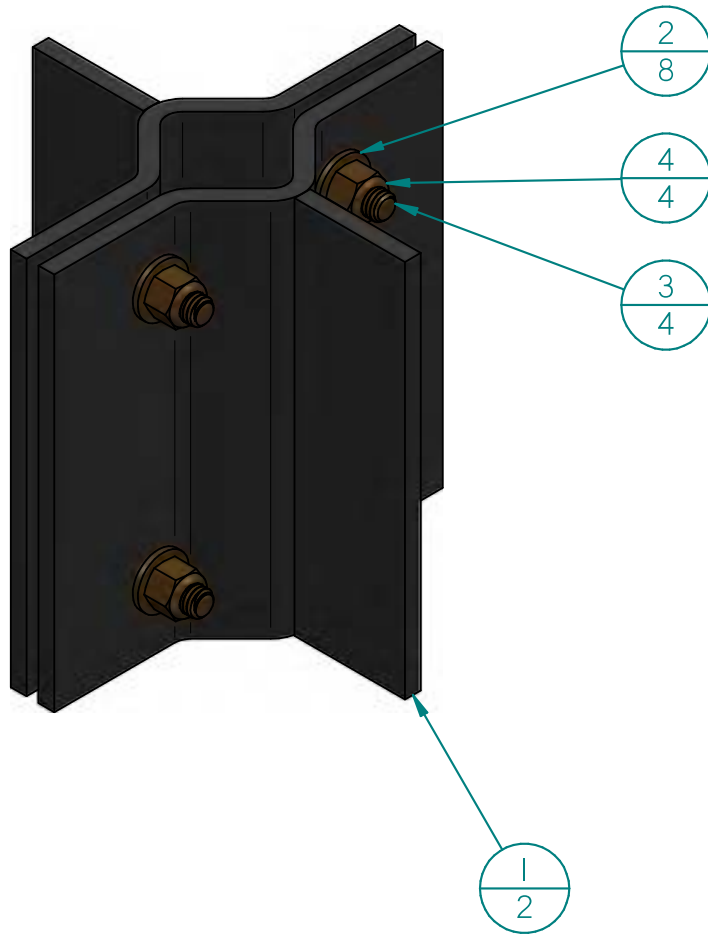

**PROCESSOR LIVE DECK TENSION BLOCK**

Item No	Part No	Part Name	Qty
1	9000-0015	Pro LD Motor Adjuster	2
2	.5 Washer	1/2" Washer	2
3	.5x13 3,5 Bolt	.5x13 3,5 Bolt	2
4	9000-0002	Pro TR Tensioner Rod	2
5	.5 Nut	1/2" Nut	6

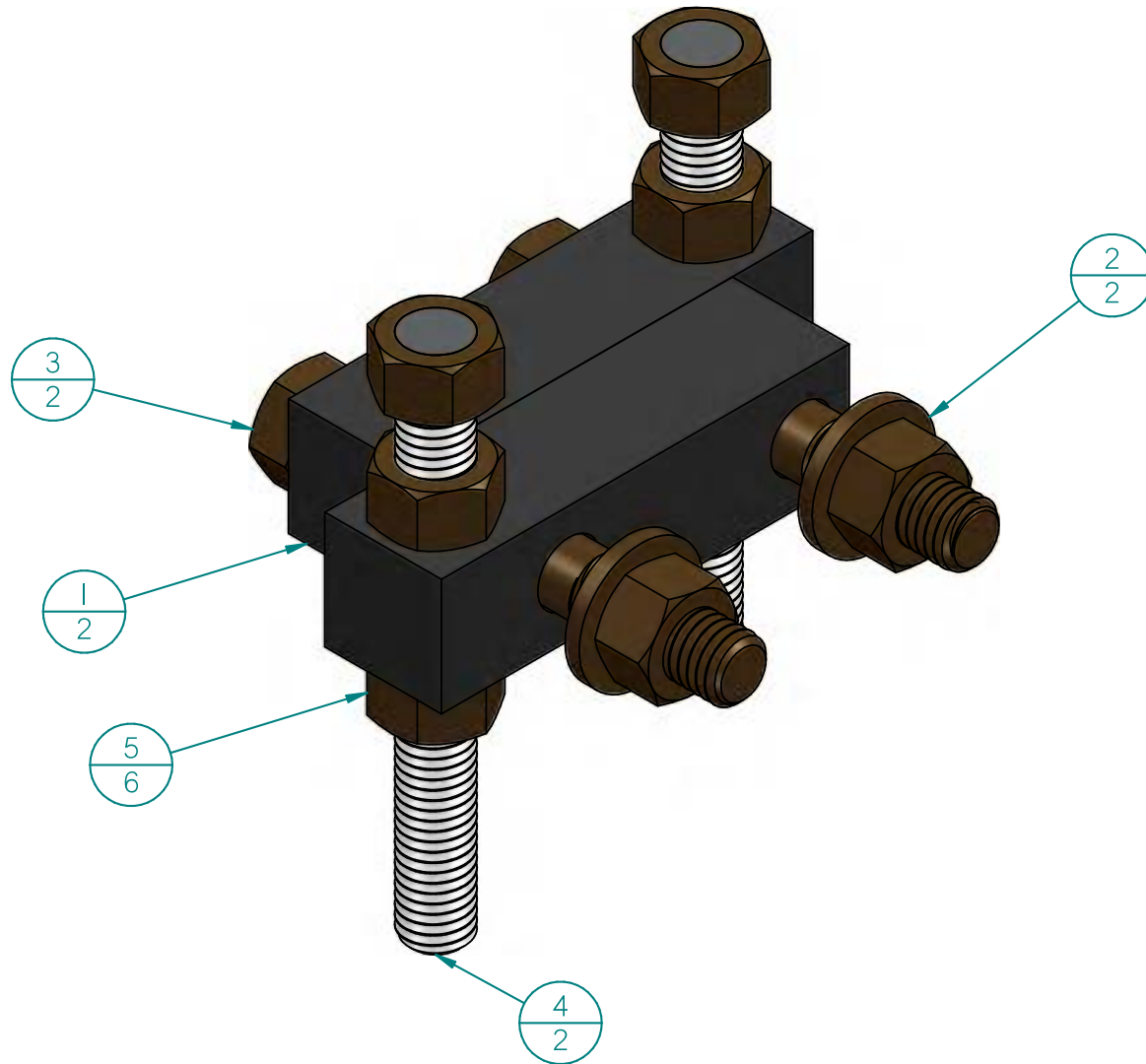

## PROCESSOR LIVE DECK MOTOR 315

Check Motor Ports -  
if #8 NPT, use 813-212 x2  
if #10 ORB, use 815-213 x2

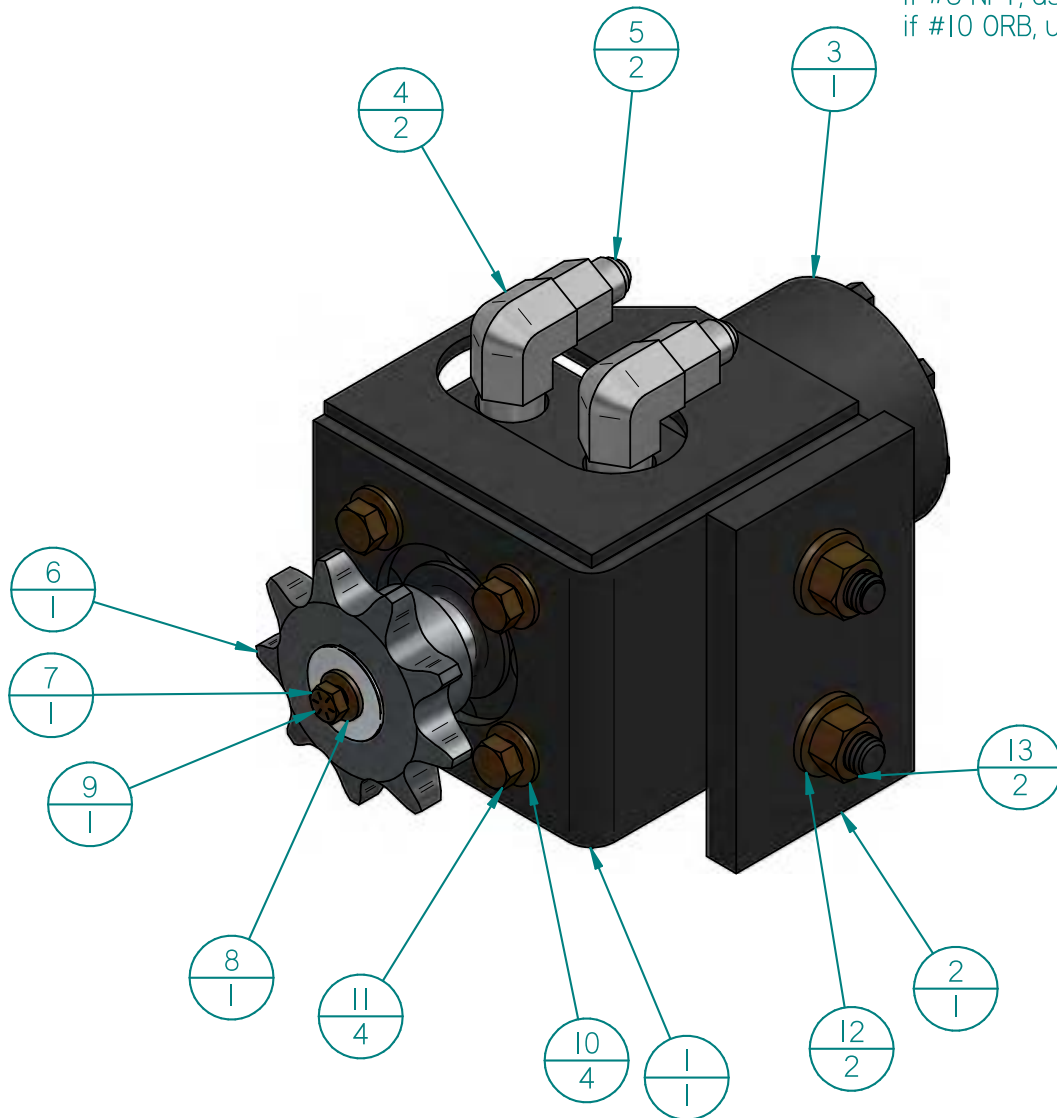

Item No	Part No	Part Name	Qty
1	9000-0130	Pro Top Roll Motor Mnt	1
2	9000-0027	PRO TR Motor Adjuster Plate	1
3	50000-20009	Pro TR FT Motor	1
4	813-212	#6 JIC M to #8 M NPT 90	2
5	800-120	.078 Orifice #6 JIC to #6 JIC	2
6	9000-0166	Pro Live Deck Sprocket for 315 Motor	1
7	FW1/4	.25" Flange Washer	1
8	W1/4	W1/4	1
9	HH1/4x75	HH1/4X3/4	1
10	W3/8	W3/8	4
11	HH3/8x1	HH3/8X1	4
12	W1/2	.5 Washer	2
13	N1/2	N1/2	2

**PROCESSOR 3 STRAND LIVE DECK**

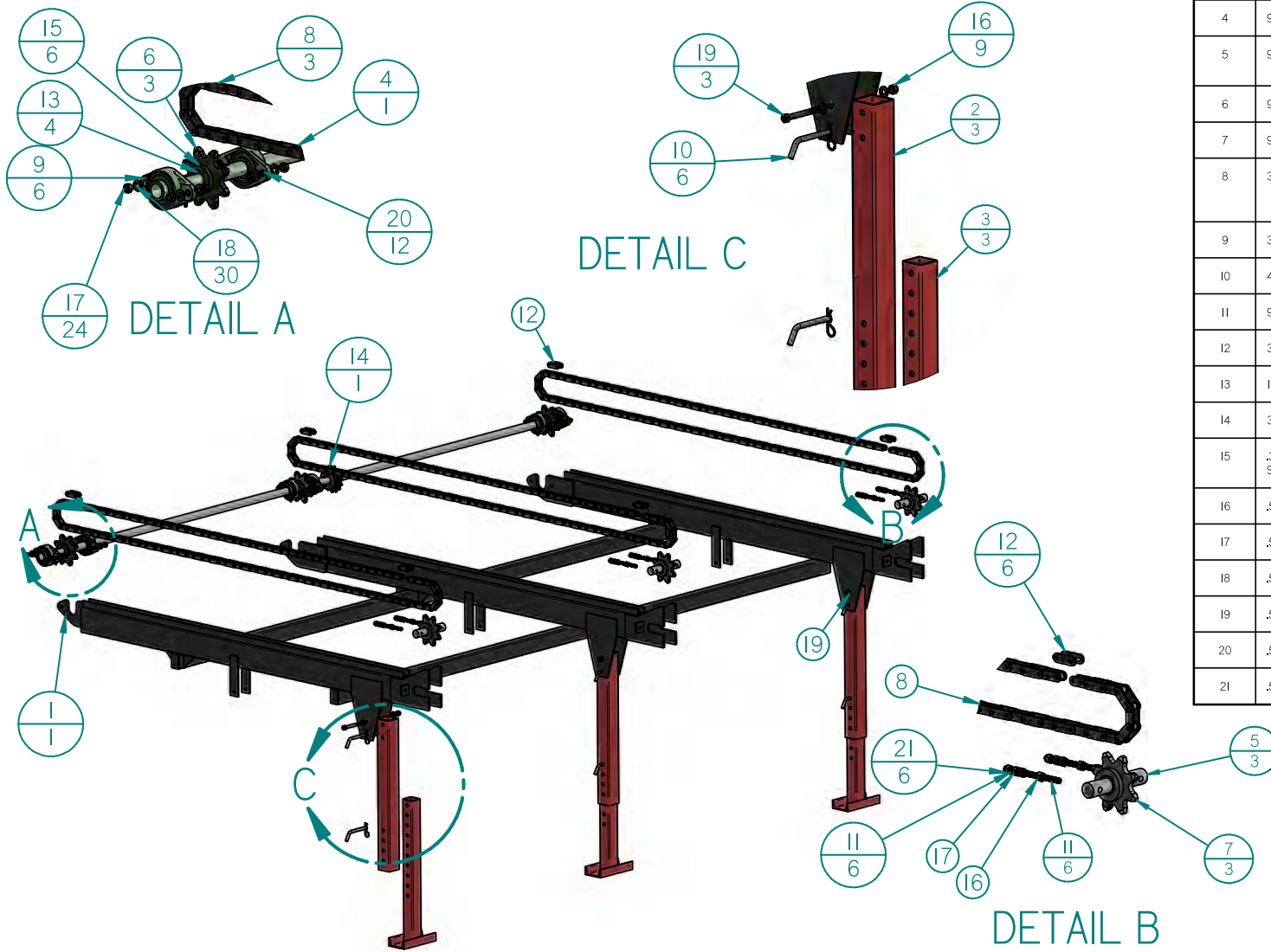

Item No	Part No	Part Name	Qty
1	9000-0073	Pro Live Deck 3 Strand	1
2	9000-0045	Pro LD Outer Leg	3
3	9000-0044	Pro Live Deck Inner Leg	3
4	9000-0080	Pro HD 3 Strand Shaft 1.5x146	1
5	9000-0041	PRO Live Deck Idler Shaft 1.5 x 7.625	3
6	9000-0149	Live Chain Drive Sprocket 1.5	3
7	9000-0150	Live Chain Idler Sprocket 1.5	3
8	30000-30013	C2082 Chain, use 5,13 units for 3 strand, 8,7 units for 5 strand	3
9	30000-30002	2 Bolt 1-1/2 Flange Bearing	6
10	40000-10006	Pull Pin 1/2" x 4" Usable	6
11	9000-0036	Pro Live Deck Tensioner Bolt	6
12	30000-20006	2082 Master Link	6
13	10000-11014	3/8"x1.25" Key	4
14	30000-20001	15 Teeth #80 Sprocket 1.5"	1
15	.375x16-5 Set Screw	.375x16-5 Set Screw	6
16	.5 Lock Nut	.5 Lock Nut	9
17	.5 Nut	NI/2	24
18	.5 Washer	.5 Washer	30
19	.5x13 4.5 Bolt	.5x13 4.5 Bolt	3
20	.5x13 2.25 Bolt	HH1/2X2,25	12
21	.5 anchor nut	1/2" Anchor Nut	6

## PROCESSOR 5 STRAND LIVE DECK

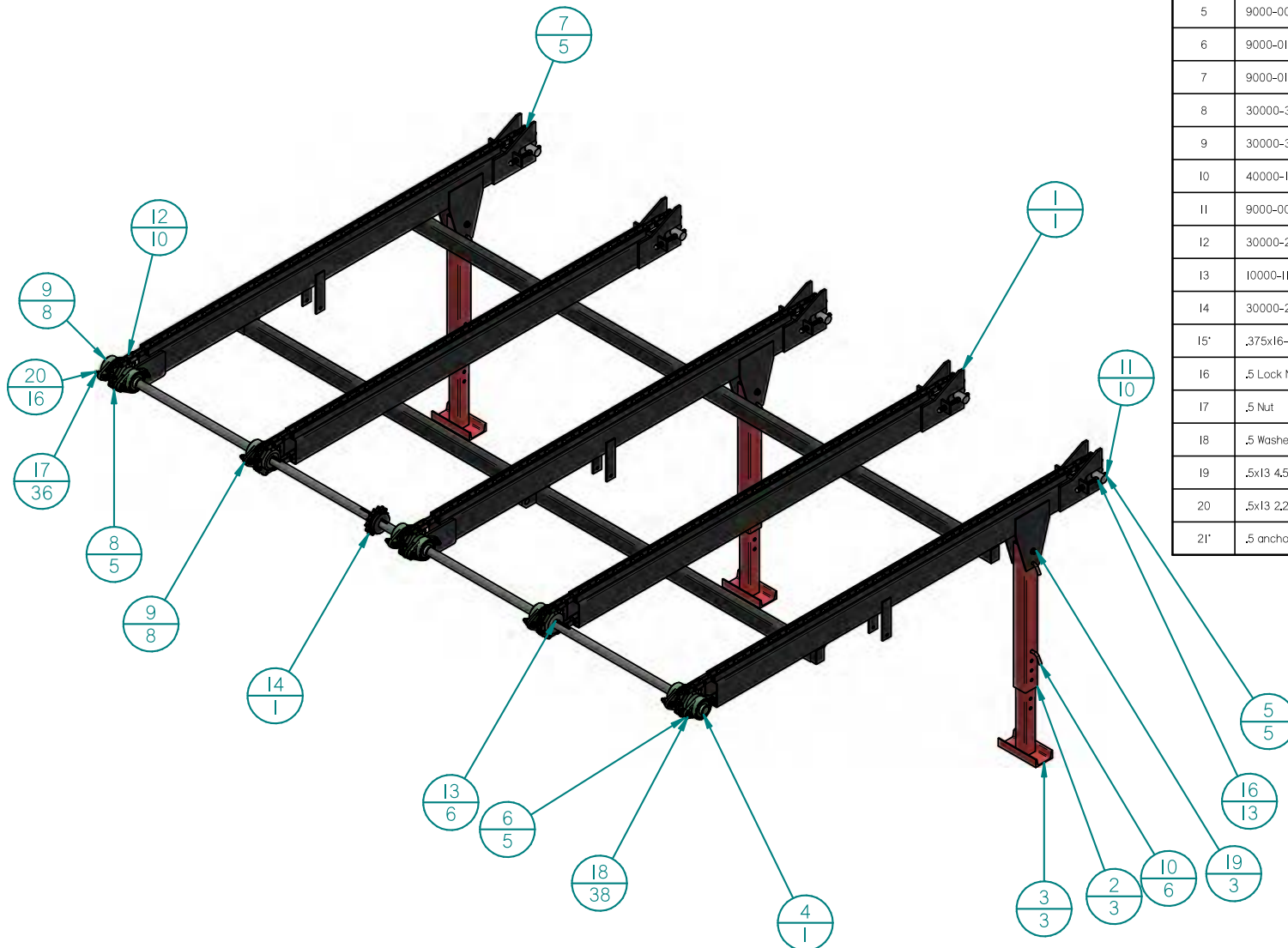

Item No	Part No	Part Name	Qty
1	252-747	PRO Live Deck 5 Stand	1
2	9000-0045	Pro LD Outer Leg	3
3	9000-0044	Pro Live Deck Inner Leg	3
4	9000-0143	Pro HD 5 Stand Shaft	1
5	9000-0041	PRO Live Deck Idler Shaft 1.5 x 7.625	5
6	9000-0149	Live Chain Drive Sprocket 1.5	5
7	9000-0150	Live Chain Idler Sprocket 1.5	5
8	30000-30013	C2082 Chain	5
9	30000-30002	2 Bolt 1-1/2 Flange Bearing	8
10	40000-10006	Pull Pin 1/2" x 4" Usable	6
11	9000-0036	Pro Live Deck Tensioner Bolt	10
12	30000-20006	2082 Master Link	10
13	10000-11014	3/8"XL.25" Key	6
14	30000-20001	15 Teeth #80 Sprocket 1.5"	1
15*	.375x16-.5 Set	.375x16-.5 Set Screw	9
16	.5 Lock Nut	NNI/2	13
17	.5 Nut	NI/2	36
18	.5 Washer	WI/2	38
19	.5x13 4.5 Bolt	.5x13 4.5 Bolt	3
20	.5x13 2.25 Bolt	HHI/2X2.25	16
21*	.5 anchor nut	1/2" Anchor Nut	10

**PROCESSOR LIVE DECK CYLINDER**

Item No	Part No	Part Name	Qty
1	256-008	2"x24" Cylinder #8 Ports	1
2	815-212	#6 JIC M to #8 ORB M 90	2



## PROCESSOR HYDRAULIC TANK

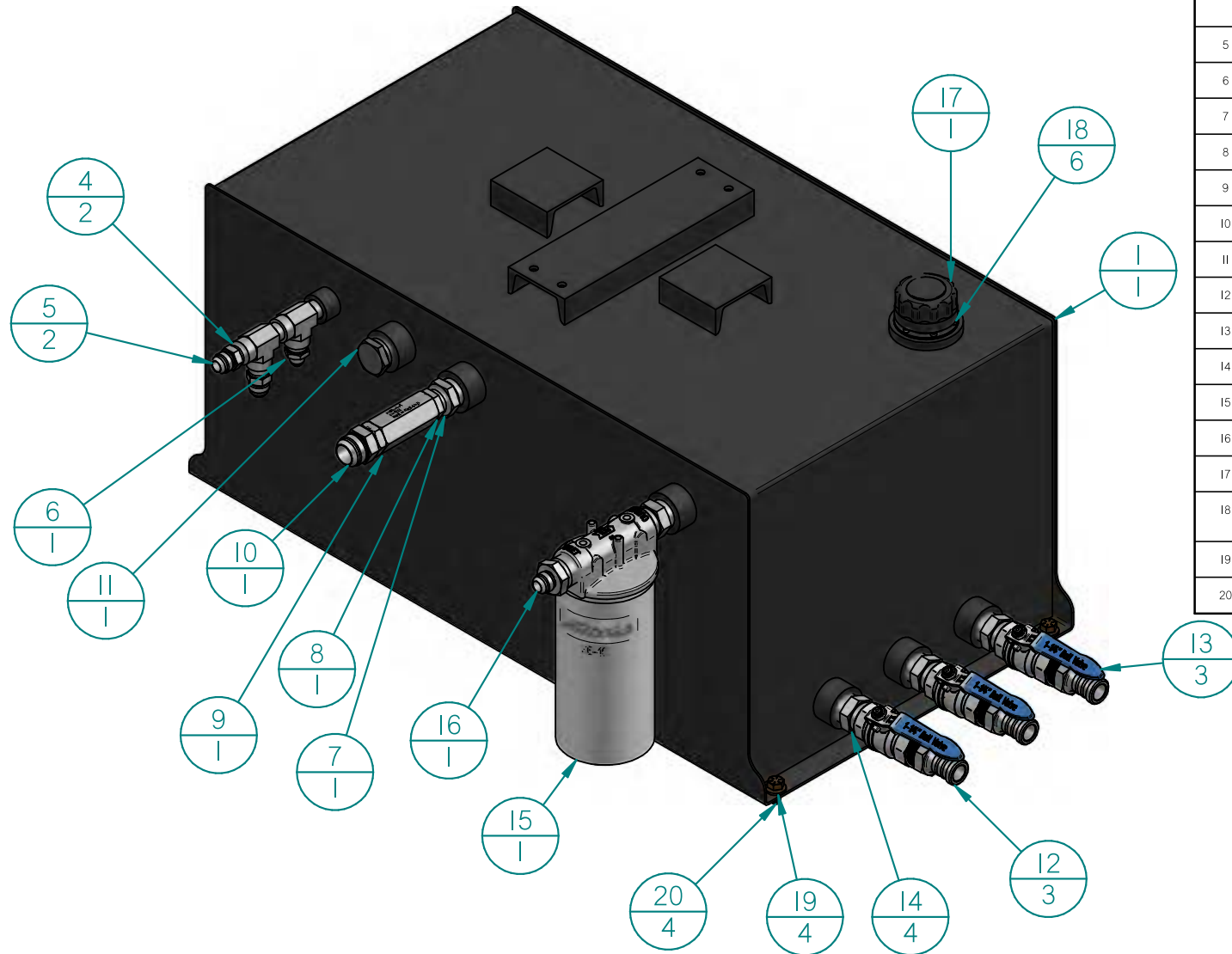

Item No	Part No	Part Name	Qty
1	252-545	Pro HD Hyd Tank	1
2	20000-20027	Sight Level Gauge	1
3	9001-0212	Magnet Plug	1
4	800-059	#12 Male Run Tee (NPTMxNPTFxNPTF)	2
5	813-144	#12 JIC M to #12 NPT M	2
6	813-124	#8 JIC M to #12 NPT M	1
7	834-165	#16 NPT F to #20 NPT M	1
8	835-155	#16 NPT M to #16 ORB M	1
9	50000-10019	Pro Inline Check Valve	1
10	815-165	#20 JIC M to #16 ORB M	1
11	800-053	1 1/4 Plug #20 NPT	1
12	873-166	#20 Barb to #20 NPT M	3
13	50000-30006	Ball Valve 1.25F to 1.25F NPT	3
14	833-166	#20 NPT M to #20 NPT M	4
15	20000-20029	70 GPM Filter Long	1
16	813-146	#12 JIC M to #20 NPT M	1
17	20000-10004	Breather Filler	1
18	10-32 x 0.5 Socked Head	SHCI0-32X1/2 (Comes with breather filler 5-II-231)	6
19	.5 Washer	W1/2	4
20	.5x13 I Bolt	HH1/2X1	4



**PROCESSOR FEED TROUGH SPROCKET COVER**

Item No	Part No	Part Name	Qty
1	9000-0029	Pro HD FT Sprocket Cover	1
2	.25 Washer	1/4" Flat Washer	4
3	.25x20 L25 Bolt	1/4"X1-1/4" Bolt	4

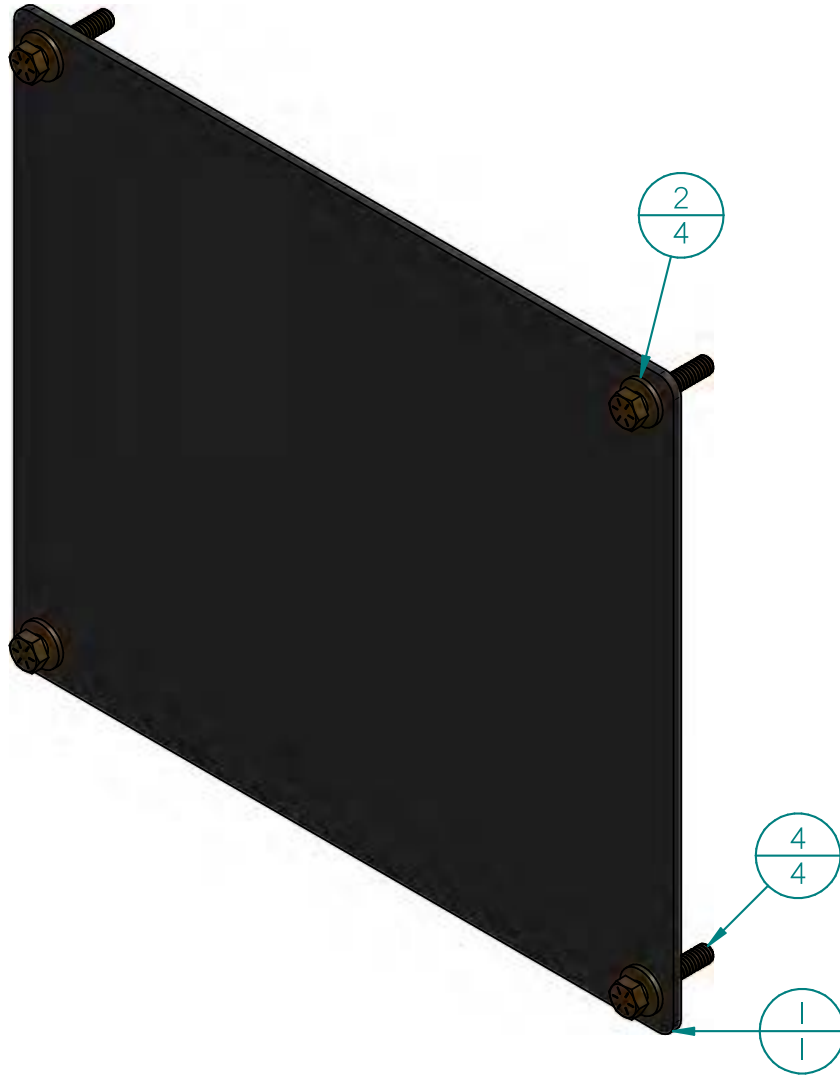

**PROCESSOR FEED TROUGH 50 CHAIN**



Item No	Part No	Part Name	Qty
1	30000-10002	#50 Chain, use .75 units per top level	1
2	30000-10011	#50 Chain Half Link	1
3	30000-10010	#50 Master Link	1

**PROCESSOR FRONT SPROCKET**

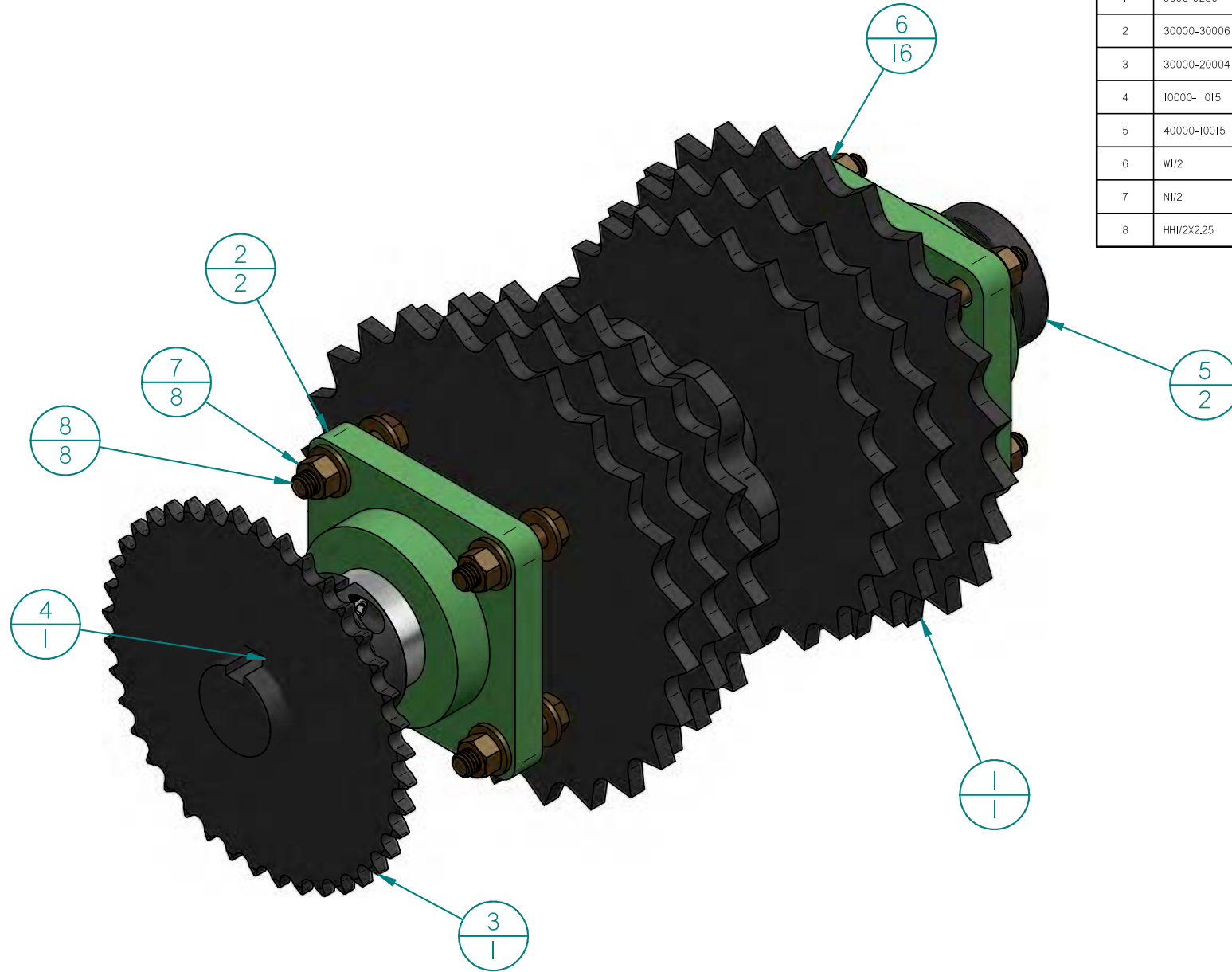

Item No	Part No	Part Name	Qty
1	9000-0230	Pro Front Wheel 9-5-23	1
2	30000-30006	4 Bolt Flange UCF210-31	2
3	30000-20004	40 Teeth #50 Sprocket 1-15/16	1
4	10000-11015	1/2"x1.5" Key	1
5	40000-10015	1-15/16 Shaft Collar	2
6	W1/2	.5 Washer	16
7	N1/2	N1/2	8
8	HH1/2X2,25	HH1/2X2,25	8

### PROCESSOR FLOW DIVIDER

Item No	Part No	Part Name	Qty
1	50000-10015	RD 575	1
2	813-144	#12 JIC M to #12 NPT M	1
3	813-224	#6 JIC M to #12 NPT M 90	1
4	813-244	#12 JIC M to #12 NPT M 90	1
5	.25 Washer	W1/4	2
6	.25x20 2.5 Bolt	.25x20 2.5 Bolt	2

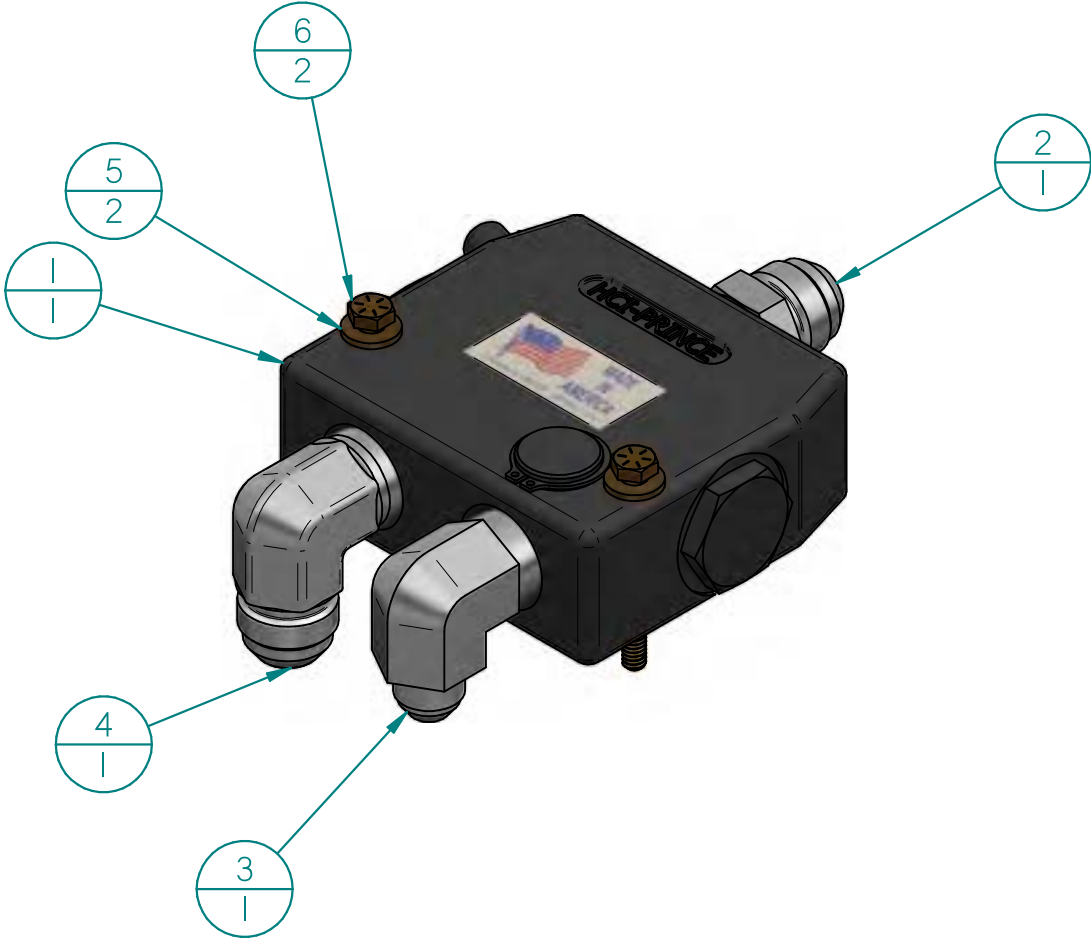

**PROCESSOR FENDER**

Item No	Part No	Part Name	Qty
1	9000-0108	Pro HD Fender 09 21	1
2	.5 Washer	1/2" Washer	5
3	.5x13 1/25 Bolt	.5x13 1/25 Bolt	5

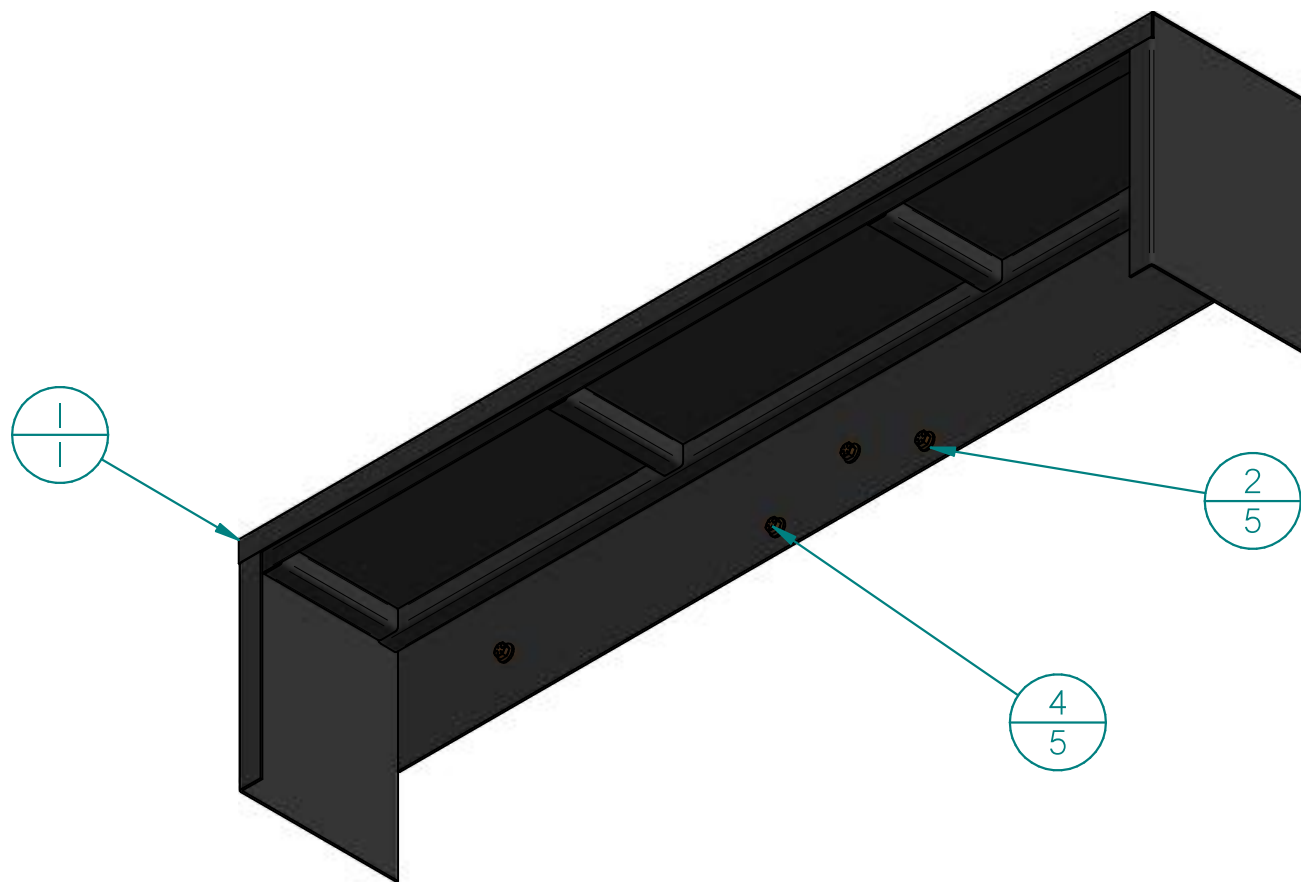

## PROCESSOR ENGINE COVER

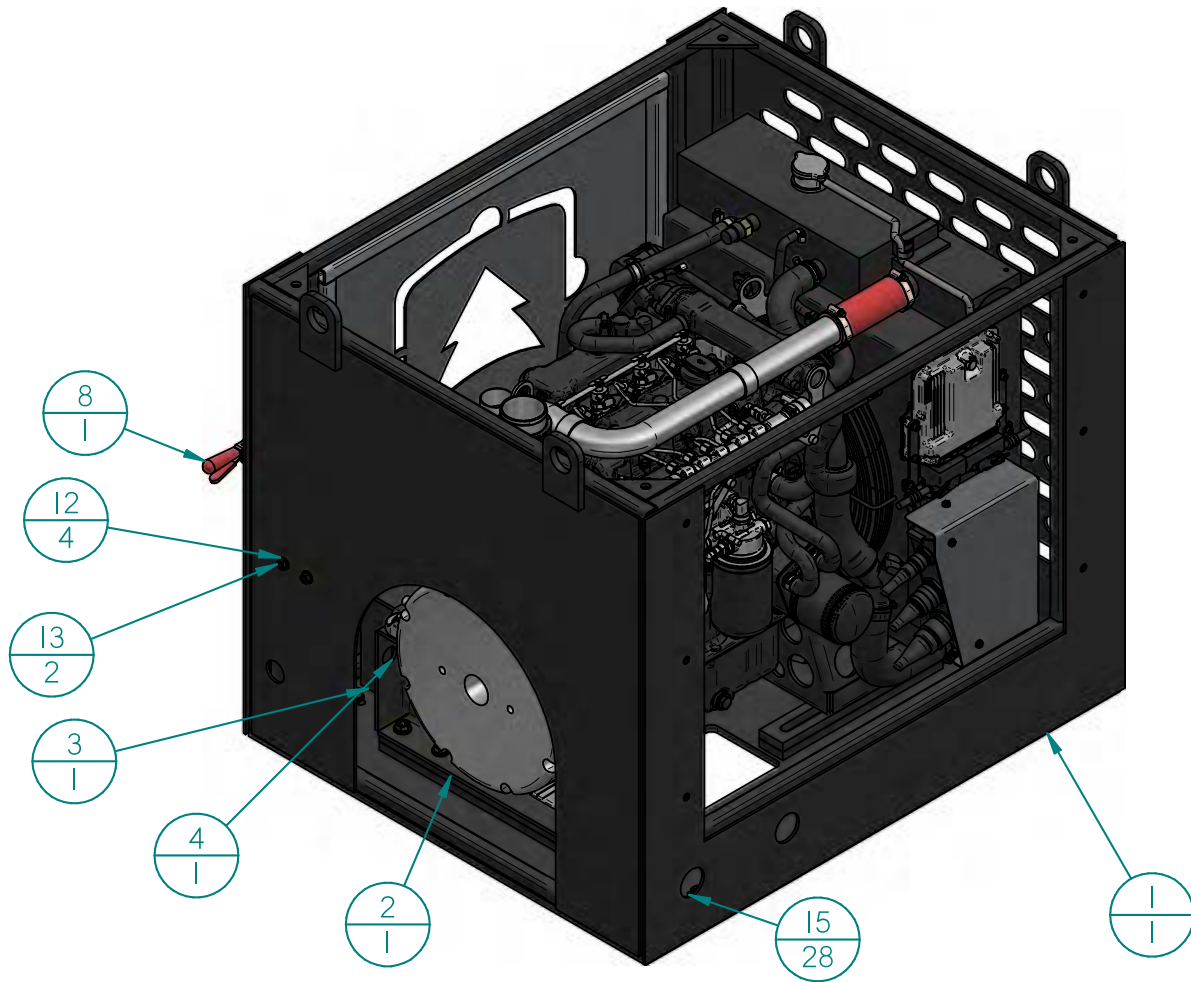

Item No	Part No	Part Name	Qty
1	9000-0050	Pro Engine Cover	1
2	70000-00006	Four cyl model- we only use 3 cyl	1
3	60000-10000	Processor Battery	1
4	9000-0039	Pro Battery Hold On	1
5*		Haz Engine fuel filter	1
6*	60000-10033	5/16" Battery Terminal	1
7*	60000-10034	3/8" Battery Terminal	1
8	10000-20005	Toggle Clamp Latch	1
9*		.25 Washer	W1/4
10*		.25 Lock Nut	.25 Lock Nut
11*		.25 self tap screw	1/4 Self tap screw
12		.375 Washer	W3/8
13		.375x16 1,75 Blot	.375 - 16 - 1,75 BOLT
14*		.375 Nut	N3/8
15		.5 Washer	W1/2
16*		.5x13 3,5 Bolt	HH1/2X3,5
17*		.5x13 2,5 Bolt	.5x13 2,5 Bolt
18*		.5 Nut	N1/2

**PROCESSOR ENGINE COVER TOP**

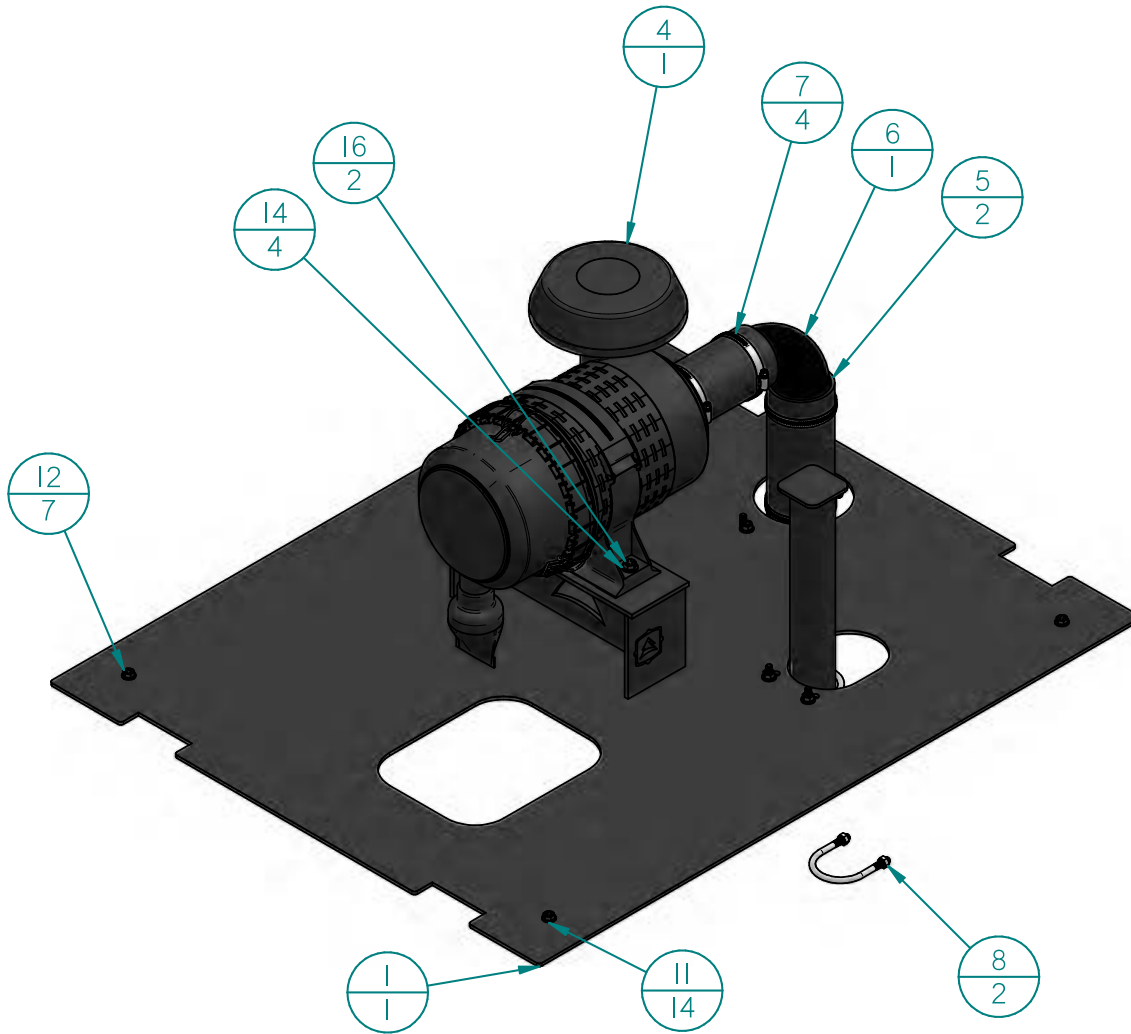

Item No	Part No	Part Name	Qty
1	9000-0049	Pro HD Engine	1
2*	9000-0004	Pro Exhaust	1
3*	9000-0033	Pro Dip Stick	1
4	Hatz air filter		1
5	70000-00014	3' Intank Hose	0.333
6	70000-00015	90 Intake Elbow	1
7	70000-00018	3" Worm Clamp	4
8	70000-00016	2-1/4" Exhaust	2
9*	9000-0009	2.25 Exhaust Pipe	1
10*	258-735	Flapper for	1
11	.3125 Washer	W5/16	14
12	.3125x18 L25 Bolt	5/16"x18 L25 Bolt	7
13*	.3125 Nut	N5/16	7
14	.375 Washer	W3/8	4
15*	.375 Lock Nut	NN3/8	2
16	.375x16 2 Blot	HH3/8X2	2



### PRO-HD, HD X, HD XL CONTROL PANEL

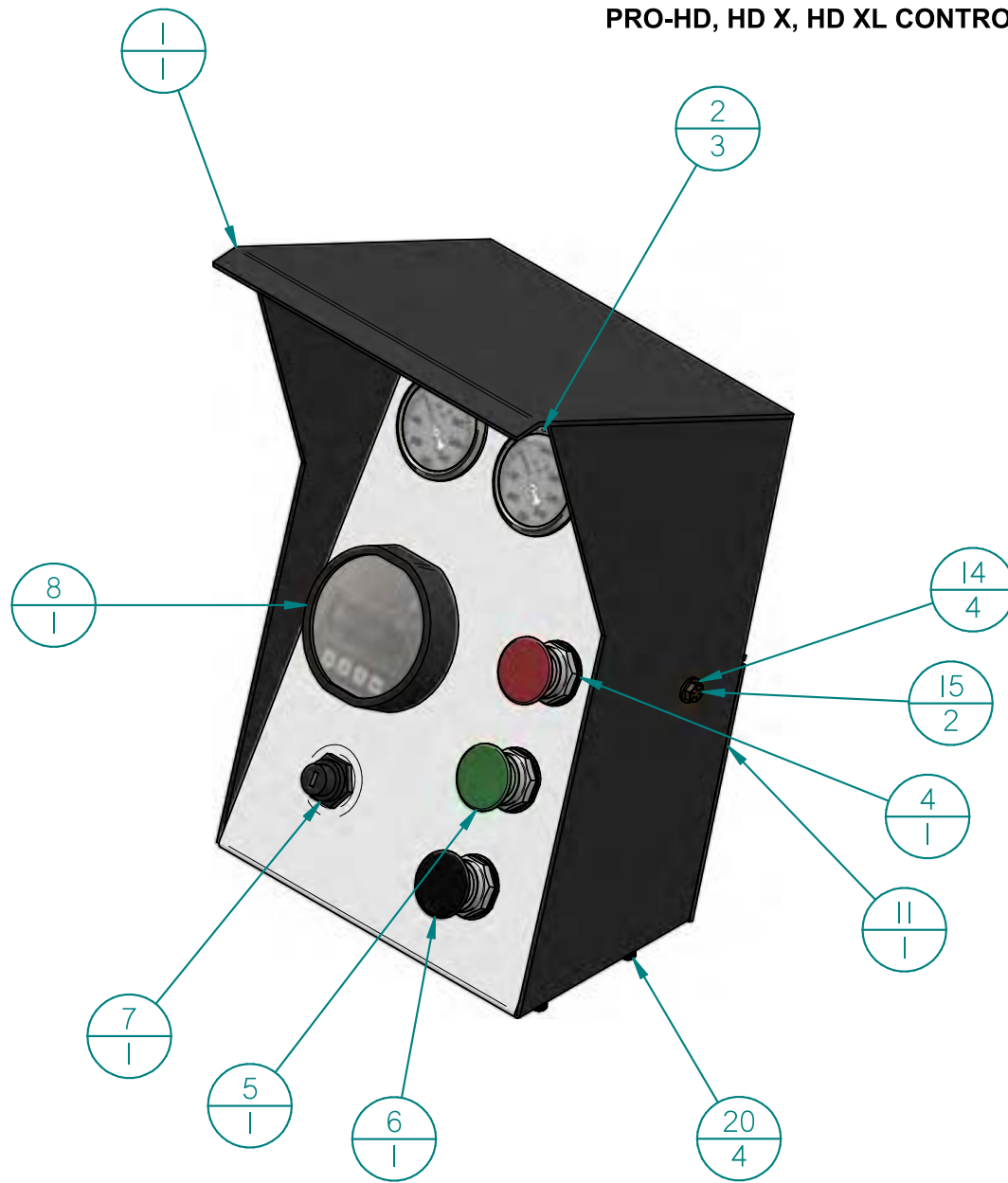

Item No	Part No	Part Name	Qty
1	262-001	Pro HD Control Panel	1
2	20000-20024	5000 PSI Panel Gauge	3
3*	814-110	#6 JIC M to #4 NPT F	3
4	60000-10040	Red Stop Button	1
5	60000-10041	Green Button	1
6	60000-10042	Black Button	1
7	Key Ignition	Key Ignition	1
8	Engine Monitoring Unit	Control	1
9*	60000-10025	Cooler Relay	1
10*	60000-10026	Inline Fuse Holder	1
11	9000-0144	control panel back plate	1
12*	60000-10031	Cord Grip .25 -38	2
13*	60000-10032	Cord Grip Lock Ring 1/2"	2
14	.25 Washer	W1/4	4
15	.25x20.75 Bolt	HH1/4X3/4	2
16*	.25 Nut	N1/4	2
17*	.3125 Washer	W5/16	4
18*	.3125x18 1 Bolt	HH5/16X1	4
19*	.375 Washer	W3/8	8
20	.375x16 125 Bolt	HH3/8X1,25	4
21*	.375 Nut	N3/8	4

**PROCESSOR BAR OIL PUMP**

Item No	Part No	Part Name	Qty
1	60000-20009	Bar Oil Pump	1
2	873-200	#4 Hose Barb to #4 NPT M 90	2
3	50000-30008	1/4" Ball Valve - 1/4" NPT M t	1
4	,375 Washer	W3/8	1
5	,375x16 l Bolt	HH3/8Xl	1

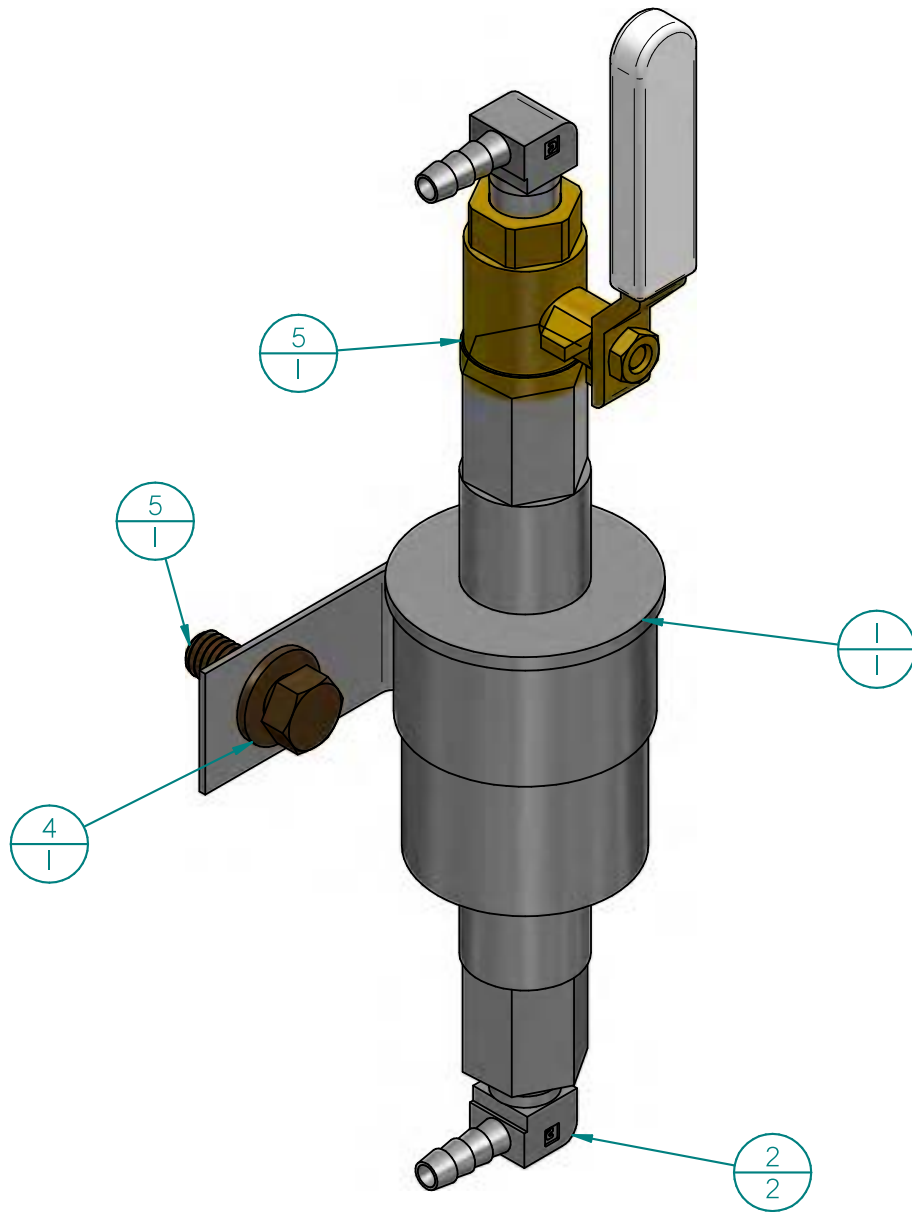

## PROCESSOR BAR OIL TANK

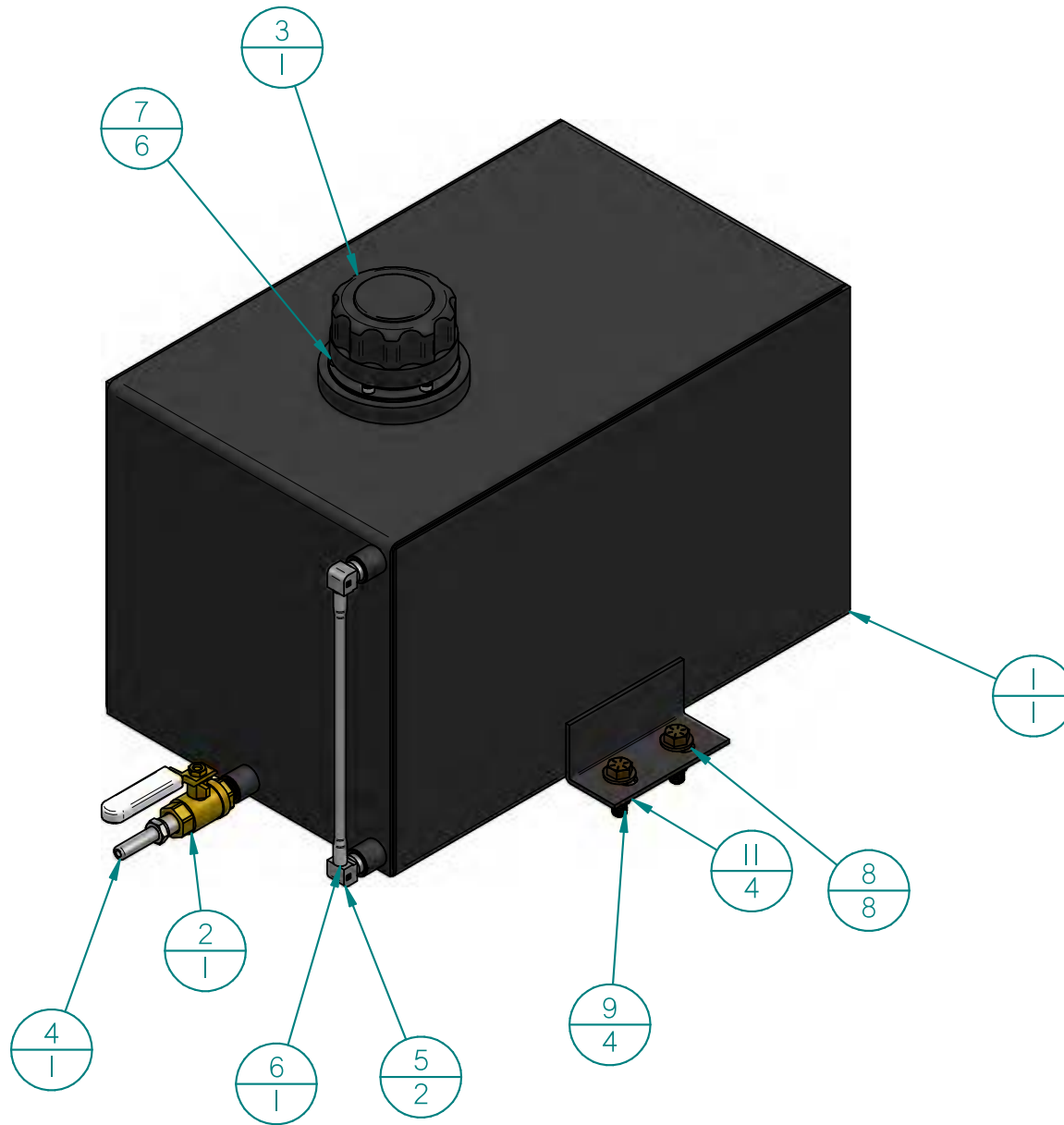

Item No	Part No	Part Name	Qty
1	9000-0042	Bar Oil Tank	1
2	50000-30008	1/4" Ball Valve - 1/4" NPT M t	1
3	20000-10004	Breather Filler	1
4	873-100	#4 Barb to #4 NPT M	1
5	873-200	#4 Hose Barb to #4 NPT M 90	2
6	10000-20001	Pro Bar Oil Sight Tube, use L67 feet per top level Pro HD	1
7	10-32 x 0,5 Socked Head	SHC10-32X1/2	6
8	.375 Washer	W3/8	8
9	.375x16 1,25 Bolt	HH3/8X1,25	4
10	.375 Nut	N3/8	4

**PROCESSOR AUTO CYCLE**

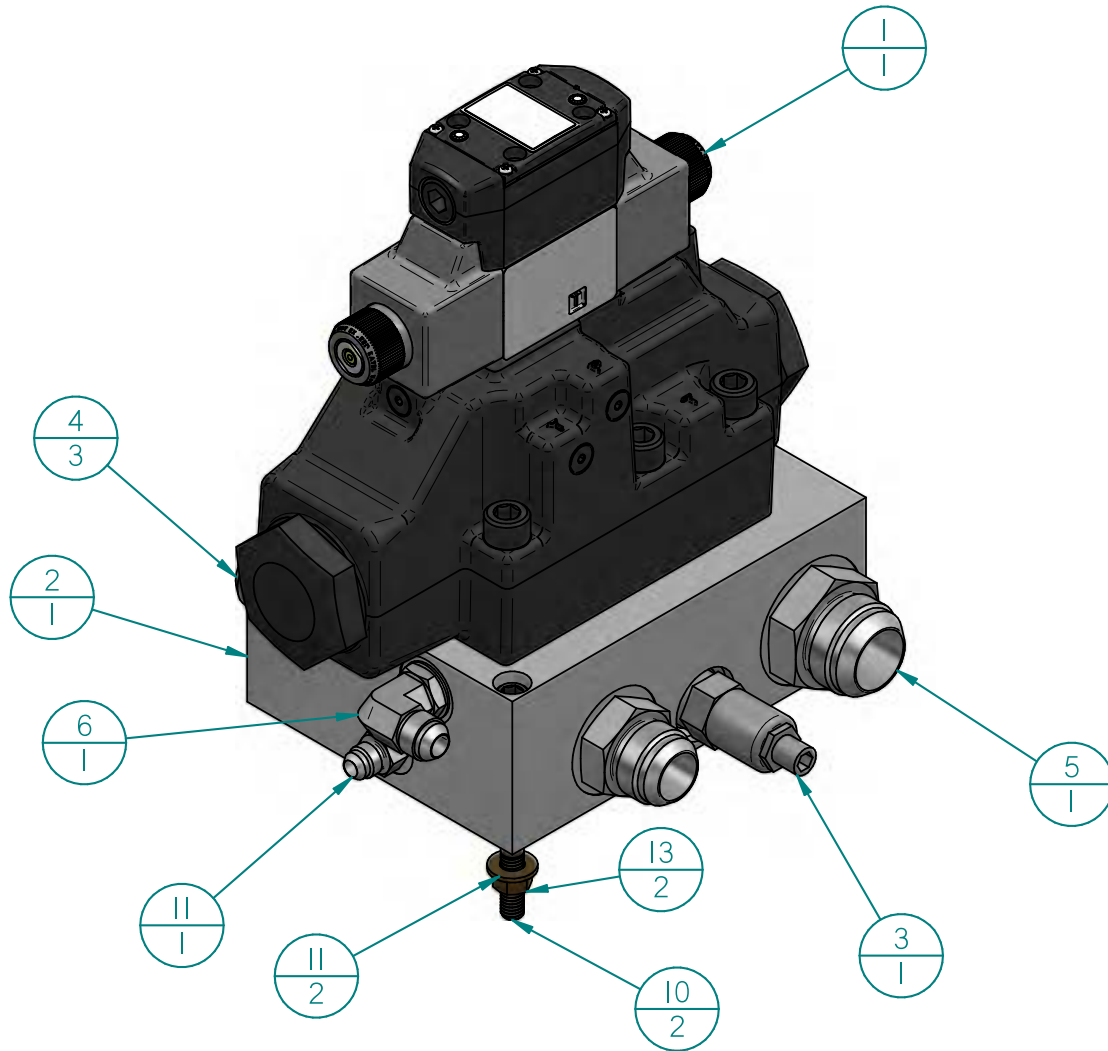

Item No	Part No	Part Name	Qty
1	50000-10006	D-08 Valve	1
2	902-002	Aluminum Manifold D08	1
3	50000-10018	Revealan Insert for D08 Manifold	1
4	815-155	#16 JIC M to #16 ORB M	3
5	815-166	#20 JIC M to #20 ORB M	1
6	815-222	#8 JIC M to #8 ORB M 90	1
7	815-111	#6 JIC M to #6 ORB M	1
8*	800-174	#16 ORB Plug	2
9*	800-175	#6 ORB Plug	1
10	.375x16 4 Socket Head Bolt	3/8"x16 4 Socket Head Bolt	2
11	.375 Washer	W3/8	2
12	.375 Nut	N3/8	2

## PROCESSOR FEED TROUGH MOTOR

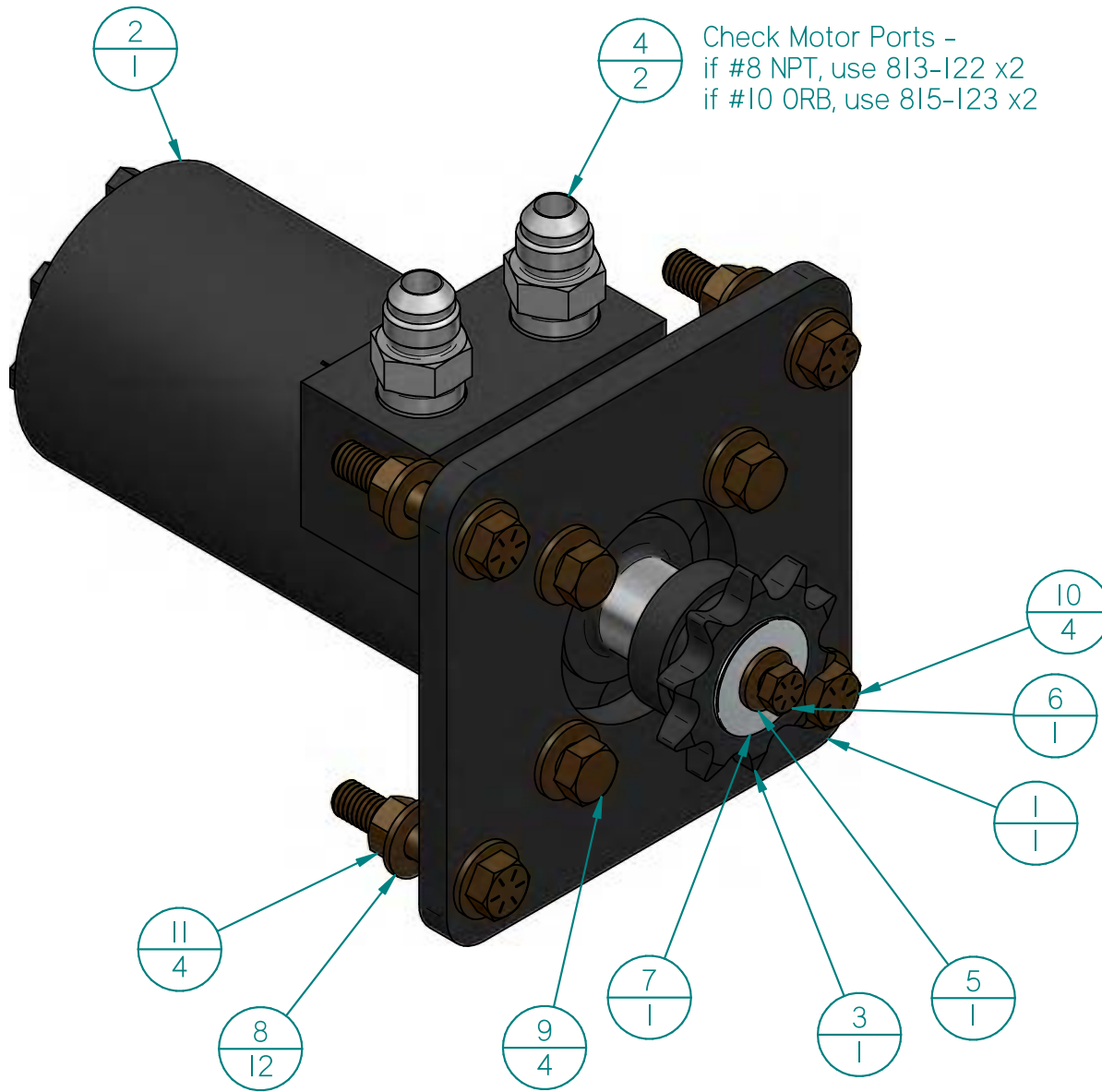

Item No	Part No	Part Name	Qty
1	9000-0013	Pro Trough Motor Mount	1
2	50000-20009	Pro TR FT Motor	1
3	30000-20005	10 teeth #50 Sprocket Martin	1
4	813-122	#8 JIC M to #8 NPT M	2
5	.25 Washer	W1/4	1
6	.25x20.75 Bolt	HH1/4X3/4	1
7	.25 Large Washer	.25" Flange Washer	1
8	.375 Washer	W3/8	12
9	.375x16 1 Bolt	HH3/8X1	4
10	.375x16 2 Bolt	HH3/8X2	4
11	.375 Nut	N3/8	4

**PROCESSOR CONVEYOR VALVE  
FOR INTEGRATED CONVEYOR  
(OPTIONAL ADD ON)**

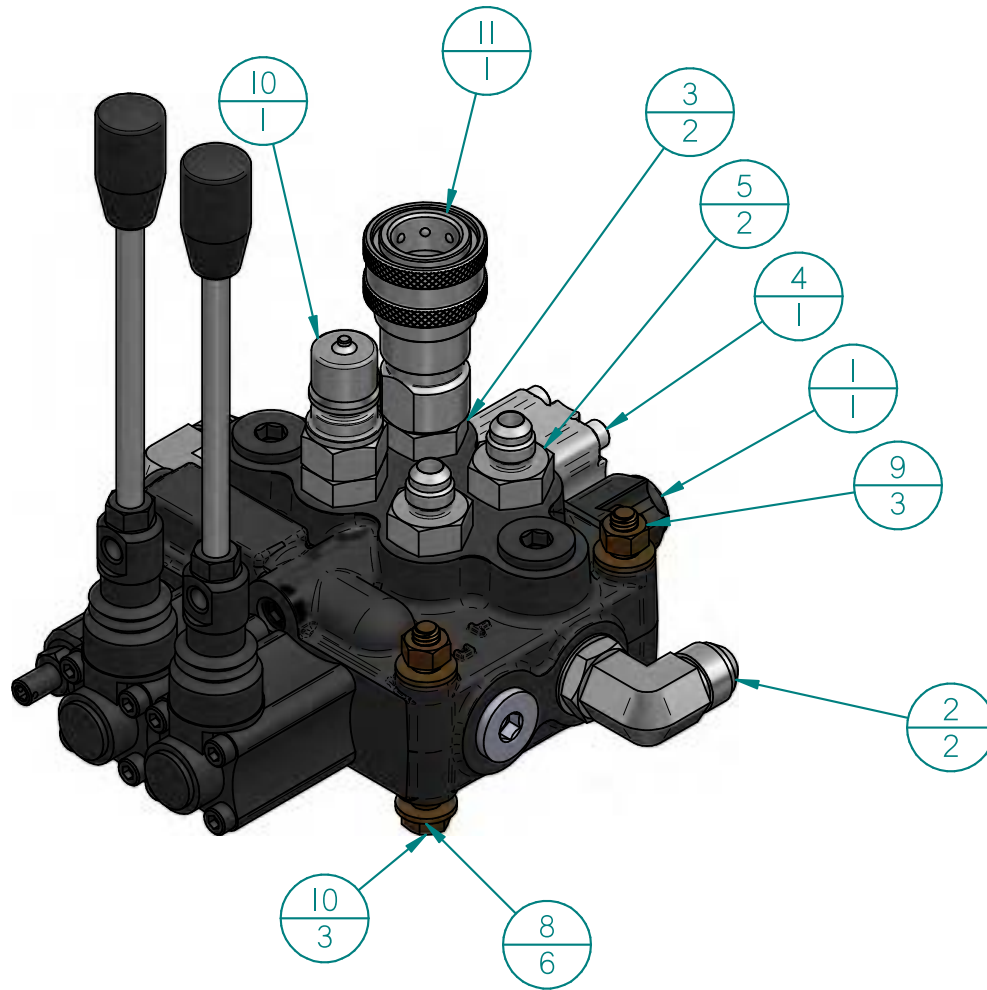

Item No	Part No	Part Name	Qty
1	50000-10004	MB 2 Spool Valve	1
2	815-222	#8 JIC M to #8 ORB M 90	2
3	835-112	#6 NPT M to #8 ORB M	2
4	262-112	3 Position Detent	1
5	815-112	#6 JIC M to #8 ORB M	2
6	800-033	#6 IMI Half Quick Disconnect	1
7	800-034	#6 IFI Half Quick Disconnect	1
8	.3125 Washer	W5/16	6
9	.3125 Nut	N5/16	3
10	.3125x18 2.5 Blot	HH5/16X2.5	3

## PROCESSOR CONVEYOR DRIVE ROLLER FOR INTEGRATED CONVEYOR (OPTIONAL ADD ON)

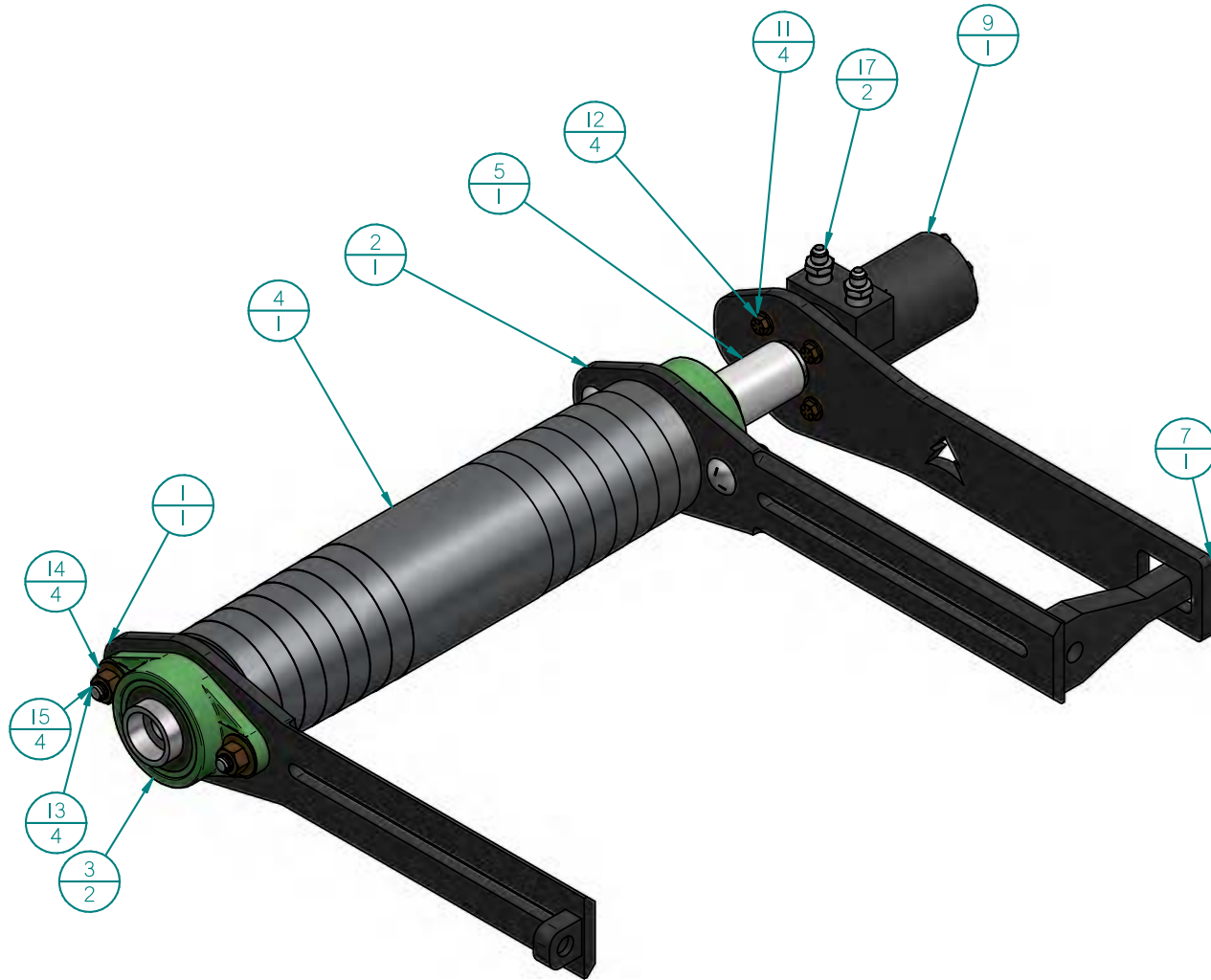

Item No	Part No	Part Name	Qty
1	252-653	TWC Idler Key Narrow	1
2	252-705	TWC Motor Key Reaction	1
3	30000-30005	1-3/4 2-bolt Flange Bearing	2
4	252-593	Conveyor Drive Roller 1.75	1
5	30000-20009	Rigid Shaft Coup w/ Keyway 1"D	1
6	10000-11012	1/4"x1.5" Key	1
7	9002-0038	Conveyor motor plate 4Bolt	1
8	253-188	Oil-Embedded Thrust Bearing	2
9	50000-20009	Pro TR FT Motor	1
10	813-112	#6 JIC M to #8 NPT M	2
11	.375 Washer	W3/8	4
12	.375x1.6 L25 Bolt	HH3/8x1.25	4
13	.625x11 2 Carriage Bolt	5/8"x11 2" Carriage Bolt	4
14	.625 Washer	W5/8	4
15	.625 Nut	N5/8	4



**PROCESSOR INTEGRATED CONVEYOR FRAME  
(OPTIONAL ADD ON)**

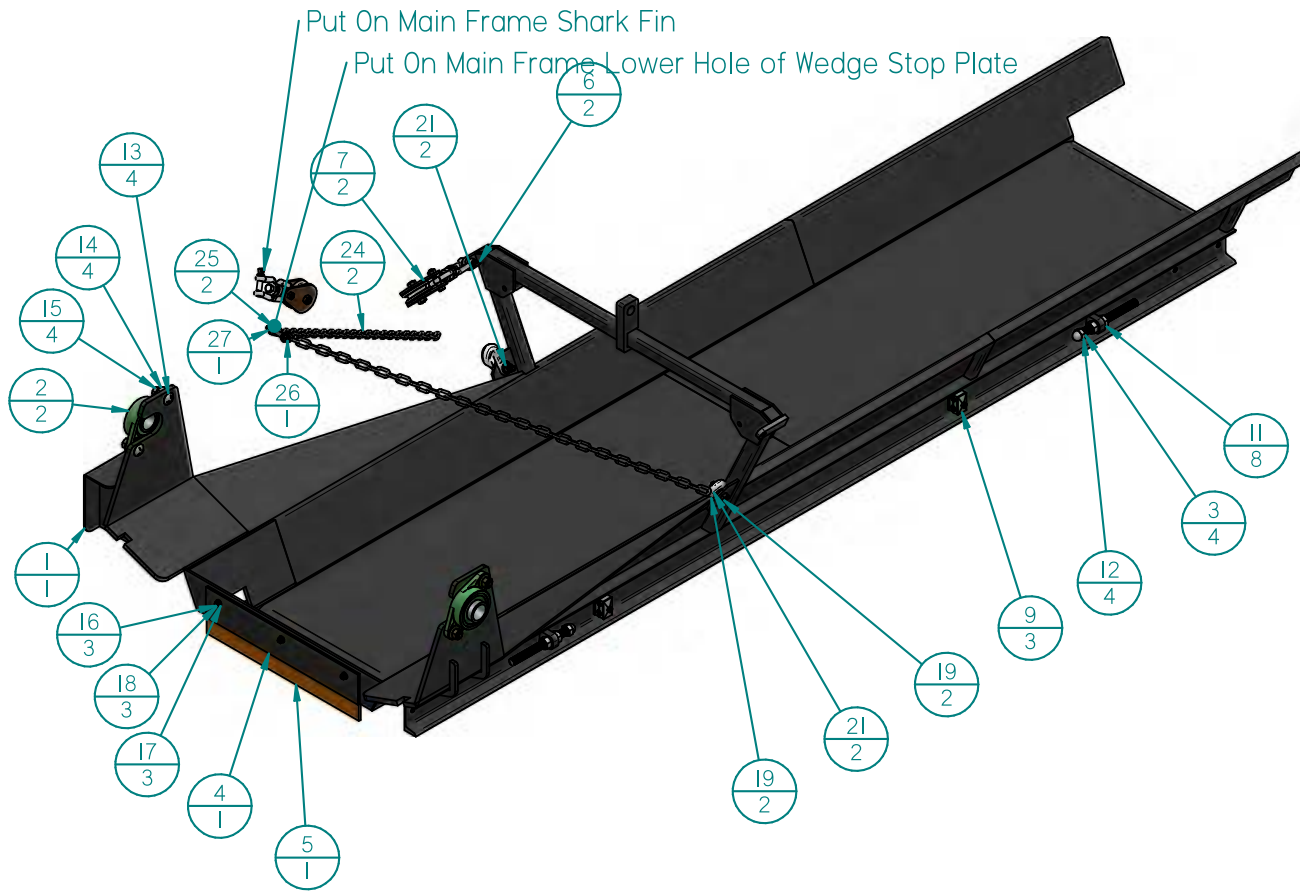

Item No	Part No	Part Name	Qty
1	262-135	Pro Conveyor 9-20-22	1
2	30000-30005	1-3/4 2-bolt Flange Bearing	2
3	9002-0036	8in 3/4-10 threaded rod	4
4	9002-0040	Conveyor Hopper Anchor	1
5	257-726	Short piece of belt material	1
6	90000-00016	3/8 Jaw & Eye Swivel	2
7	90000-00015	4000 lb Lifting Block	2
8	9000-0006	Pro Conveyor Hook	2
9	251-191-P		3
10	90000-00009 Pro	Pro 5/16" Safety Chain	2
11	.75 Nut	N3/4	8
12	.75 Cap Nut	AN3/4	4
13	.625x11 2 Carriage Bolt	5/8"x11 2" Carriage Bolt	4
14	.625 Washer	W5/8	4
15	.625 Nut	N5/8	4
16	.3125x18 1 Button	5/16"x18 1" Button Socket	3
17	.3125 Washer	W5/16	3
18	.3125 Lock Nut	NN5/16	3
19	.5x13 1.75 Bolt	1/2"x13 1.75 Bolt	2
20	.5 Washer	W1/2	2
21	.5 Lock Nut	NN1/2	2
22	.4375 Washer	W7/16	2
23	.4375x14 2.5 Bolt	7/16"x14 2.5" Bolt	1
24	.4375 Lock Nut	NN7/16	1

**PROCESSOR CONVEYOR HAND WINCH  
FOR INTEGRATED CONVEYOR  
(OPTIONAL ADD ON)**

Item No	Part No	Part Name	Qty
1	90000-00017	Haul Master 1 Ton Hand Winch	1
2	.4375 Washer	7/16" Washer	6
3	.4375x14 1 Bolt	7/16"x14 1" Bolt	3
4	.4375 Nut	7/16" Nut	3

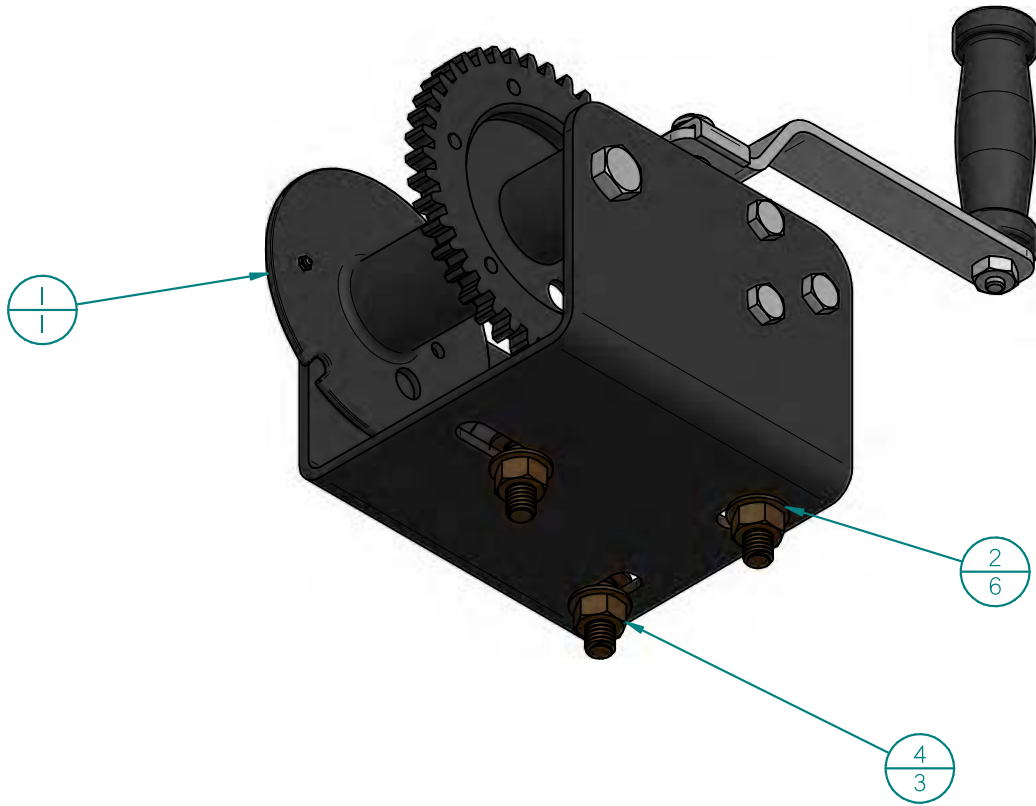

**PROCESSOR CONVEYOR IDLER ROLLER  
FOR INTEGRATED CONVEYOR  
(OPTIONAL ADD ON)**

Item No	Part No	Part Name	Qty
1	252-591	TWC Lower Left Key	1
2	252-592	Conveyor Lower Right Key	1
3	30000-30005	1-3/4 2-bolt Flange Bearing	2
4	252-594	Conveyor Idle Roller L75	1
5	Sweeper		1
6	253-188	Oil-Embedded Thrust Bearing	2
7	.25 Washer	W1/4	4
8	.25 Lock Nut	.25 Lock Nut	2
9	.25x20 L25 Bolt	1/4"X1-1/4" Bolt	2
10	.625x11 2 Carriage Bolt	5/8"X11 2" Carriage Bolt	4
11	.625 Washer	W5/8	4
12	.625 Nut	N5/8	4

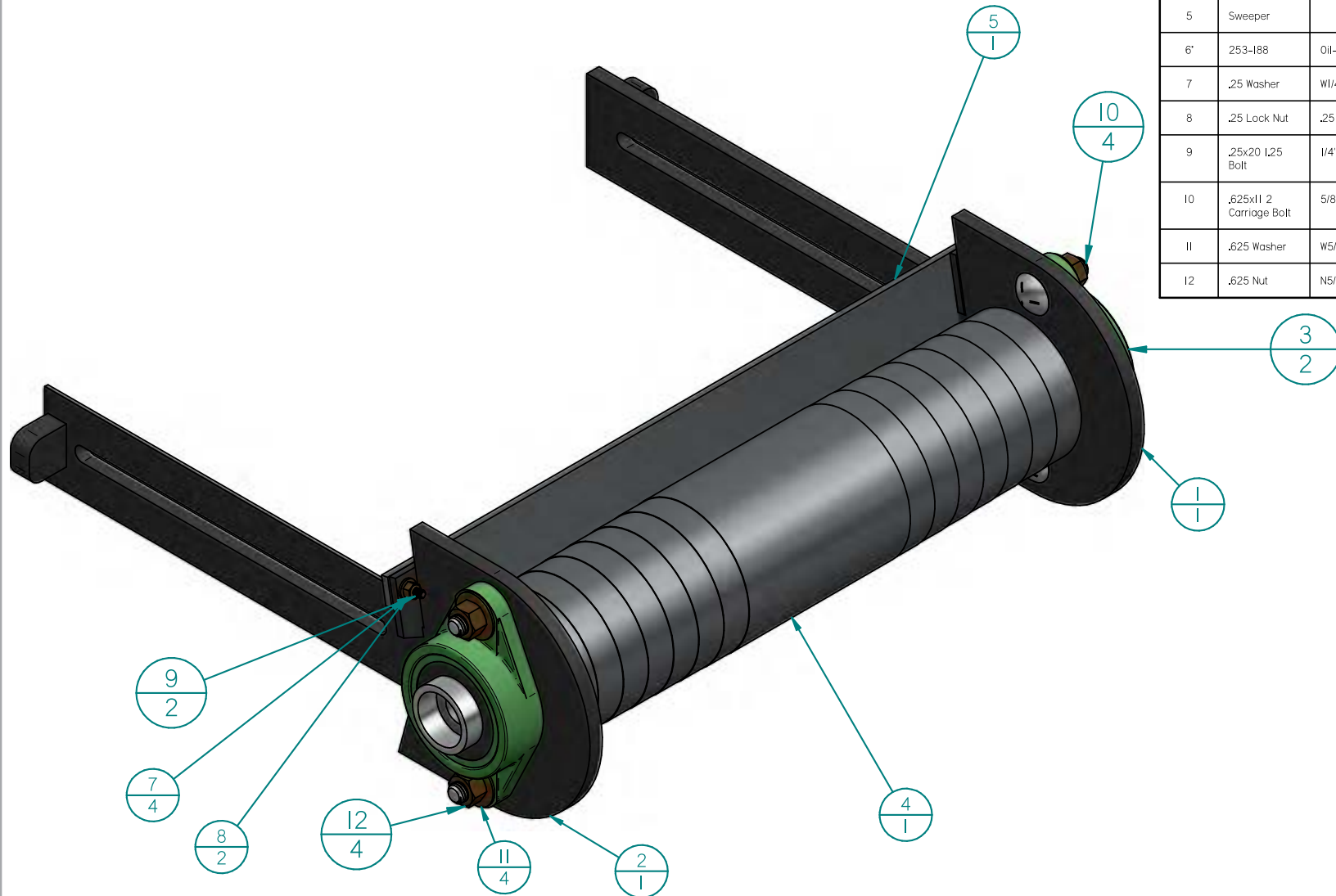

**PROCESSOR CONVEYOR TENSIONER BLOCK  
FOR INTEGRATED CONVEYOR  
(OPTIONAL ADD ON)**

Item No	Part No	Part Name	Qty
1	252-047	Conveyor Tensioner Backing Plate	1
2	.5 Washer	1/2" Washer	2
3	.5 Nut	1/2" Nut	2

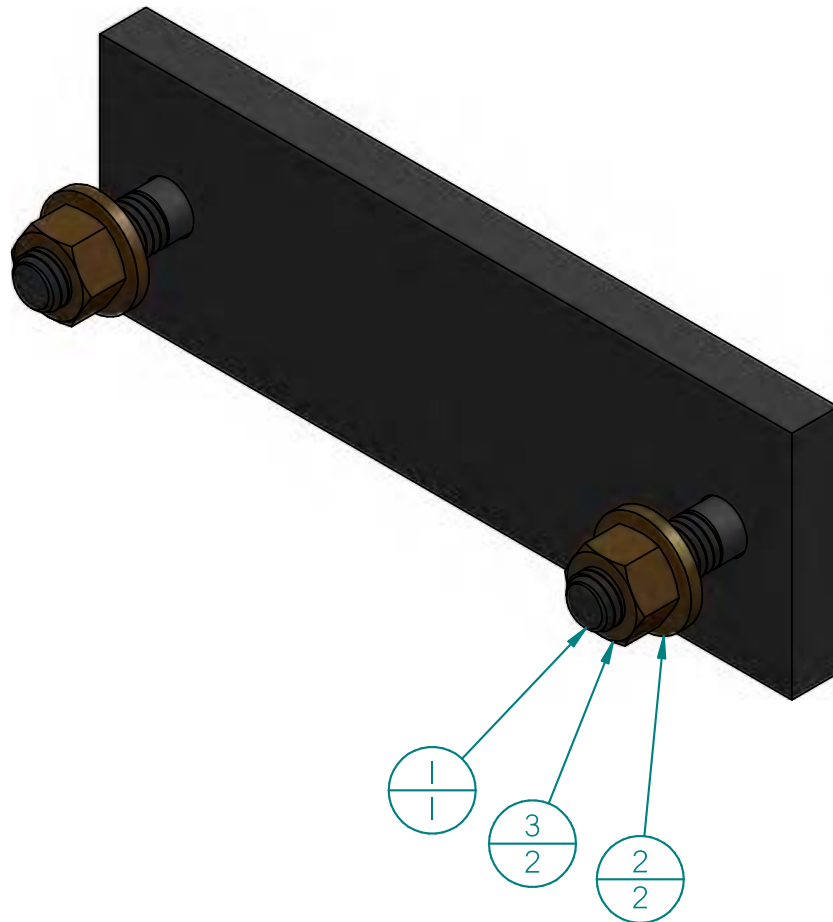

**PROCESSOR CONVEYOR LINK PLATE  
FOR INTEGRATED CONVEYOR  
(OPTIONAL ADD ON)**

Item No	Part No	Part Name	Qty
1	9000-0195	Pro Conveyor Link Plate	2
2	I Lock Nut	I Lock Nut	2
3	IX8 3,5 Bolt	IX8 3,5 Bolt	2

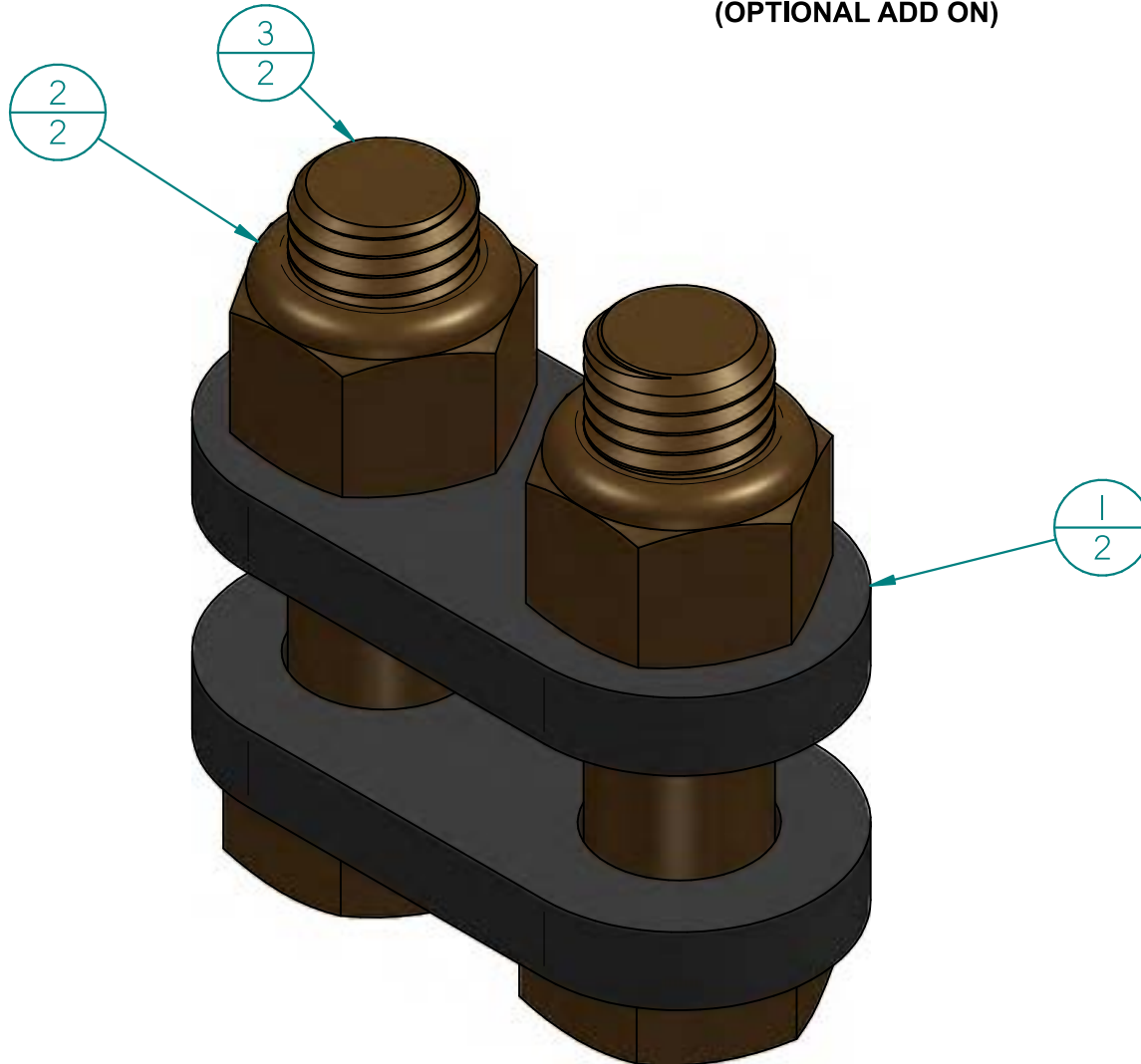

**PROCESSOR CONVEYOR PIN  
FOR INTEGRATED CONVEYOR  
(OPTIONAL ADD ON)**

Item No	Part No	Part Name	Qty
1	Already Weld On Frame	Pro Conveyor Pin 1,750DX4,75"	1
2*	1,75" Retaining Ring	1,75" Retaining Ring	1
3*	40000-10013	1-3/4" Shaft Collar	1

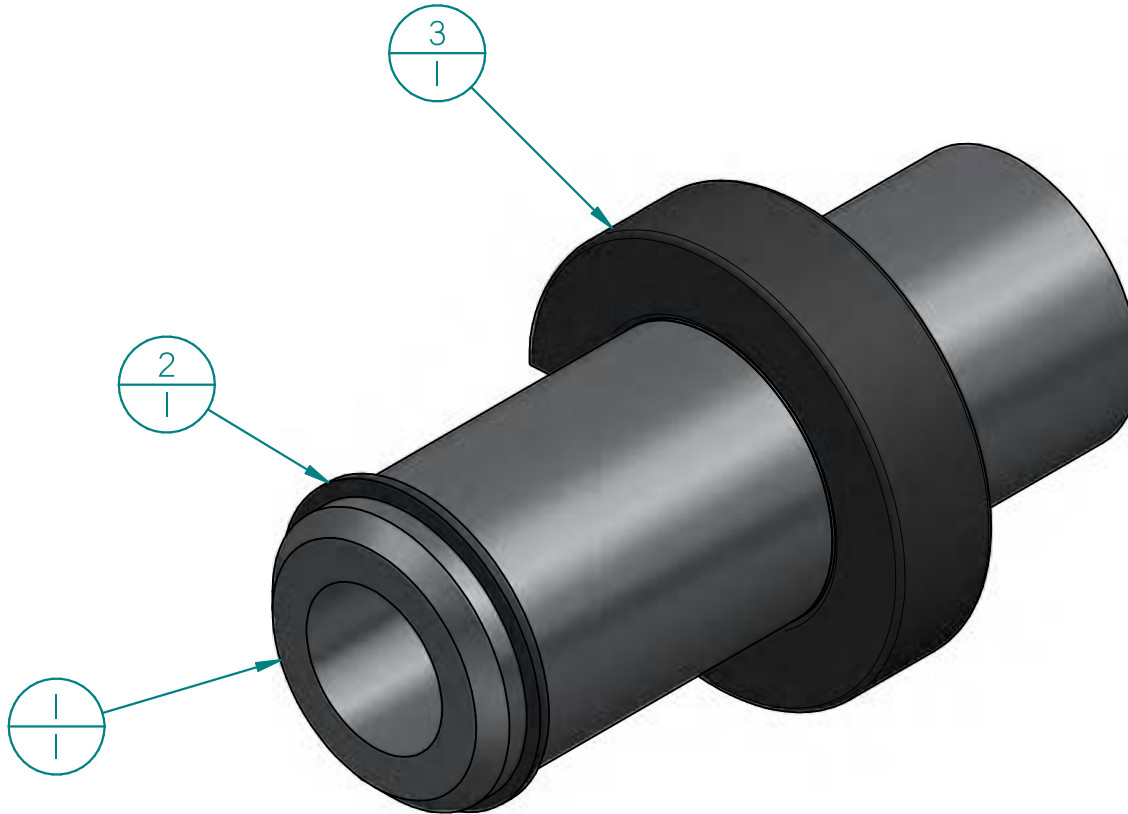

## Assembly and Repair - Pro-MP, MP X, MP XL

With normal use of the processor, replacement parts and repairs may be needed. Reference the "Assembly and Repair" section for parts, part quantities and assembly instructions.

**Pro-MP, Pro-MP X, Pro-MP XL**





### PRO-MP, MP X, MP XL MAIN FRAME

Note: Use 1x 800-053 and 2x 873-166 for 22-2.7 pumps version,  
Use 3x 873-166 for 22-18-2.7 pumps version

Item No	Part No	Part Name	Qty
1	9000-0253	Pro MP Mainframe II-9-23	1
2	90000-00010	Processor Ball Coupler	1
3	use 90000-00009 x4 ft and 900000-00013 x2	use 90000-00009 x4 ft and 900000-00013 x2	2
4	9000-0047	Pro HD Jack I	4
5	90000-00018 x5	73 hub 58 spring center 6k axle for MP. underslung version, half of 90000-00018	1
6	90000-00011	6 Lug Wheel	2
7	813-156	#16 JIC M to #20 NPT M	1
8	9001-0212	#12 3/4" NPT Plug Drilled	1
9	873-144	#12 Barb to #12 NPT M	1
10	813-244	#12 JIC M to #12 NPT M 90	1
11	873-166	#20 Barb to #20 NPT M	3
12	800-053	1 1/4 Plug #20 NPT	1
13	20000-10004	Breather Filler	1
14	20000-20027	Sight Level Gauge	1
15	10000-20004	1/2" Thick x 3" W Plastic 5'	3
16	W1/2	W1/2	36
17	HH1/2x2	HH1/2X2	16
18	NI1/2	NI1/2	16
19	HH1/2x5	.5x13 5 Bolt	2
20	NN1/2	NN1/2	2
21	W7/16	W7/16	4
22	HH7/16x1.75	7/16"x14 1.75" Bolt	2
23	NN7/16	NN7/16	2

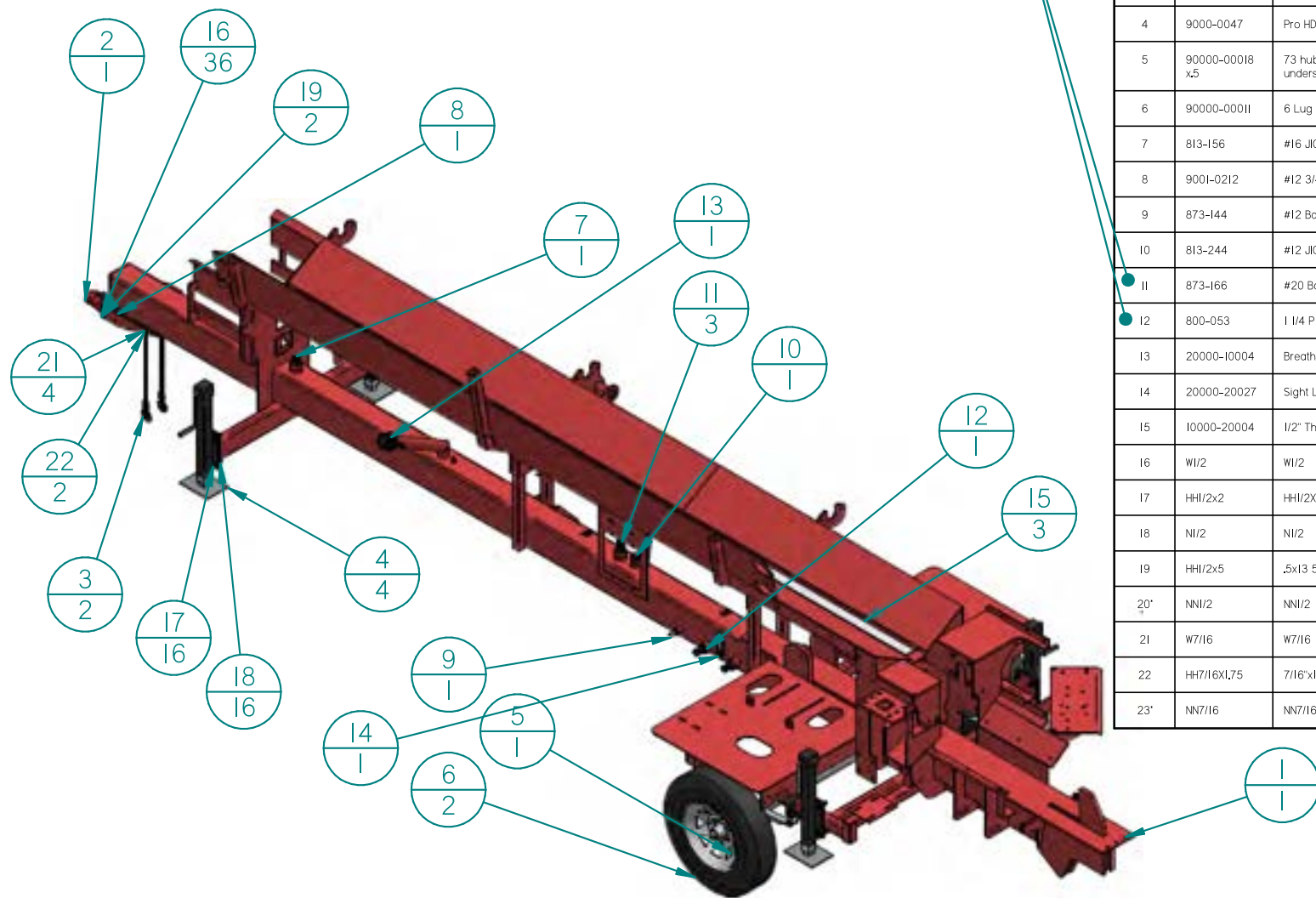

**PRO-MP, MP X, MP XL PUSH BLOCK**

Item No	Part No	Part Name	Qty
1	9000-0200	Pro MP Push Block 3-14-23	1
2	9001-0035	Alpha 5/8" Push Block Shim	2
3	9001-0003	18" x1" x 2" Wear Plate	2
4	Grease Fitting 1/4	1/4 Grease Fitting	6
5	LW1/2 W	.5 Wedge Lock Washer	14
6	HH1/2x3,5	HH1/2X3,5	14
7	NI1/2	NI1/2	14

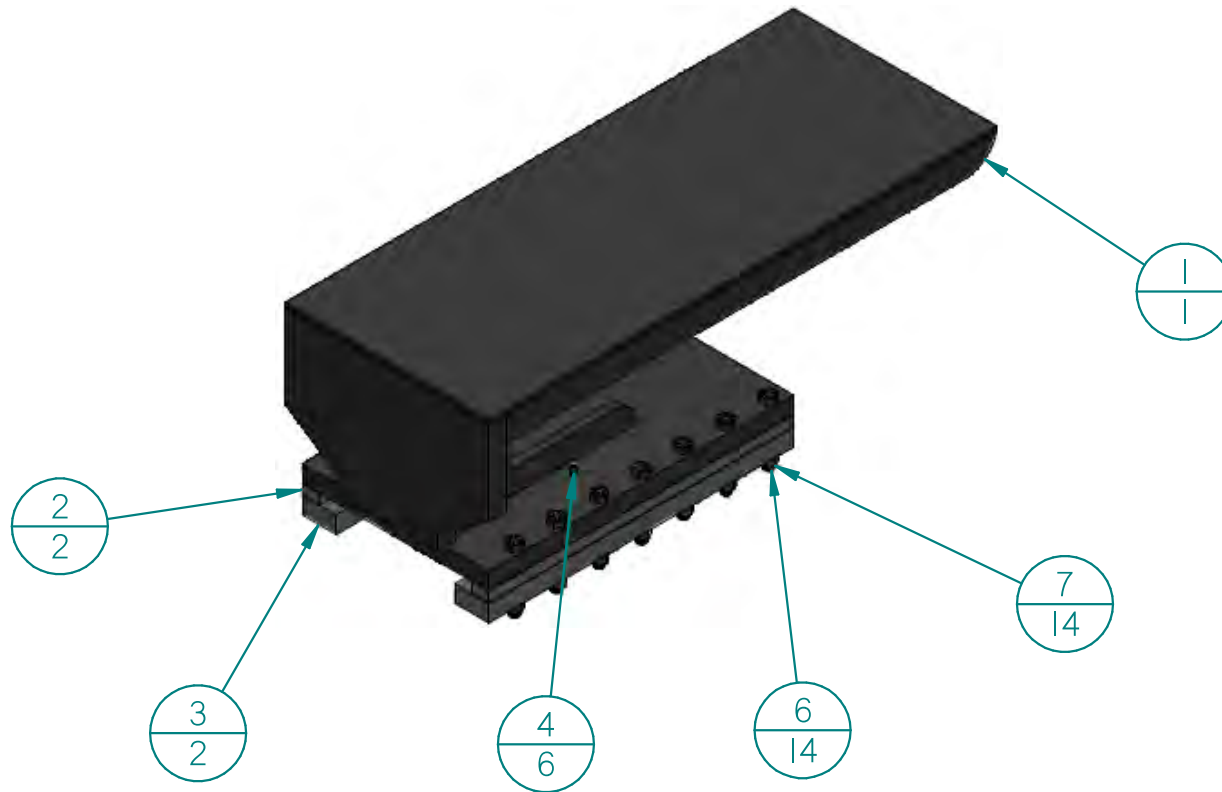

### PRO-MP, MP X, MP XL FEED TROUGH MOTOR

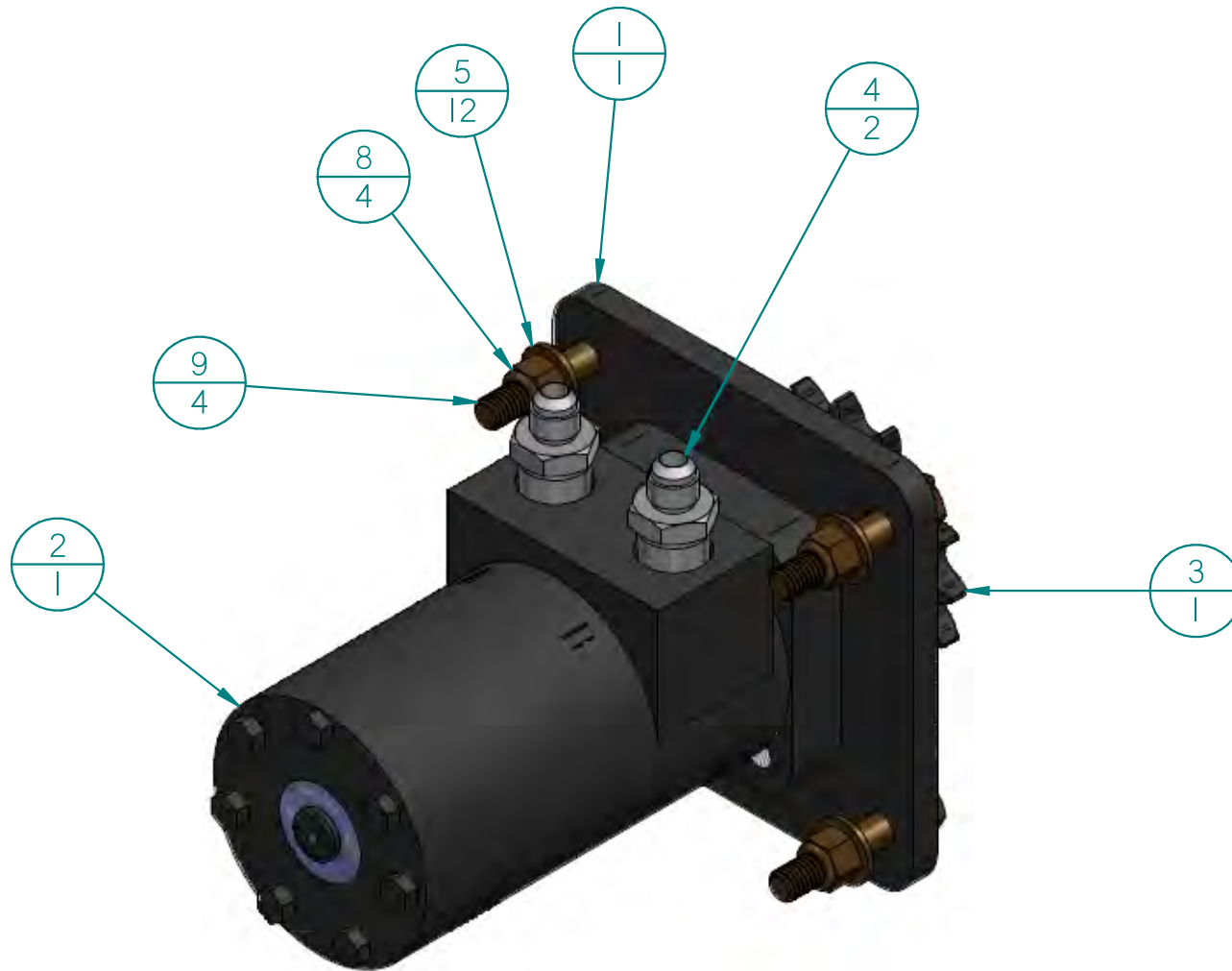

Item No	Part No	Part Name	Qty
1	9000-0013	Pro Top Roll Motor Mnt	1
2	50000-20018	Anfield Hydraulic Motor 125 4 bolt	1
3	30000-20014	#50 Chain 16 Tooth Sprocket 1" shaft McMaster PN 6280K931	1
4	813-112	#6 JIC M to #8 NPT M	2
5	W3/8	W3/8	12
6	LW3/8	3/8" Spring Washer	4
7	HH3/8x1	HH3/8X1	4
8	NN3/8	NN3/8	4
9	HH3/8x2	HH3/8X2	4
10	W1/4	W1/4	1
11	LW1/4	1/4" Lock Washer	1
12	HH1/4x3/4	HH1/4X3/4	1
13	FW1/4	.25" Flange Washer	1

**PRO-MP, MP X, MP XL LIVE DECK MOTOR**

Item No	Part No	Part Name	Qty
1	9000-0130	Pro Top Roll Motor Mnt	1
2	9000-0027	PRO TR Motor Adjuster Plate	1
3	50000-20009	Pro TR FT Motor	1
4	813-212	#6 JIC M to #8 MNPT 90	2
5	9000-0166	Pro Live Deck Sprocket for 315 Motor	1
6	FW1/4	.25" Flange Washer	1
7	W1/4	W1/4	1
8	HH1/4x3/4	HH1/4X3/4	1
9	W3/8	W3/8	4
10	HH3/8x1	HH3/8X1	4
11	W1/2	W1/2	2
12	N1/2	N1/2	2

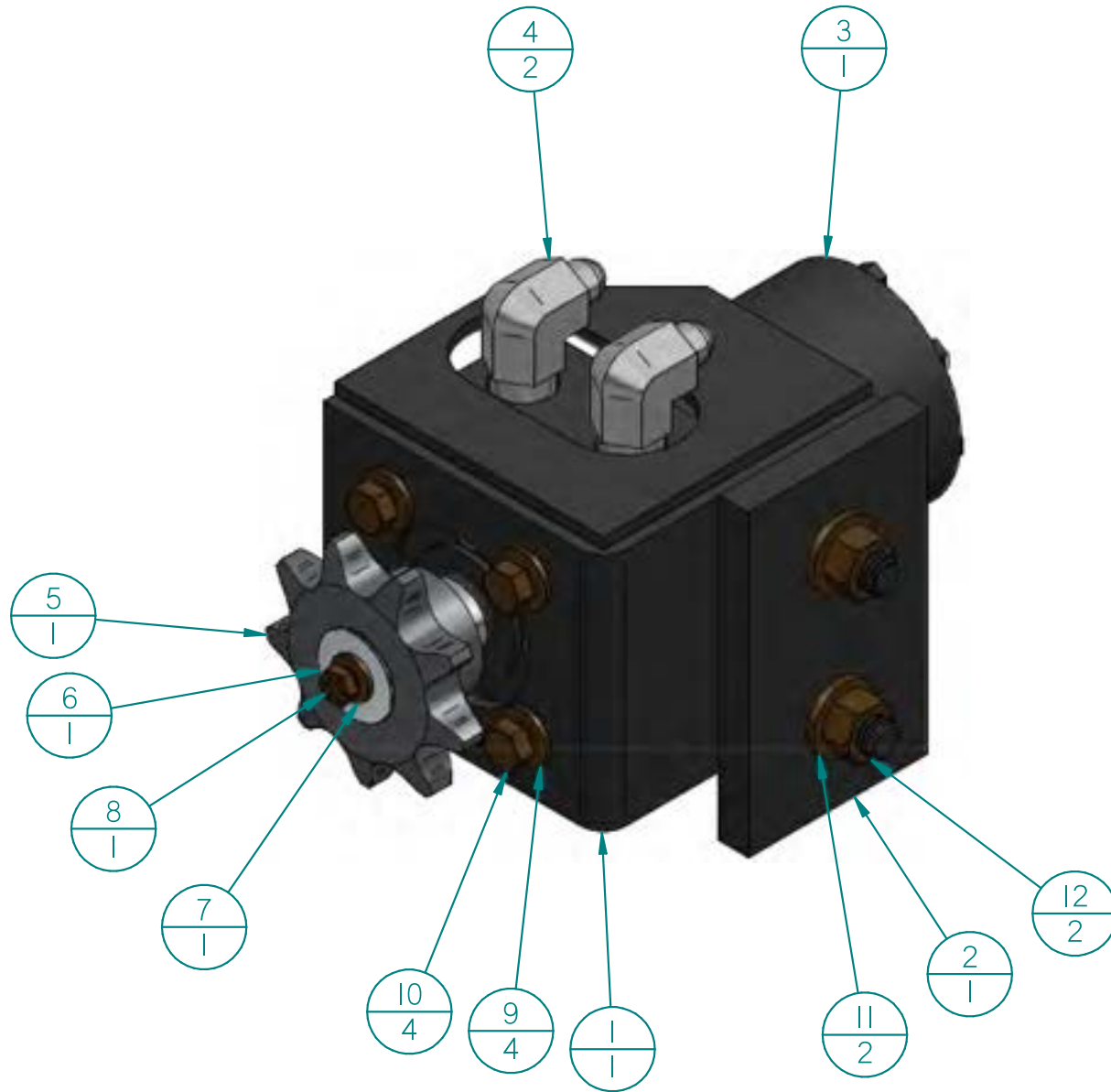

**PRO-MP, MP X, MP XL PUSH BLOCK  
CYLINDER WITH REGEN VALVE**

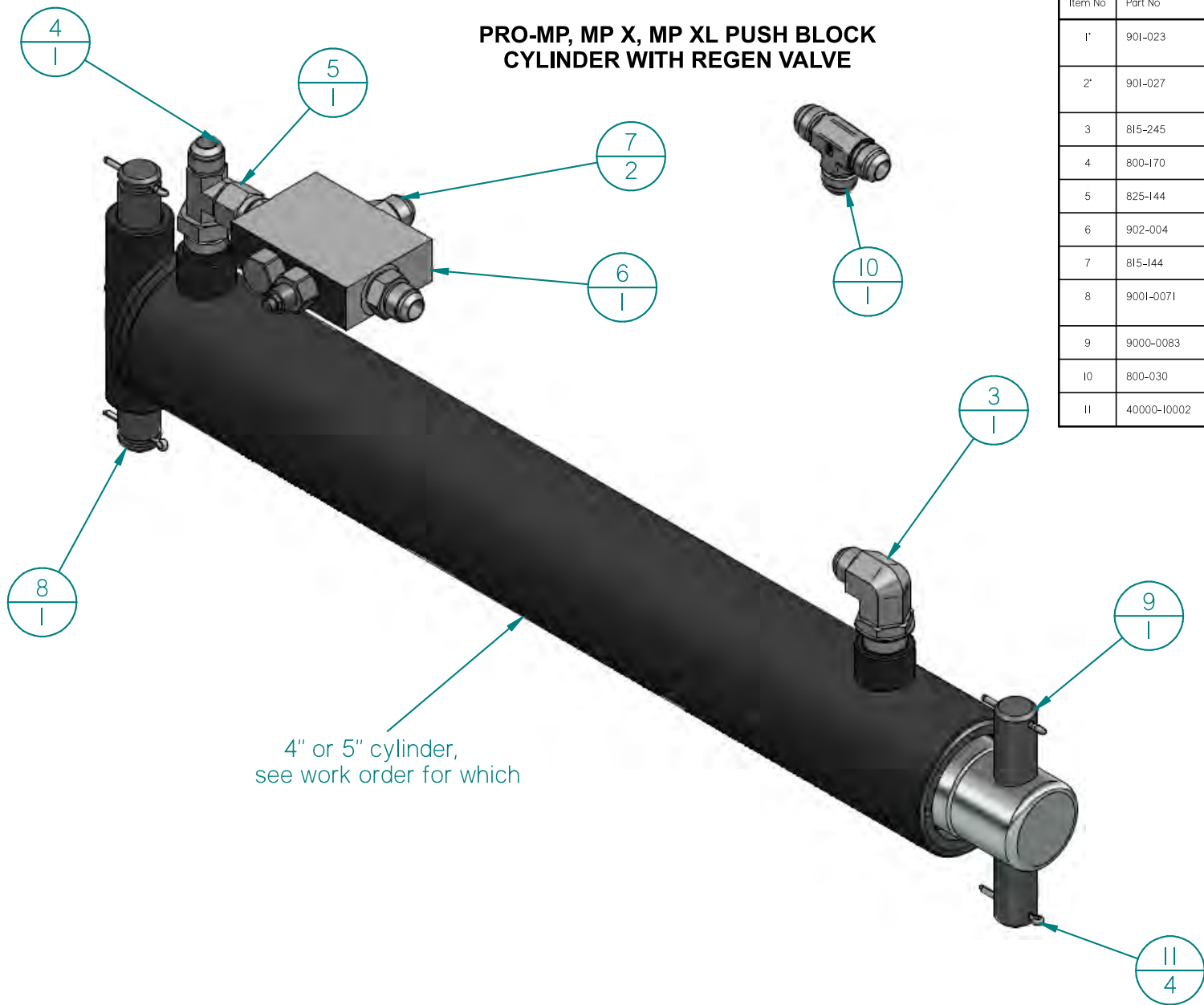

Item No	Part No	Part Name	Qty
1'	901-023	4x26x3 Pro MP Cylinder 8-28-23	1
2'	901-027	5x26x3,5 Pro MP Cylinder 8-28-23	1
3	815-245	#12 JIC M to #16 ORB M 90	1
4	800-170	#12 JIC M # 12 JIC M # 16 ORB M	1
5	825-144	#12 JIC F to #12 ORB M	1
6	902-004	Alpha Regeneration Manifold	1
7	815-144	#12 JIC M to #12 ORB M	2
8	9001-0071	Pin I,25x9,688 Alpha Cylinder Pin Bore	1
9	9000-0083	Cylinder Pin I,25X6,938	1
10	800-030	#12 Union Male JIC Tee F5705	1
11	40000-10002	Zn Cotter Pin 3/16" x 1-1/2" L	4

**PROCESSOR LIVE DECK CYLINDER**

Item No	Part No	Part Name	Qty
1	262-303	4x12x3 Pro MP Live Deck Cylinder 8-28-23	1
2	815-212	#6 JIC M to #8 ORB M 90	2
3	258-947	Pin L25D 6.622UL	1
4	40000-10002	Zn Cotter Pin 3/16" x 1-1/2" L	2

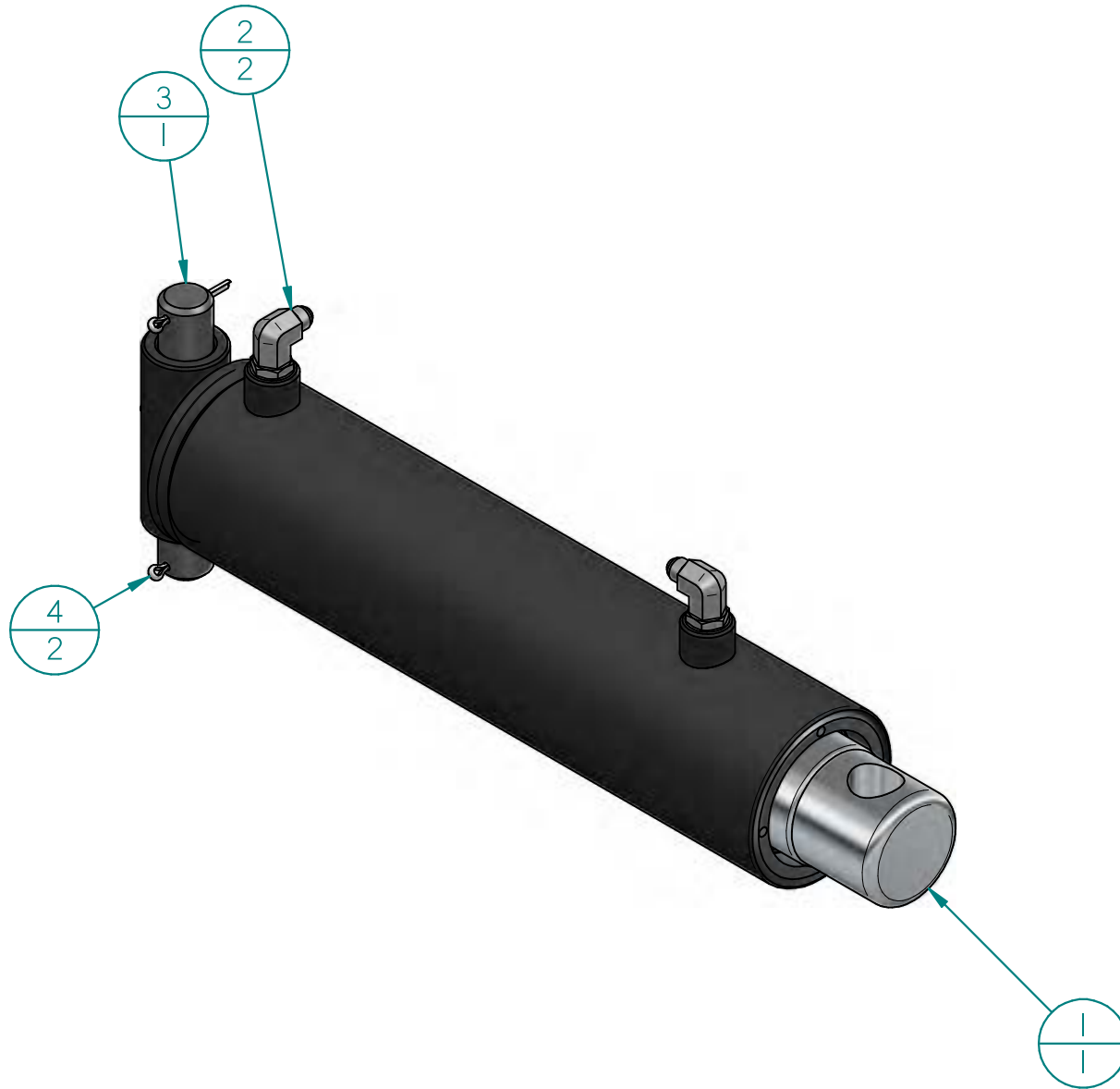

**PROCESSOR SAW CYLINDER #4 ORB**

Item No	Part No	Part Name	Qty
1	50000-30021	Magister 1.5" x 8" Saw Cylinder	1
2	50000-10014	RD 1850 Pressure Relief	1
3	856-101	#4 ORB M to #6 ORB F Reduser	1
4	835-121	#8 NPT M to #6 ORB M	1
5	813-112	#6 JIC M to #8 NPT M	1
6	815-110	#6 JIC M to #4 ORB M	1
7	800-091	#6 TEE JIC M x JIC F Swi x JIC M	1
8	813-212	#6 JIC M to #8 M NPT 90	1

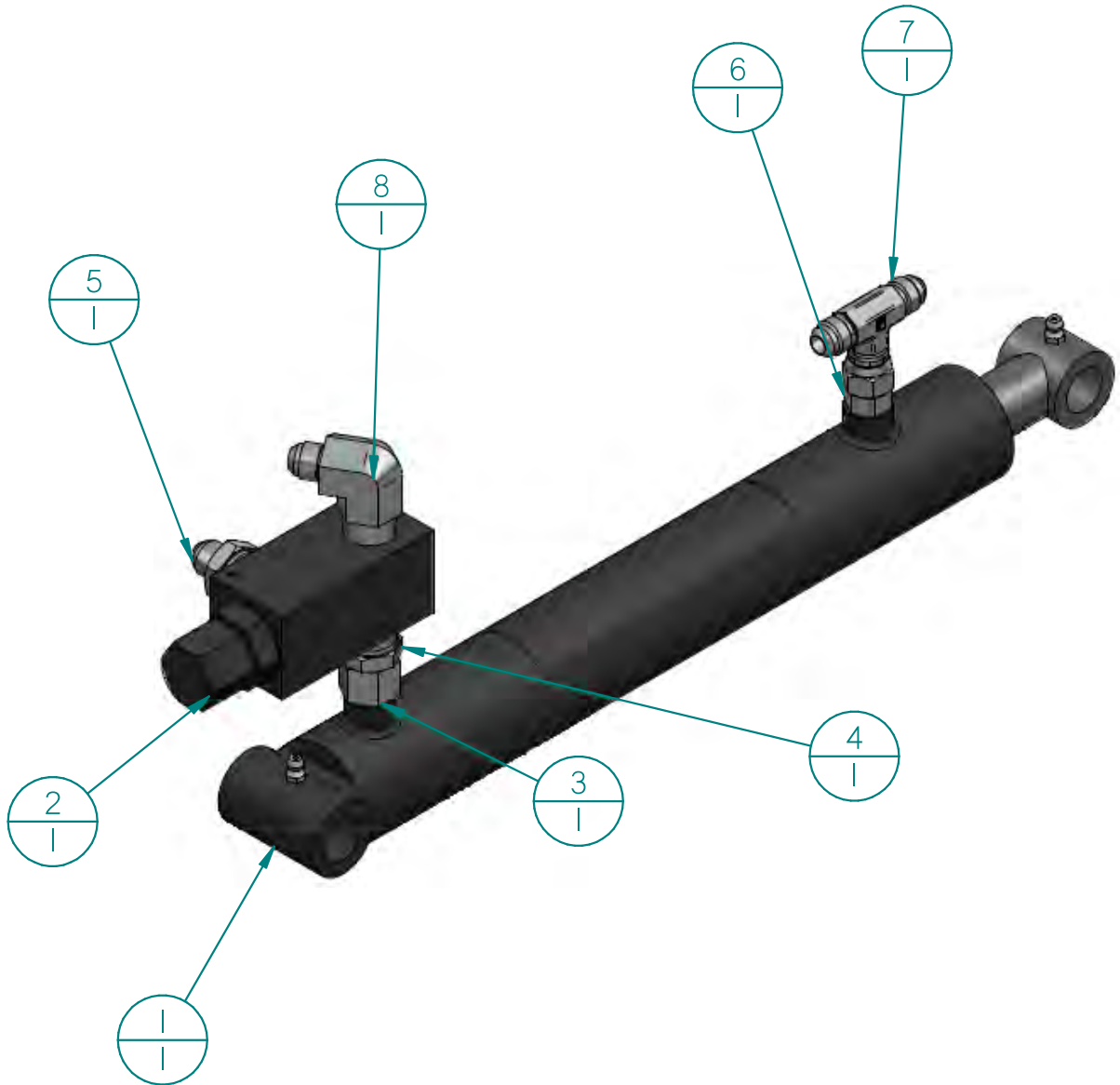



**PROCESSOR TOP ROLL CYLINDER**

Check port size on cylinder -

if cylinder has #6 ports, use 815-111x1 and 835-121 x1

if cylinder has #8 ports, use 815-112 x1 and 835-122 x1

Item No	Part No	Part Name	Qty
1	256-008	2"x24" Cylinder #8 Ports	1
2	835-122	#8 NPT M to #8 ORB M	1
3	815-112	#6 JIC M to #8 ORB M	1
4	50000-10014	RD 1850 Pressure Relief	1
5	800-091	#6 TEE JIC M xJIC F Swi xJIC M	1
6	813-212	#6 JIC M to #8 M NPT 90	1
7	813-112	#6 JIC M to #8 NPT M	1

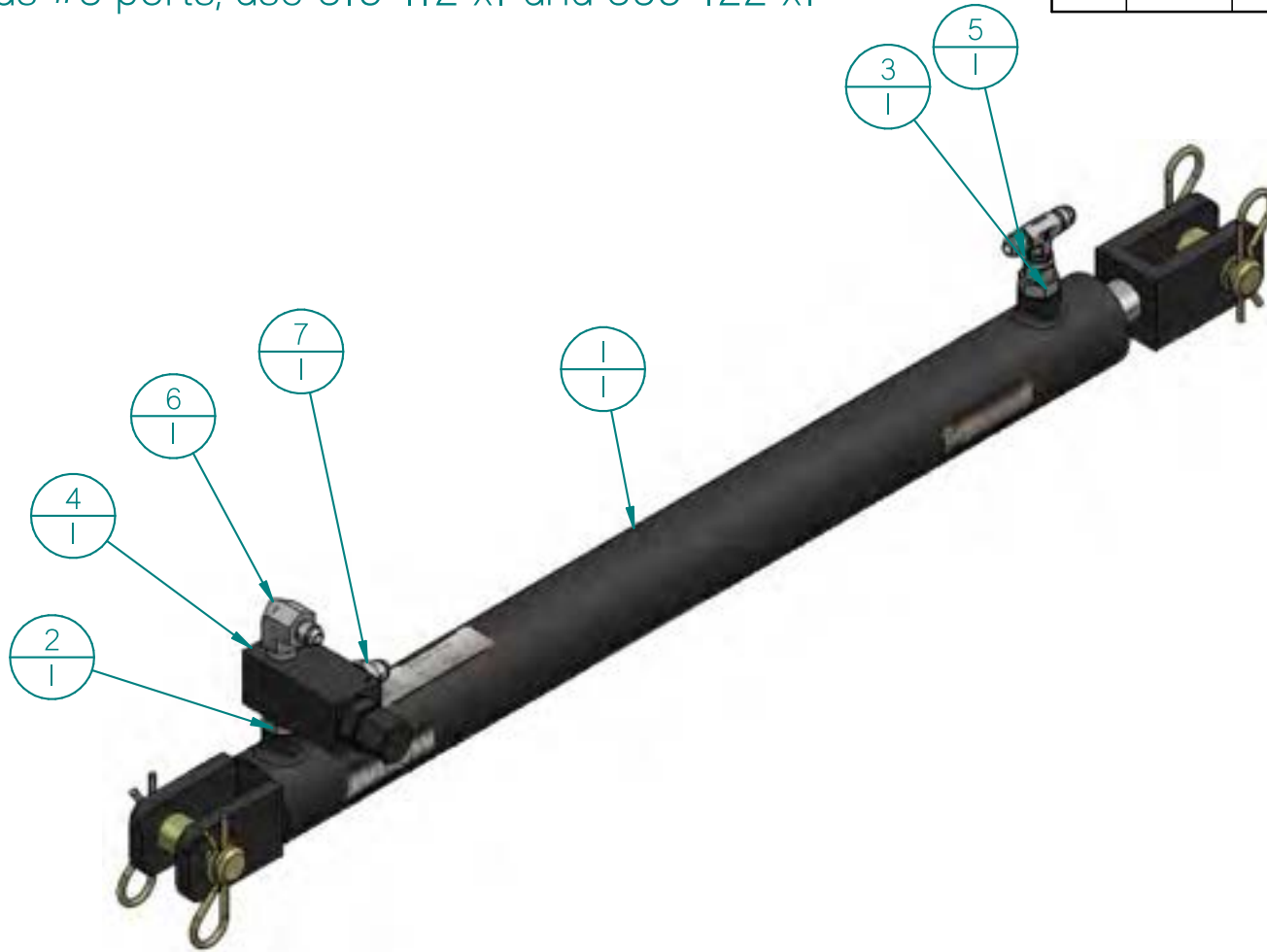

## PROCESSOR TOP ROLL UPRIGHT

Item No	Part No	Part Name	Qty
1	9000-0235	Pro Top Roll Upright 8-11-23	1
2	20000-30000	#6 Soft Line Clamp Plastic	2
3	W1/2	W1/2	16
4	HH1/2x1,75	1/2"x13 1,75 Bolt	8
5	N1/2	N1/2	8
6	HH5/16x2	HH5/16X2	2

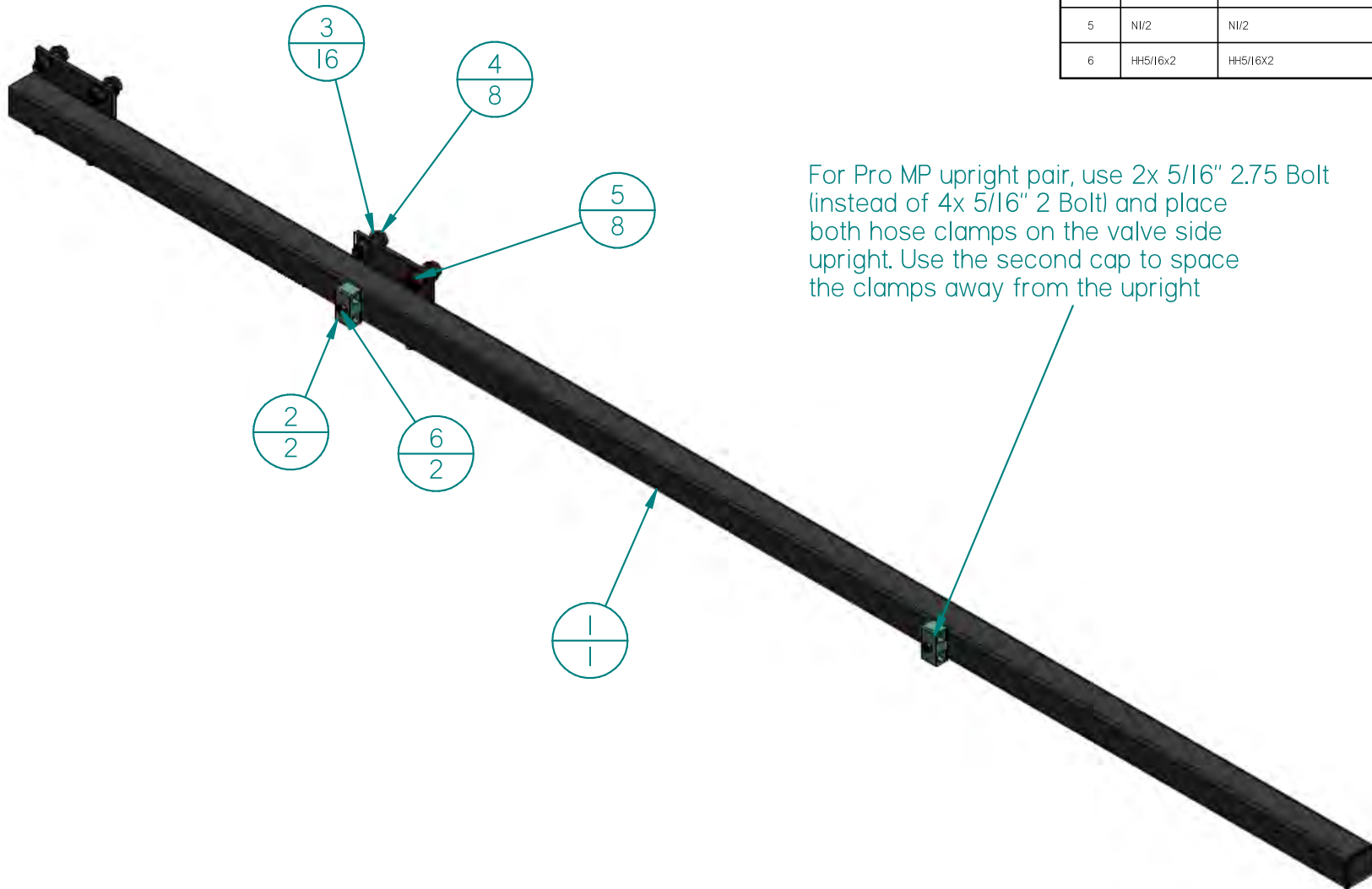

For Pro MP upright pair, use 2x 5/16" 2.75 Bolt (instead of 4x 5/16" 2 Bolt) and place both hose clamps on the valve side upright. Use the second cap to space the clamps away from the upright

**PROCESSOR TOP ROLL SPAN**

Item No	Part No	Part Name	Qty
1	9000-0035	Pro Toll Roll Span	1
2	W1/2	W1/2	8
3	N1/2	N1/2	4
4	HH1/2x3.5	HH1/2X3.5	4

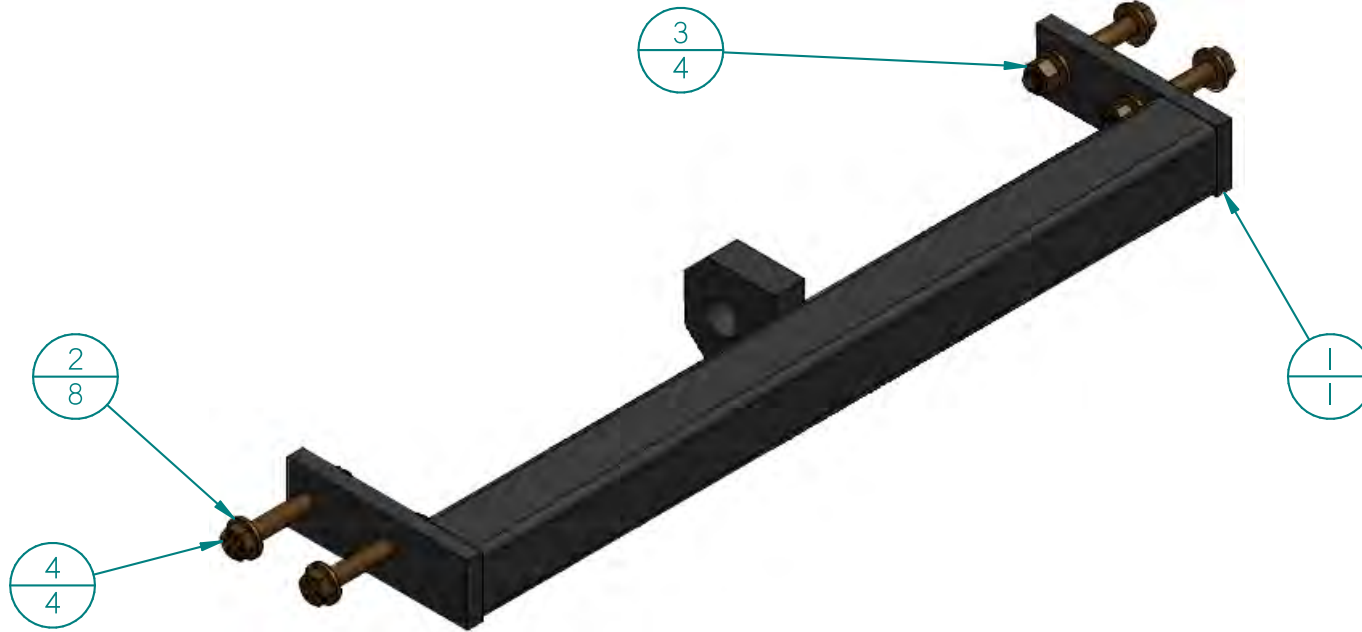

## PROCESSOR TOP ROLLER

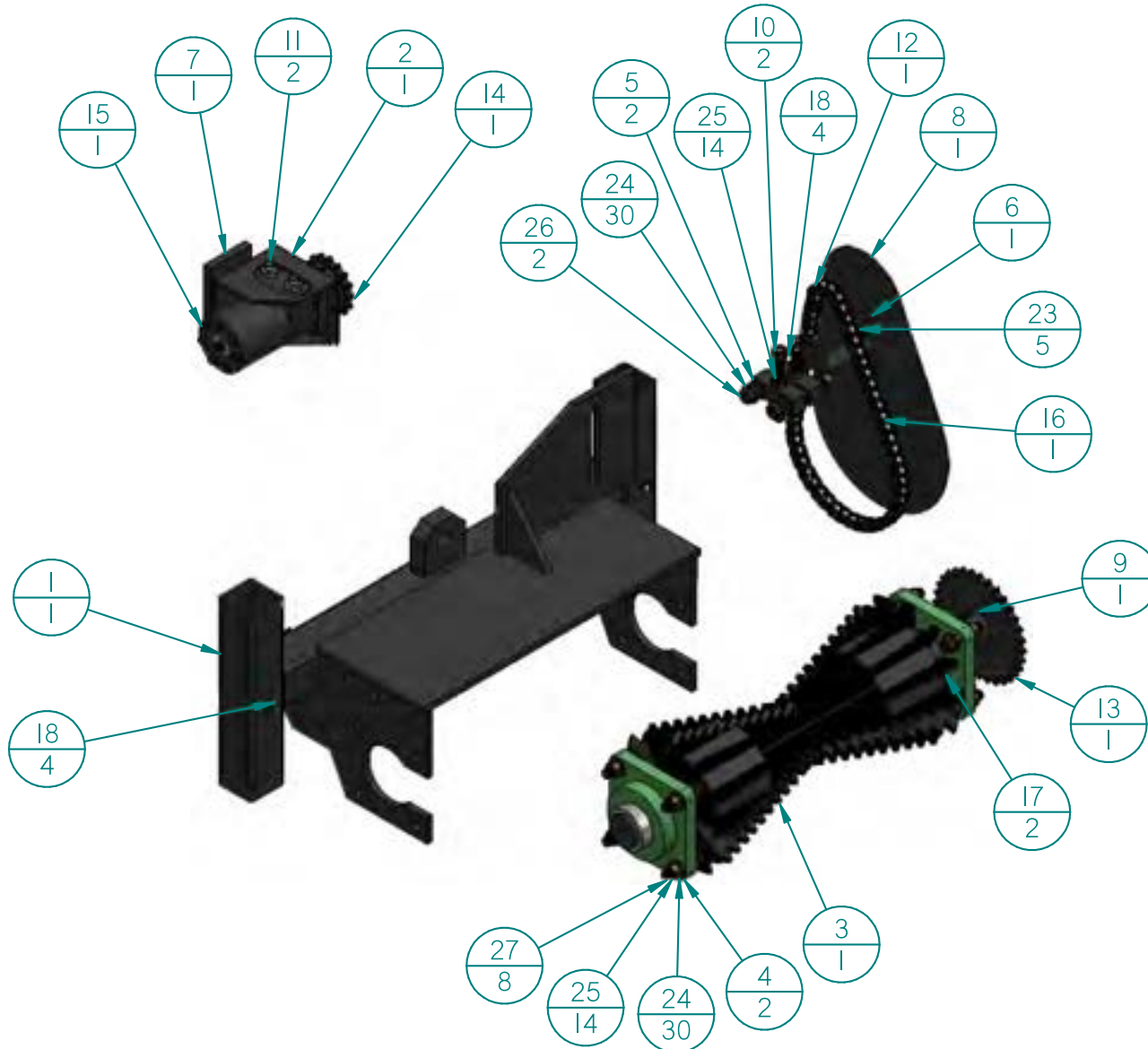

Item No	Part No	Part Name	Qty
1	9000-0121	Pro Top Roll Slide	1
2	9000-0130	Pro Top Roll Motor Mnt	1
3	9000-0055	Pro Top Roller	1
4	30000-30006	4 Bolt Flange UCF210-31	2
5	9000-0028	Top Roll Tensioner Block	2
6	9000-0011	Pro TR Chain Guard	1
7	9000-0027	PRO TR Motor Adjuster Plate	1
8	9000-0030	Top Roller Chain Guard Finish	1
9	Can Use: 10000-11015	0.5x0.5xL375 Key	1
10	9000-0002	Pro TR Tensioner Rod	2
11	813-112	#6 IIC M to #8 NPT M	2
12	30000-10010	#50 Master Link	1
13	30000-20013	#50 Chain 32 Tooth Sprocket 1-15/16" shaft McMaster PN: 6236K296	1
14	30000-20014	#50 Chain 16 Tooth Sprocket 1" shaft McMaster PN: 6280K931	1
15	50000-20018	Anfield Hydraulic Motor 125 4 bolt	1
16	Use: 30000-10002 x75 total on processors for TR and FT drives	#50 Chain	1
17	40000-10015	1-15/16 Shaft Collar	2
18	Grease Fitting 1/4 90	.25 Grease Fitting 90	4
19	FW1/4	.25" Flange Washer	1
20	W1/4	W1/4	1
21	HH1/4x.75	HH1/4X3/4	1
22	W3/8	W3/8	5
23	HH3/8x1	HH3/8X1	5
24	W1/2	W1/2	30
25	N1/2	N1/2	14
26	HH1/2x4	HH1/2X4	2
27	HH1/2X2.25	HH1/2X2.25	8

**PROCESSOR FRONT SPROCKET**

Item No	Part No	Part Name	Qty
1	9000-0089	Pro Front Wheel 9-5-23	1
2	30000-30006	4 Bolt Flange UCF210-31	2
3	30000-20013	#50 Chain 32 Tooth Sprocket	1
4	10000-11015	1/2"x1.5" Key	1
5	40000-10015	1-15/16 Shaft Collar	2
6	.5 Washer	W1/2	16
7	.5 Nut	N1/2	8
8	.5x13 2.25 Bolt	HH1/2X2.25	8

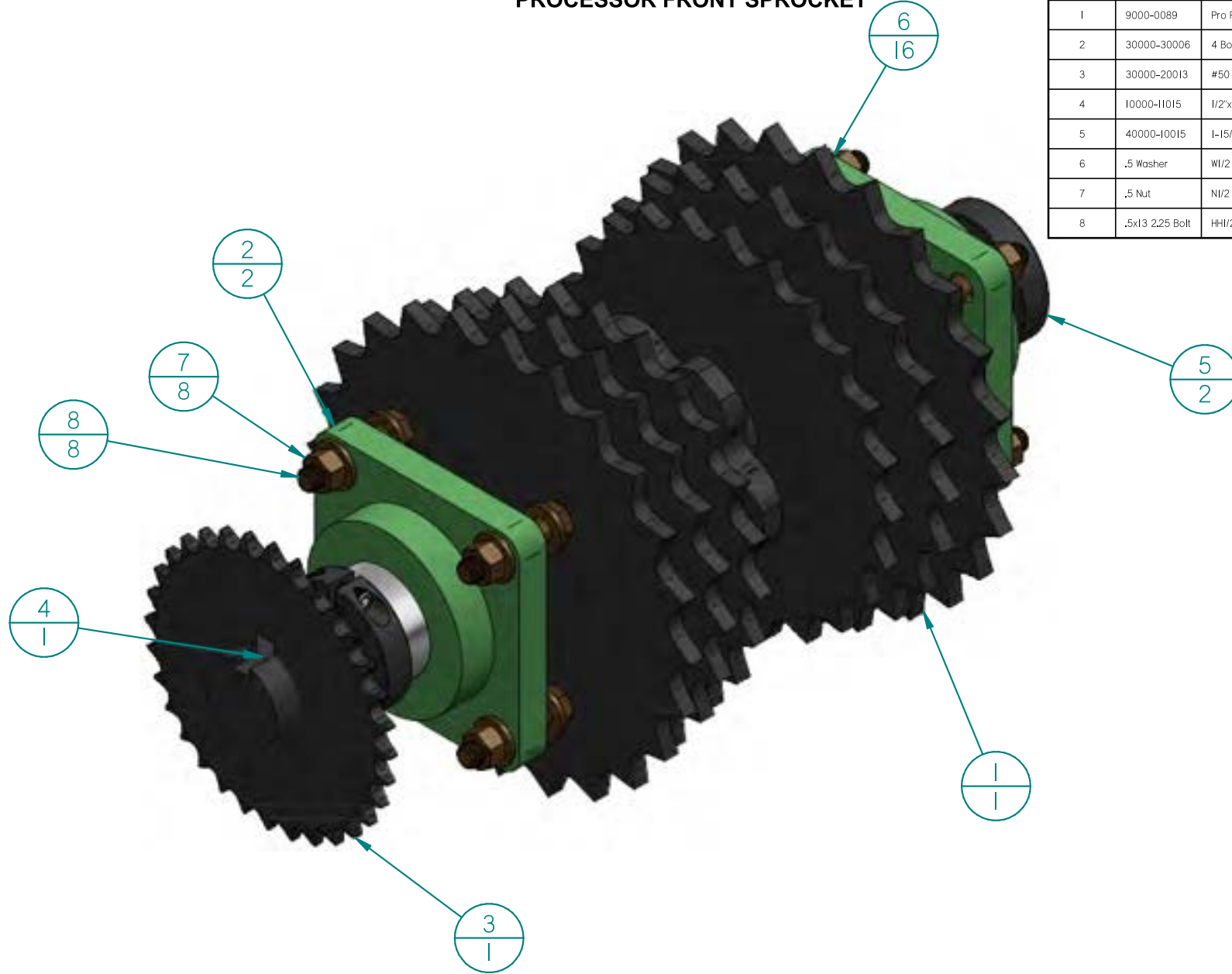

## PROCESSOR FEED TROUGH SPROCKET COVER

Item No	Part No	Part Name	Qty
1	9000-0232	Pro HD FT Sprocket Cover 9-12-23	1
2	W1/4	W1/4	4
3	HH1/4xL25	1/4"X1-1/4" Bolt	4

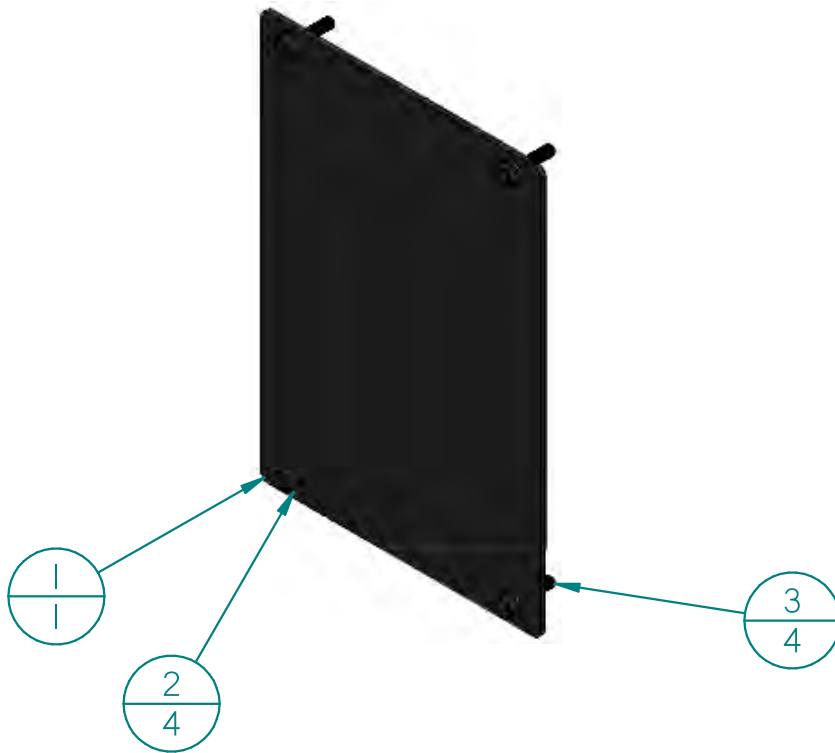

**PROCESSOR TROUGH ROLLER**

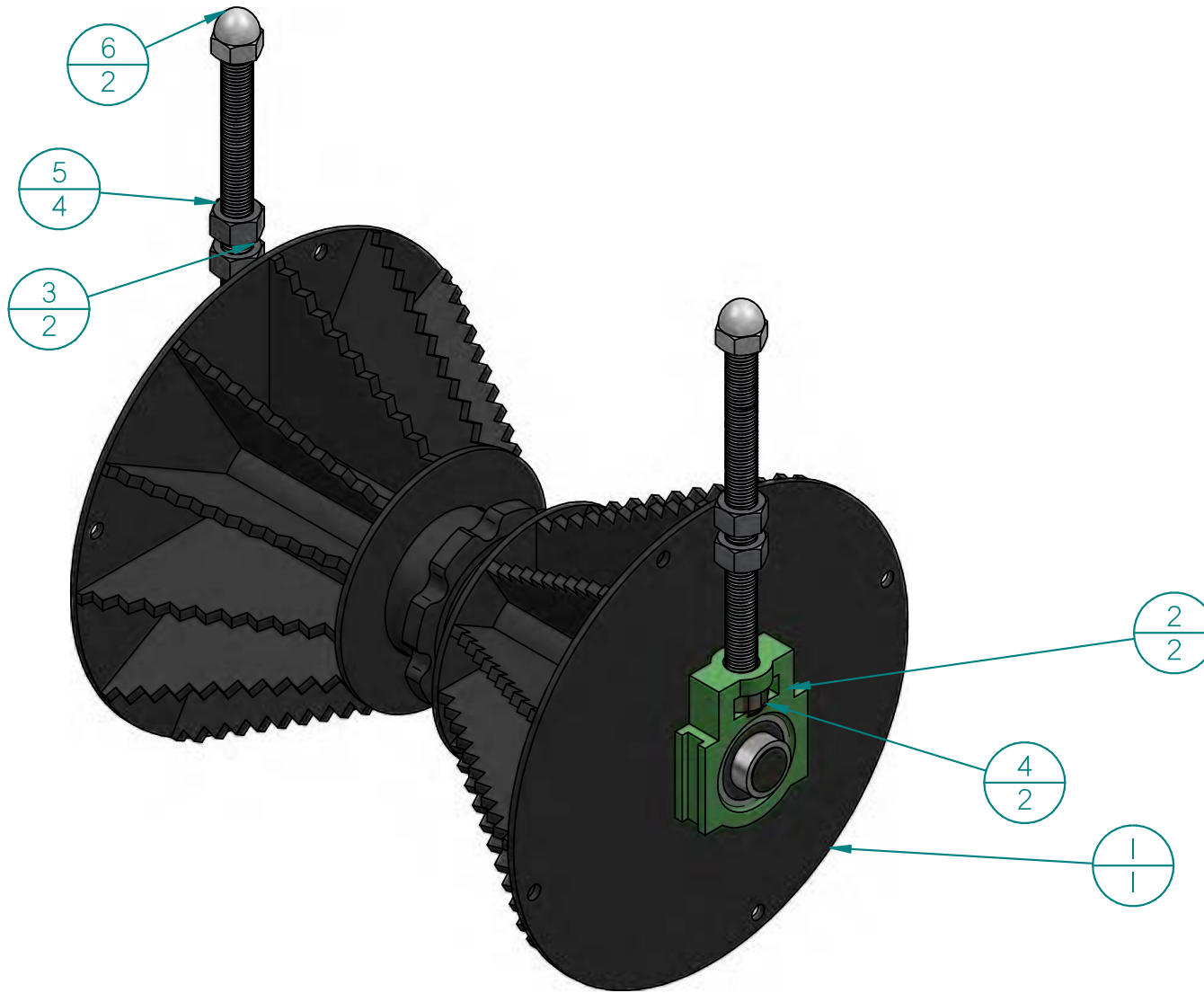

Item No	Part No	Part Name	Qty
1	9000-0091	Pro Trough Roller Reinforced	1
2	30000-30003	1-1/2 Take Up UCT 208 Bearing	2
3	9000-0001	Pro Feed Trough Tensioner Bolt	2
4	1x8 Lock Nut	NNI	2
5	1x8 Nut	1x8 Nut	4
6	1 Cap Nut	1 Cap Nut	2



## PROCESSOR LIVE DECK MOTOR CHAIN

Item No	Part No	Part Name	Qty
1	Use: 30000-10000 x 0,4 units for Pro HD and Pro MP live deck chain	#80 Chain	1
2	30000-10006	#80 Master Link	1

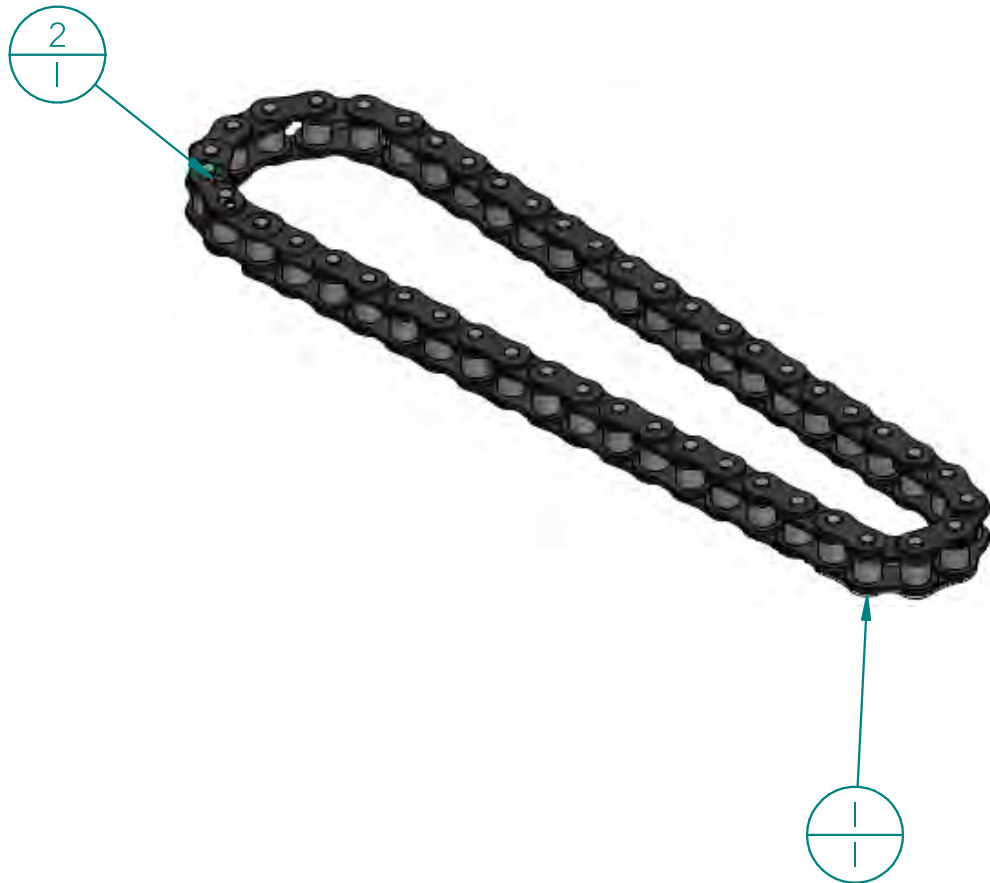

**PROCESSOR FEED TROUGH 50 CHAIN**

Item No	Part No	Part Name	Qty
1	30000-10002	#50 Chain	1
2	30000-10011	#50 Chain Half Link	1
3	30000-10010	#50 Master Link	1



### PROCESSOR FEED TROUGH CHAIN WR78

Item No	Part No	Part Name	Qty
1	9000-0064	Pro FT Chain luse 33,7 ft per machinel	3,37
2	30000-20007	WR78 Chain Master Link	1
3	30000-20008	WR78 Chain Pin	1

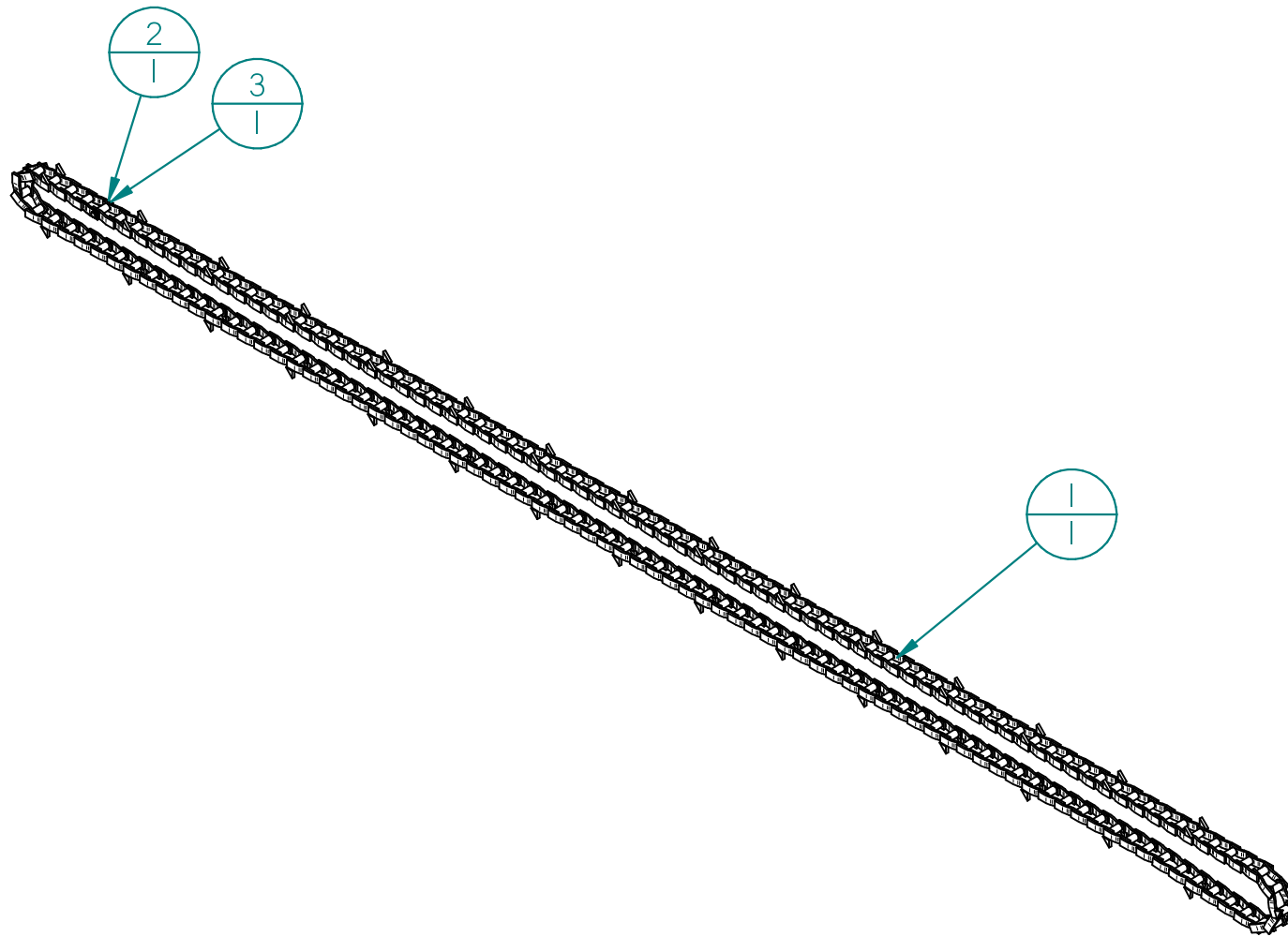

**PRO-MP, MP X, MP XL 3 STRAND LIVE DECK**

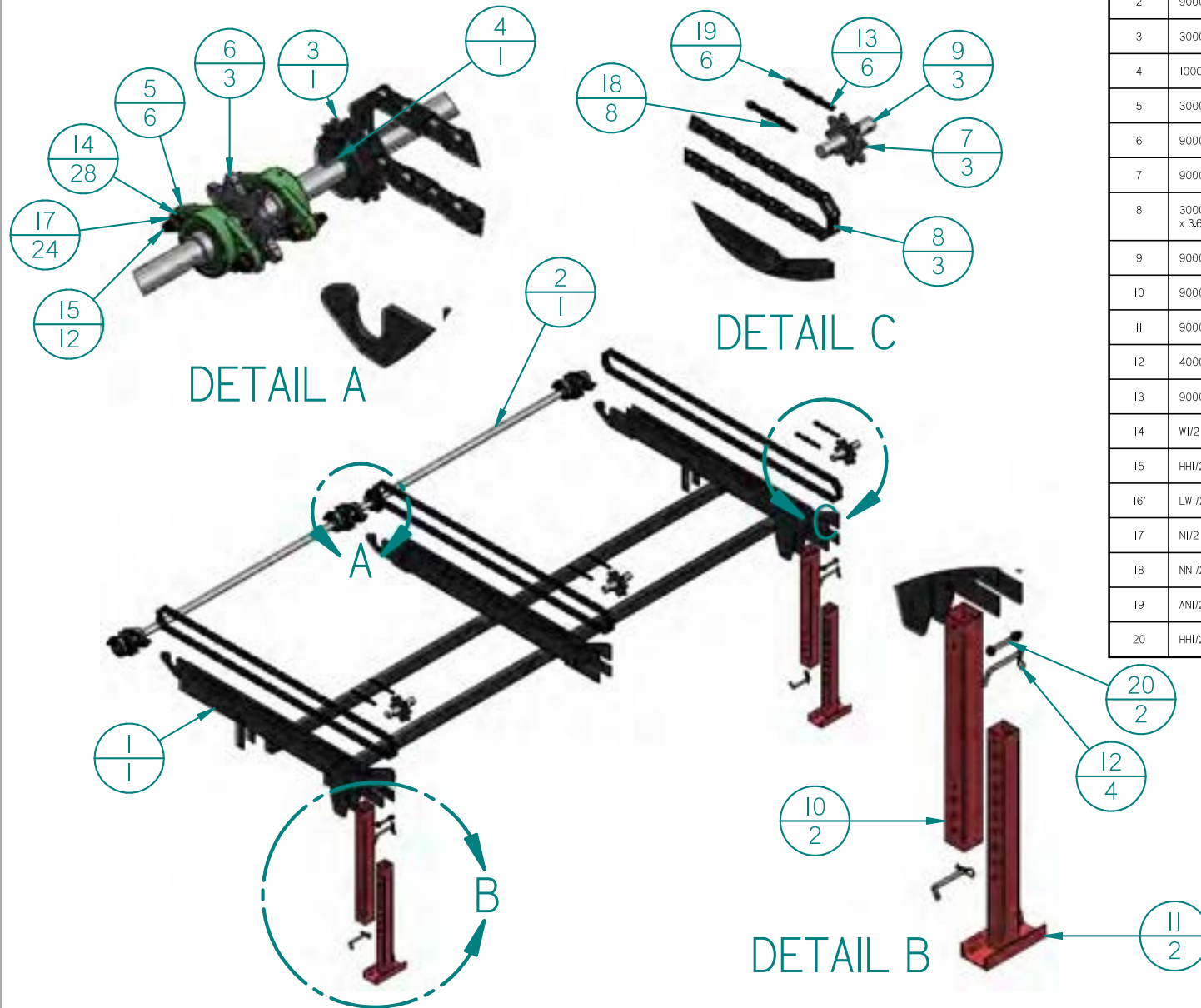

Item No	Part No	Part Name	Qty
1	9000-0211	Pro MP Live Deck 6-I-23	1
2	9000-0229	Pro HD LD Shaft for Split Taper	1
3	30000-20001	15 Teeth #80 Sprocket 1.5"	1
4	10000-11014	3/8"x1.25" Key	1
5	30000-30002	2 Bolt 1-1/2 Flange Bearing	6
6	9000-0221	Split Tapered Drive Sprocket Assembly	3
7	9000-0222	Split Tapered Idler Sprocket Assembly	3
8	30000-30013 x 3.6	C2082 Chain, roughly 36 ft total for MP Live Deck	3
9	9000-0041	Pro LD Idler Shaft	3
10	9000-0045	Pro LD Outer Leg	2
11	9000-0044	Pro Live Deck Inner Leg	2
12	40000-10006	Pull Pin 1/2" x 4" Usable	4
13	9000-0036	Live Deck Tension Bolt	6
14	WI/2	WI/2	28
15	HHI/2X2,25	HHI/2X2,25	12
16	LWI/2	1/2" Spring Washer	12
17	NI/2	NI/2	24
18	NNI/2	NNI/2	8
19	ANI/2	1/2" Anchor Nut	6
20	HHI/2x4,5	.5x13 4,5 Bolt	2

### PRO-MP, MP X, MP XL LIVE DECK LINKAGE

Item No	Part No	Part Name	Qty
1	258-709	Pro MP LD Lift Rocker 6-6-23	2
2	258-708	Pro MP LD Lift Link 6-6-23	2
3	258-947	Pin 1,25D 6,622UL	4
4	40000-10002	Zn Cotter Pin 3/16" x 1-1/2" L	8

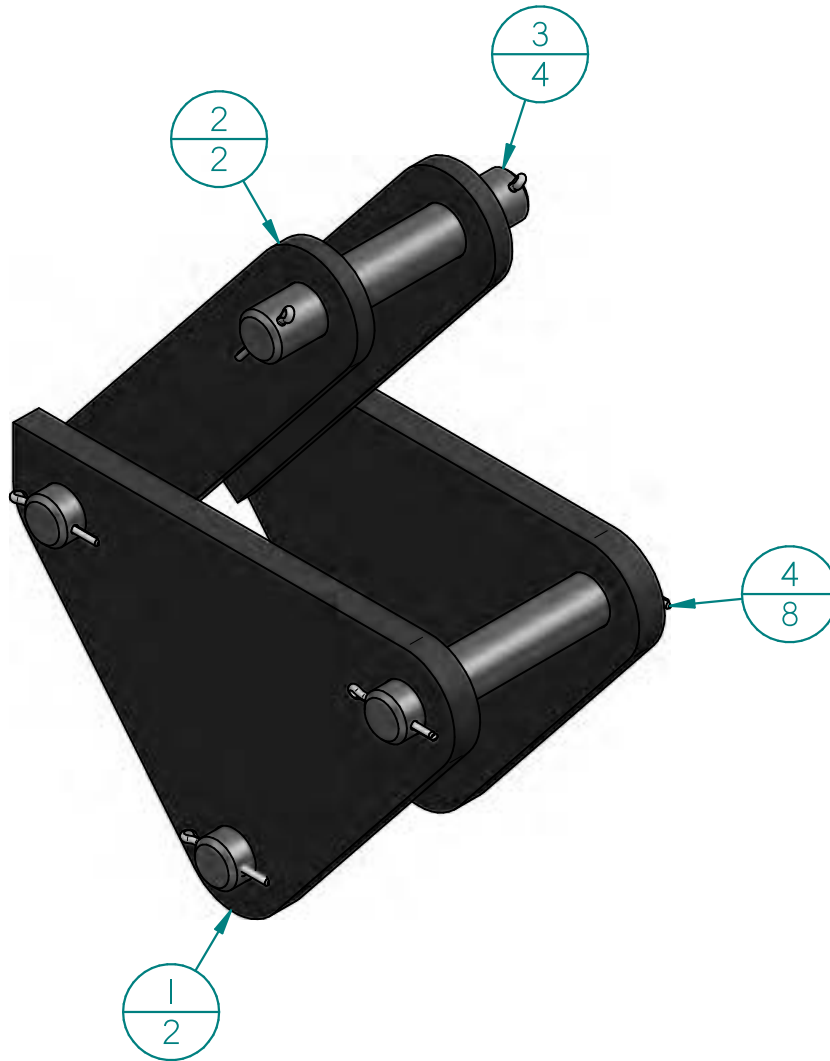

**PROCESSOR LIVE DECK TENSION BLOCK**

Item No	Part No	Part Name	Qty
1	9000-0015	Pro LD Motor Adjuster	2
2	9000-0002	Pro TR Tensioner Rod	2
3	.5 Washer	W1/2	2
4	.5x13 3.5 Bolt	H#1/2X3.5	2
5	.5 Nut	N1/2	6

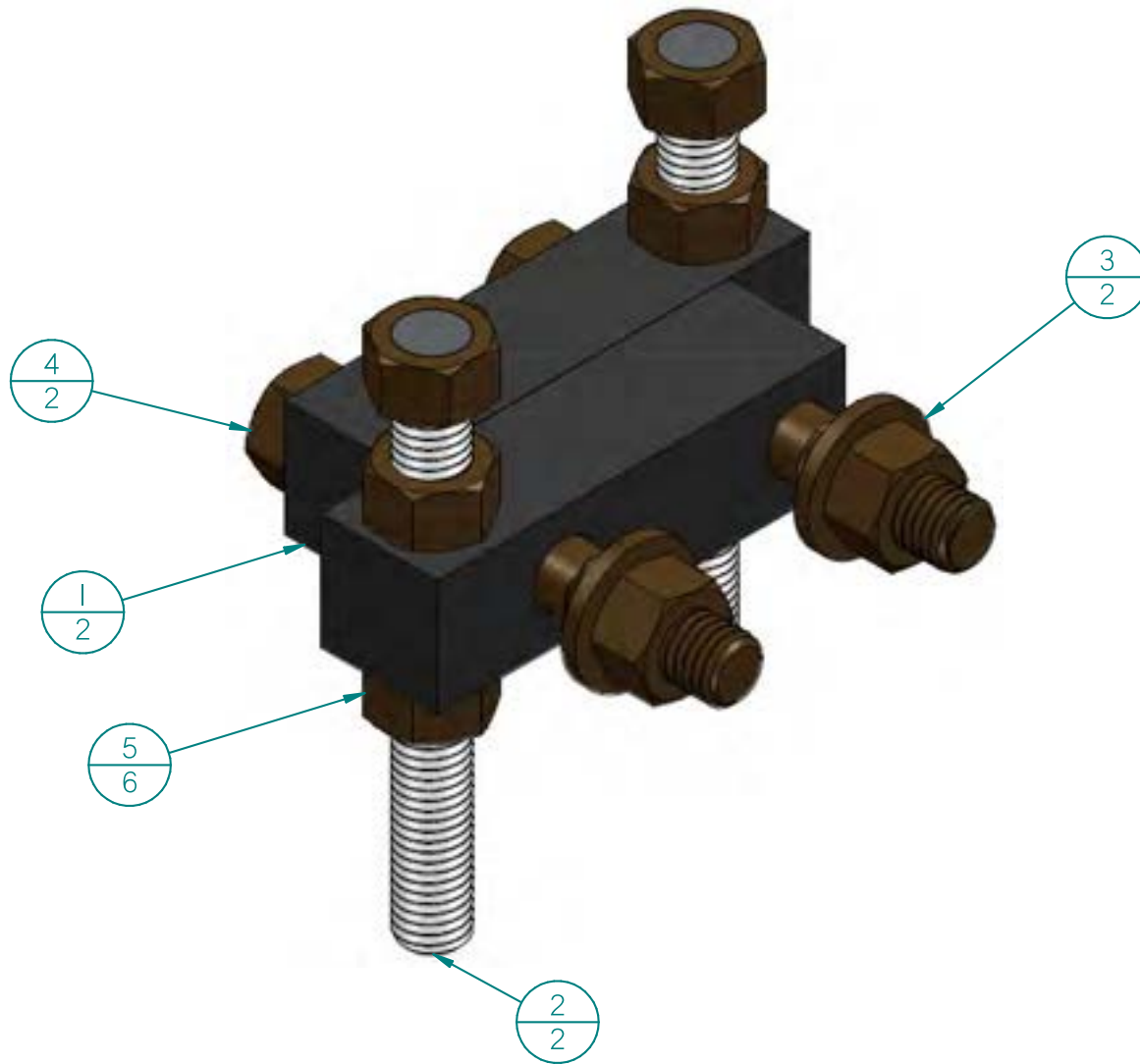

## PROCESSOR LOG FLIPPER

Item No	Part No	Part Name	Qty
1	9000-0018	Pro Log Flipper	2
2	,375 Washer	,375" Washer	8
3	,375x16 I.5 Blot	3/8"x16 I.5 Blot	4
4	,375 Lock Nut	,375 Lock Nut	4

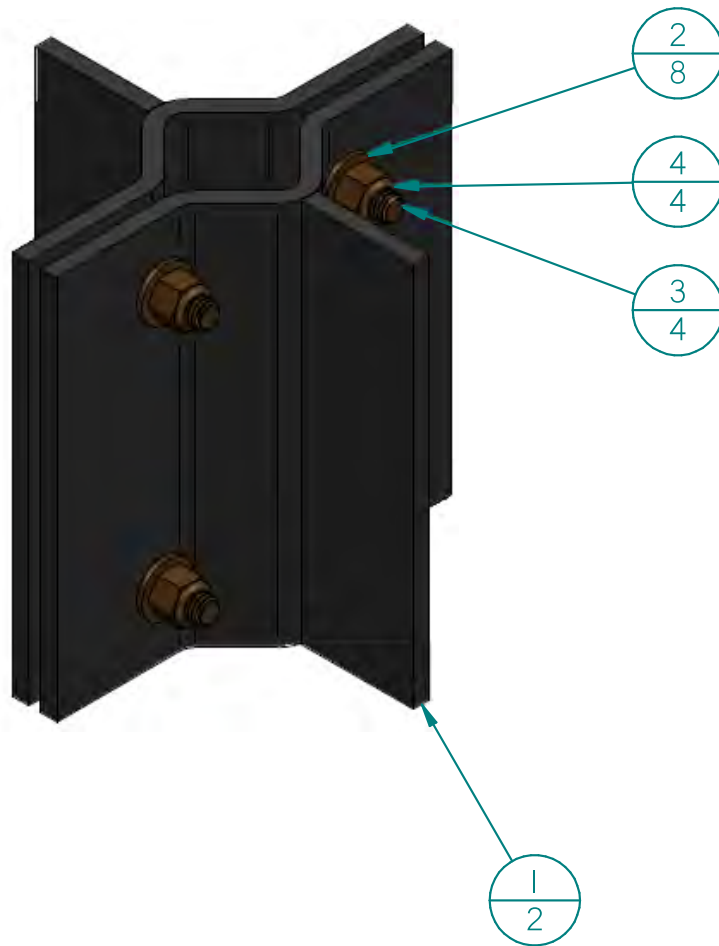



**PROCESSOR STOW BAR**

Item No	Part No	Part Name	Qty
1	9000-0210	Pro MP Stow Bar 6-8-23	1
2	40000-10008	6" x 3/4" Pull Pin	1
3	40000-10005	Pull Pin 1/2" D x 3" UL	1



### PRO-MP, MP X, MP XL TRAY PLATES

Item No	Part No	Part Name	Qty
1	9000-0037	Pro HD Splitter Plate	1
2	9000-0263	Tray Plate Right I-18-24	1
3	FH3/8x2	.375x16 2 Flat Head	6
4	W3/8	W3/8	6
5	N3/8	N3/8	6

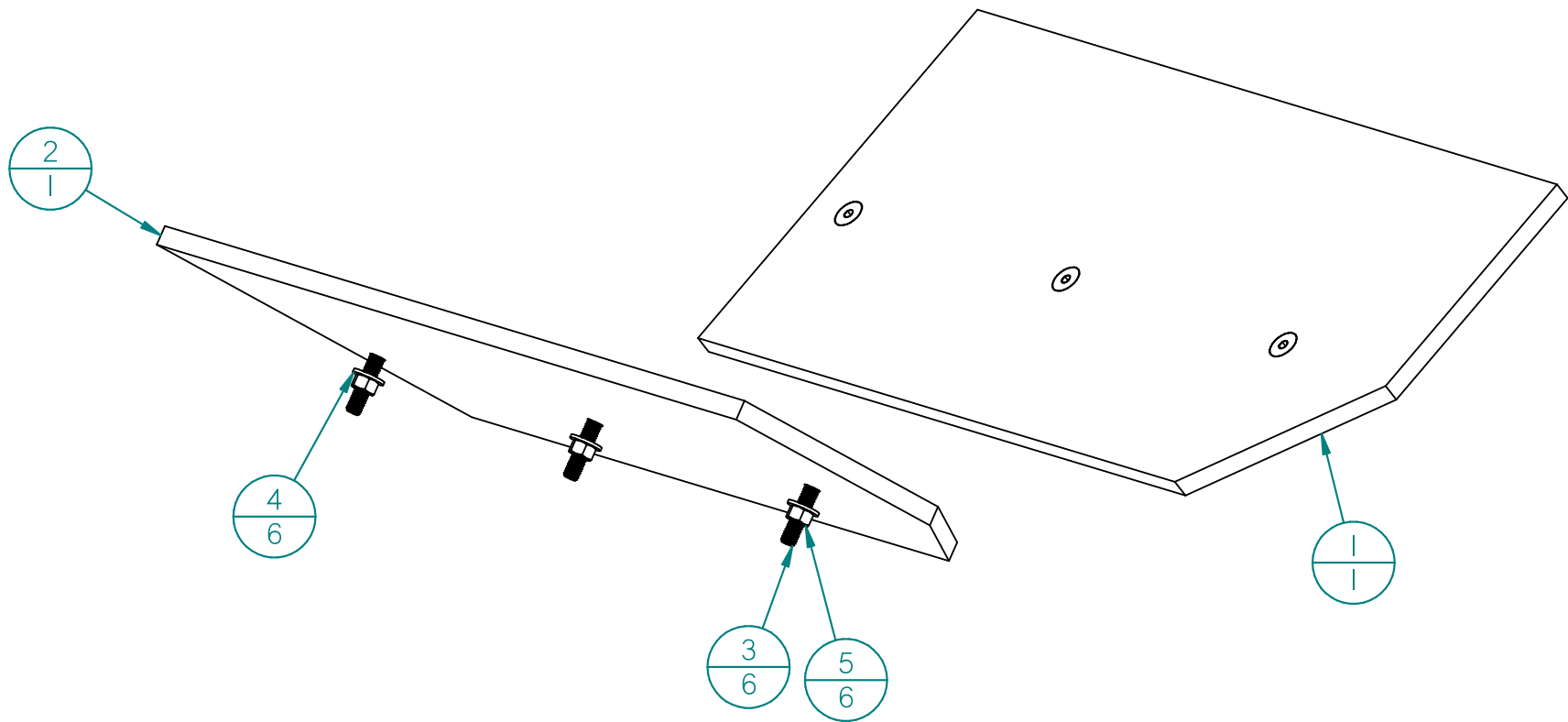

**PRO-MP, MP X, MP XL BAR OIL PUMP**

Item No	Part No	Part Name	Qty
1	60000-20009	Bar Oil Pump	1
2	50000-30008	1/4" Ball Valve - 1/4" NPT M t	1
3	873-200	#4 Hose Barb to #4 NPT M 90	2
4*	W3/8	W3/8	1
5	HH3/8x2	HH3/8X2	1
6	NN3/8	NN3/8	2

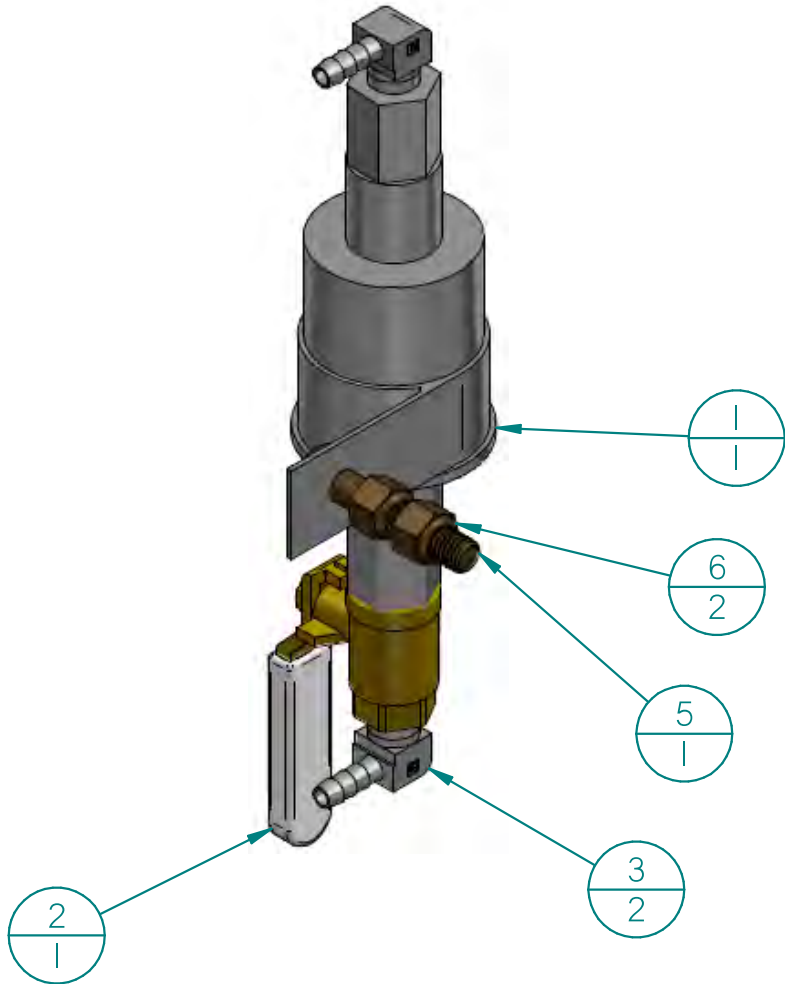

### PRO-MP, MP X, MP XL BAR OIL TANK

Item No	Part No	Part Name	Qty
1	9000-0042	Bar Oil Tank	1
2	50000-30007	1/4" SS Ball Valve	1
3	20000-10004	Breather Filler	1
4	873-100	#4 Barb to #4 NPT M	1
5	873-200	#4 Hose Barb to #4 NPT M 90	2
6	10000-20001	Pro Bar Oil Sight Tube	1
7	833-100	#4 NPT M to #4 NPT M SS (included in 50000-30007)	1
8	SHC10-32x1/2	SHC10-32x1/2 (Comes with breather filler 5-11-23)	6
9	W3/8	W3/8	8
10	HH3/8x1	HH3/8x1	4
11	NN3/8	NN3/8	4

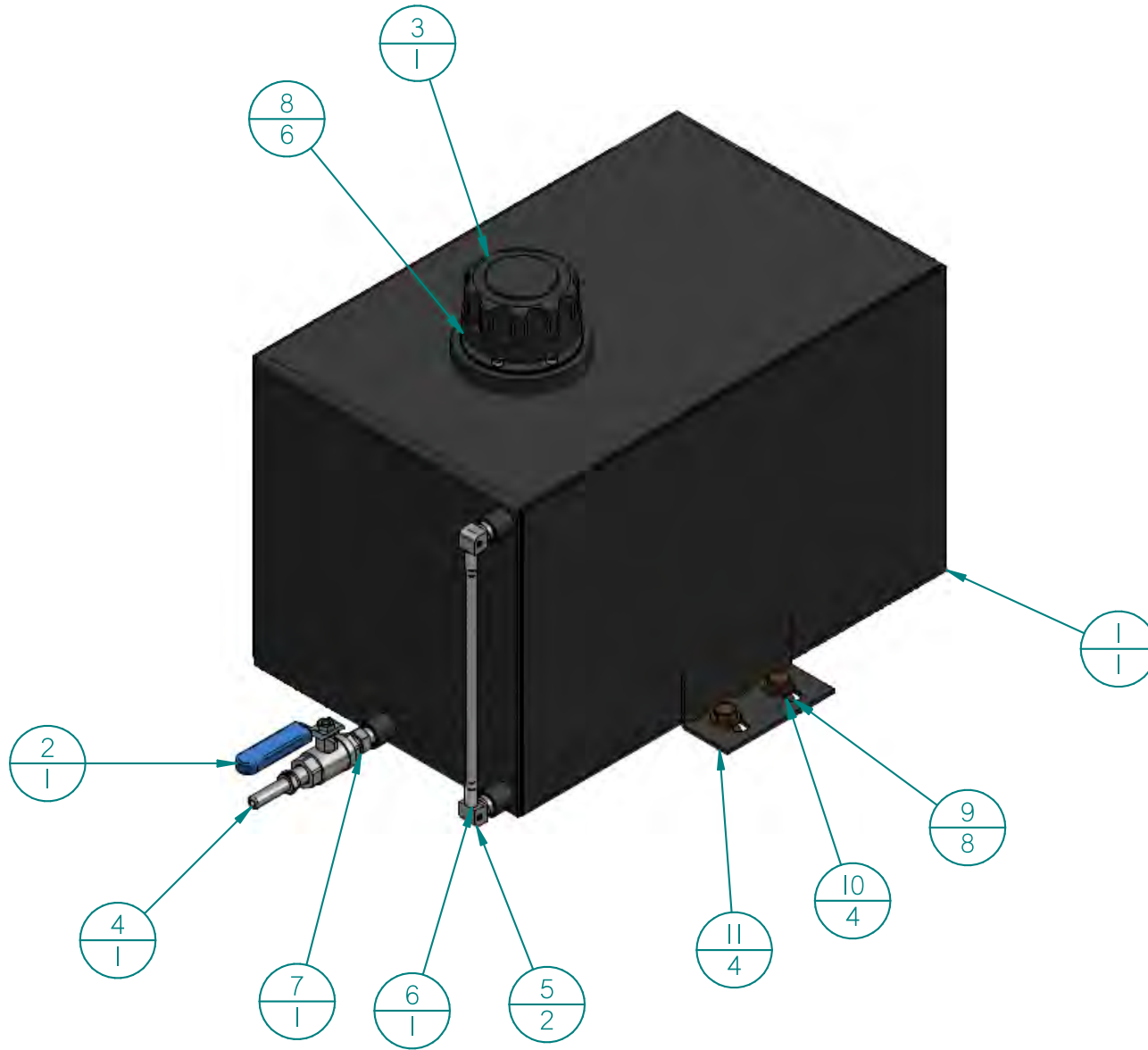

**PRO-MP, MP X, MP XL GAS TANK**

Item No	Part No	Part Name	Qty
1	10000-12005	Flambeau 5 Gallon Tank (doesn't come with 10000-12026 5-11-23, add to BOMS manually)	1
2	WI/4	WI/4	8
3	NNI/4	,25 Lock Nut	4
4	HHI/4x1	HHI/4X1	4
5	FHI/4x1	,25x20 I Flat Head Cutting Screw	2



10000-12005  
Flambeau Tank Kit 9-13-23

**Contains**

1. The flambeau 5 gallon tank
2. The fitting that we used to install ourselves into the flambeau tanks
3. 4 feet of 7/16 fuel line
4. 5 feet of 1/4 inch fuel line
5. 400 cc carbon canister
6. 2 brackets/strips for the flambeau tank
7. 2 cable tie holders
8. 2 cable ties
9. 4 #6 worm clamps
10. 2 #8 worm clamps



### PRO-MP, MP X, MP XL BATTERY

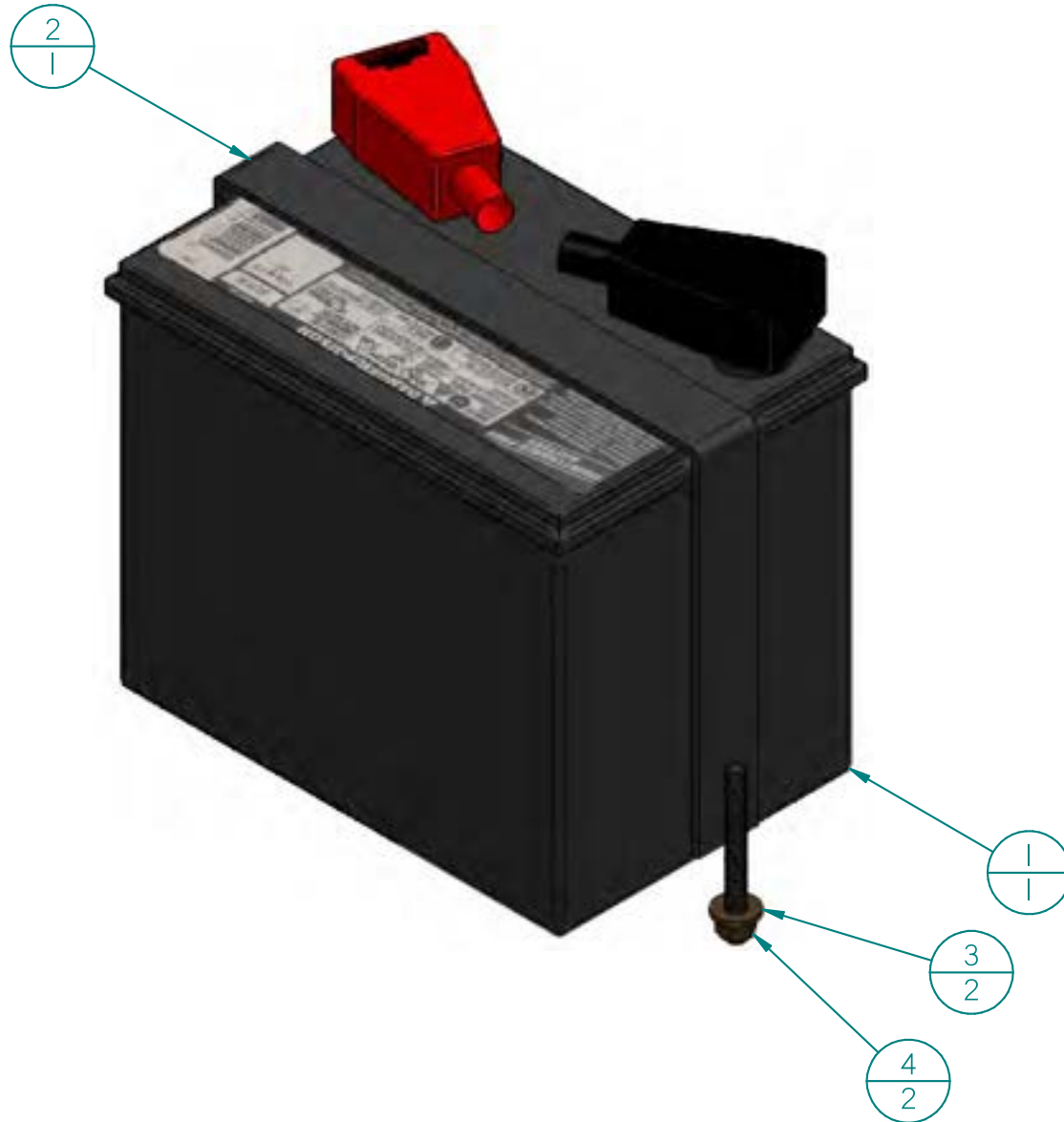

Item No	Part No	Part Name	Qty
1	60000-20015	Battery	1
2	9001-0011	TW Battery Hold Bracket 8in	1
3	W1/4	W1/4	2
4	NN1/4	.25 Lock Nut	2
5*	HH1/4x1	HH1/4X1	2
6*	LWL4	1/4" Lock Washer	2
7*	NI/4	NI/4	2

**PRO-MP, MP X, MP XL HONDA ENGINE GX7000-GX8000**

Check build for which engine to use:  
 GX700=22hp, GX800=25hp (use this page)  
 ECH980=38hp (use other page)

if GX800 has  $\varnothing 1.4375$ " shaft, use  
 Honda bellhousing 9000-0277  
 and couplers from ECH980 page

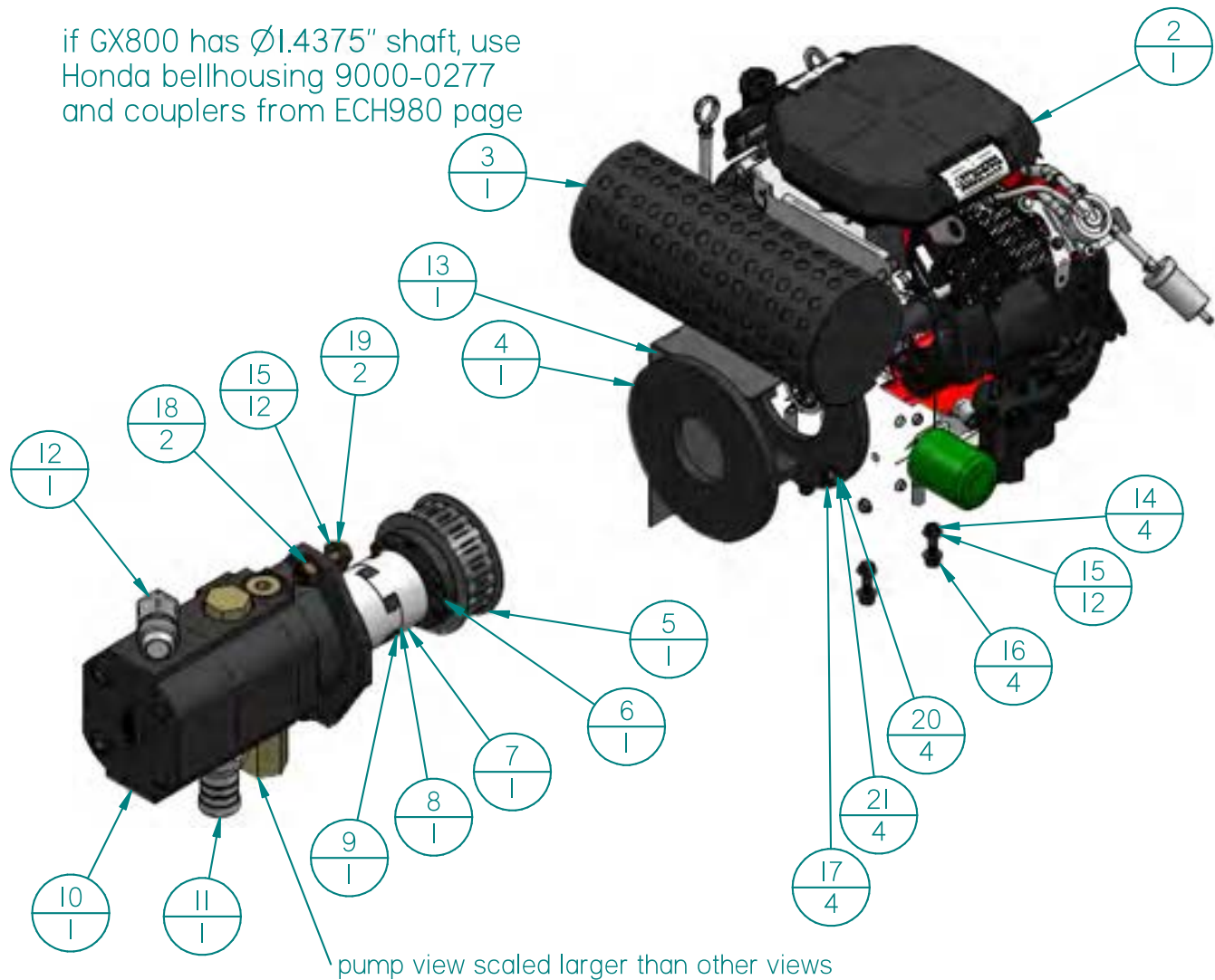

Item No	Part No	Part Name	Qty
1*	70000-00000	GX 700 Engine	1
2	256-134	GX 800 Engine	1
3	70000-00023	Muffler for GX630 Left Side	1
4	9000-0258	Bell Housing Honda	1
5	30000-30018	Timing Belt Pulley 1" Belt Width, H Series Quick-Disconnect, 3.42" OD	1
6	30000-30020	Quick-Disconnect Bushing SH Style, for 1-1/8" Shaft Diameter	1
7	10000-11009	L-095 x 11/25 Jaw Coupler	1
8	10000-11004	L-095 5/8" Jaw Coupler	1
9	10000-11008	Hytel L-095 Spider	1
10	50000-20001	22 GPM Pump	1
11	873-165	#20 Hose Barb to #16 NPT M	1
12	813-244	#12 JIC M to #12 NPT M 90	1
13	9000-0243	Pro MP BellHousing Cover	1
14	HH3/8x1,75	.375 - 16 - 1,75 BOLT	4
15	W3/8	W3/8	12
16	NN3/8	NN3/8	4
17	HH7/16x1,5FT	.4375x1,5 Bolt Fully Threaded	4
18	N3/8	N3/8	2
19	HH3/8x1,5	HH3/8x1,5	2
20	W7/16	W7/16	4
21	LW7/16	7/16 Spring Washer	4

## PRO-MP, MP X, MP XL ENGINE ECH980

Check build for which engine to use:  
 GX700=22hp, GX800=25hp (use other page)  
 ECH980=38hp (use this page)

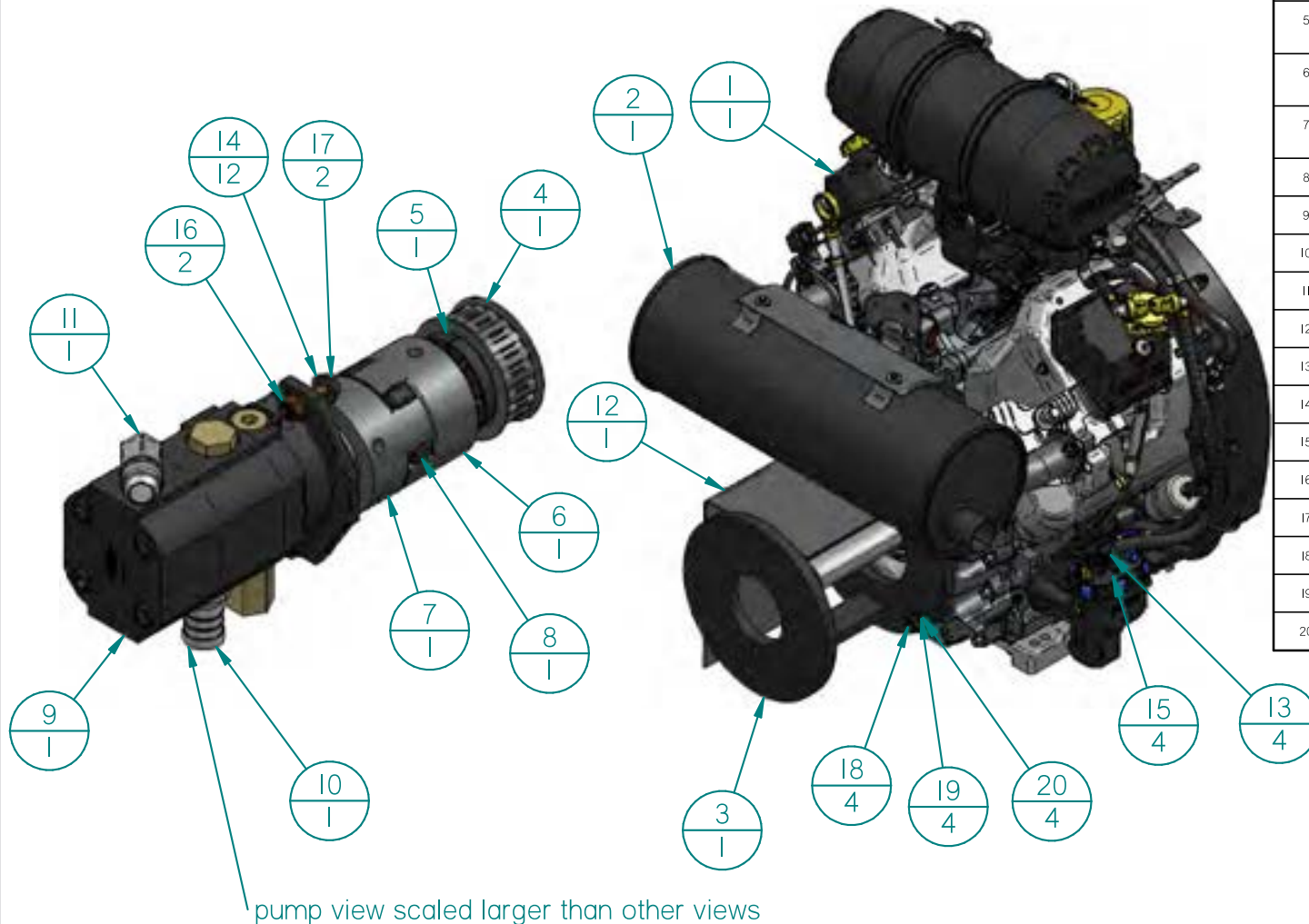

Item No	Part No	Part Name	Qty
1	70000-00024	Kohler 38hp EKECH980-3000 (with engine controls)	1
2	70000-00026	Muffler for Kohler EKECH980 - Exhaust Opposite Starter	1
3	9000-0259	Long Bellhousing Pro MP 12-7-23	1
4	30000-30018	Timing Belt Pulley 1" Belt Width, H Series Quick-Disconnect, 3.42" OD	1
5	30000-30023	Quick-Disconnect Bushing SH Style, for 1-7/16" Shaft Diameter	1
6	10000-11019	L-110 1,4375 Lovejoy Jaw Coupler	1
7	259-005	Trimmed L-110 0,625 Lovejoy Jaw Coupler	1
8	10000-11020	L-110 Hytrel Spider	1
9	50000-20001	22 GPM Pump	1
10	873-165	#20 Hose Barb to #16 NPT M	1
11	813-244	#12 JIC M to #12 NPT M 90	1
12	9000-0248	Pro MP 7.5in Bellhousing Cover	1
13	HH3/8x2	HH3/8X2	4
14	W3/8	W3/8	12
15	NN3/8	NN3/8	4
16	N3/8	N3/8	2
17	HH3/8x1.5	HH3/8X1.5	2
18	HH7/16x1.5FT	.4375x1.4 1.5 Bolt Fully Threaded	4
19	LW7/16	7/16 Spring Washer	4
20	W7/16	W7/16	4



**PRO-MP, MP X, MP XL TRANSFER CASE**

Use this page for 22-2.7 GPM Version  
(no dedicated saw pump)

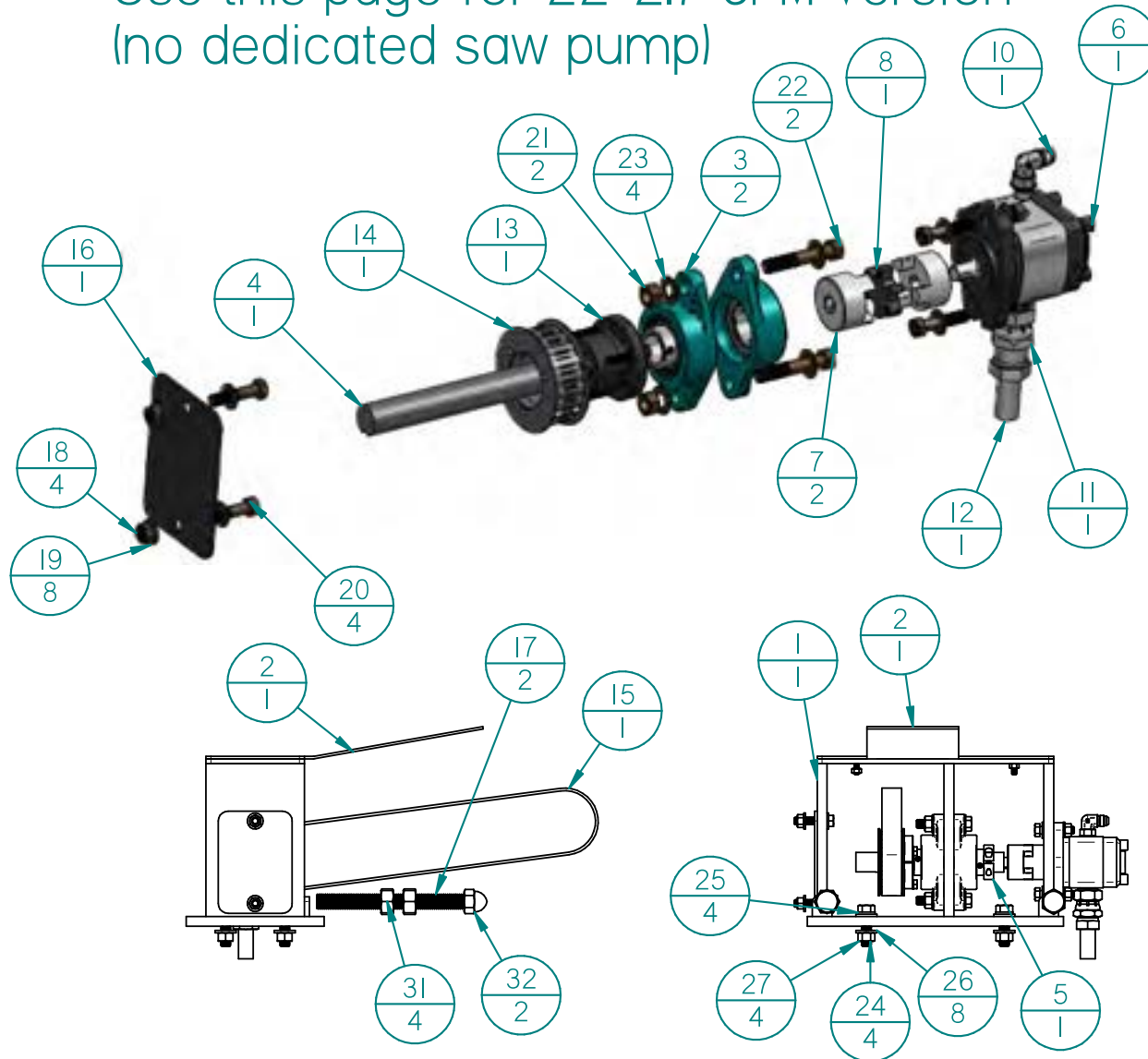

Item No	Part No	Part Name	Qty
1	9000-0233	Transfer Case Plate Weldment	1
2	9000-0244	Pro MP Transfer Case Top Cover	1
3	30000-30021	Mounted Sealed Ball Bearing Flange for 1" Shaft Diameter	2
4	9000-0242	Transfer Case Drive Shaft	1
5	40000-10012	1" C Clamp Collar	1
6	50000-20004	Anfield AP-10-2.7 GPM Pump	1
7	10000-11001	L-075 - 1/2" Jaw Coupler	2
8	10000-11007	L-075 Spider - Buna-N	1
9	10000-11021	1/8"x1" Key	1
10	815-211	#6 JIC M to #6 ORB M	1
11	845-142	#12 NPT F to #8 ORB M	1
12	873-144	#12 Barb to #12 NPT M	1
13	30000-30019	Quick-Disconnect Bushing SH Style, for 1" Shaft Diameter	1
14	30000-30018	Timing Belt Pulley 1" Belt Width, H Series Quick-Disconnect, 3.42" OD	1
15	30000-30022	Timing Belt H Series, Trade No. 420H100US	1
16	9000-0241	Transfer Case Cover No 18GPM	1
17	9002-0036	8in 3/4-10 threaded rod	2
18	N3/8	N3/8	4
19	W3/8	W3/8	8
20	HH3/8x1.75	.375 - 16 - 1.75 BOLT	4
21	N7/16	7/16" Nut	2
22	HH7/16x2.5	7/16"x1.4 2.5" Bolt	2
23	W7/16	W7/16	4
24	HH1/2x1.75	1/2"x1.3 1.75 Bolt	4
25	LW1/2	1/2" Spring Washer	4
26	W1/2	.5 Washer	8
27	NI/2	NI/2	4
28	HH1/4x.75	HH1/4X3/4	2
29	W1/4	W1/4	2
30	NI/4	NI/4	2
31	N3/4	.75 Nut	4
32	AN3/4	AN3/4	2

## PRO-MP, MP X, MP XL TRANSFER CASE

Use this page for 22-18-2.7 GPM Version

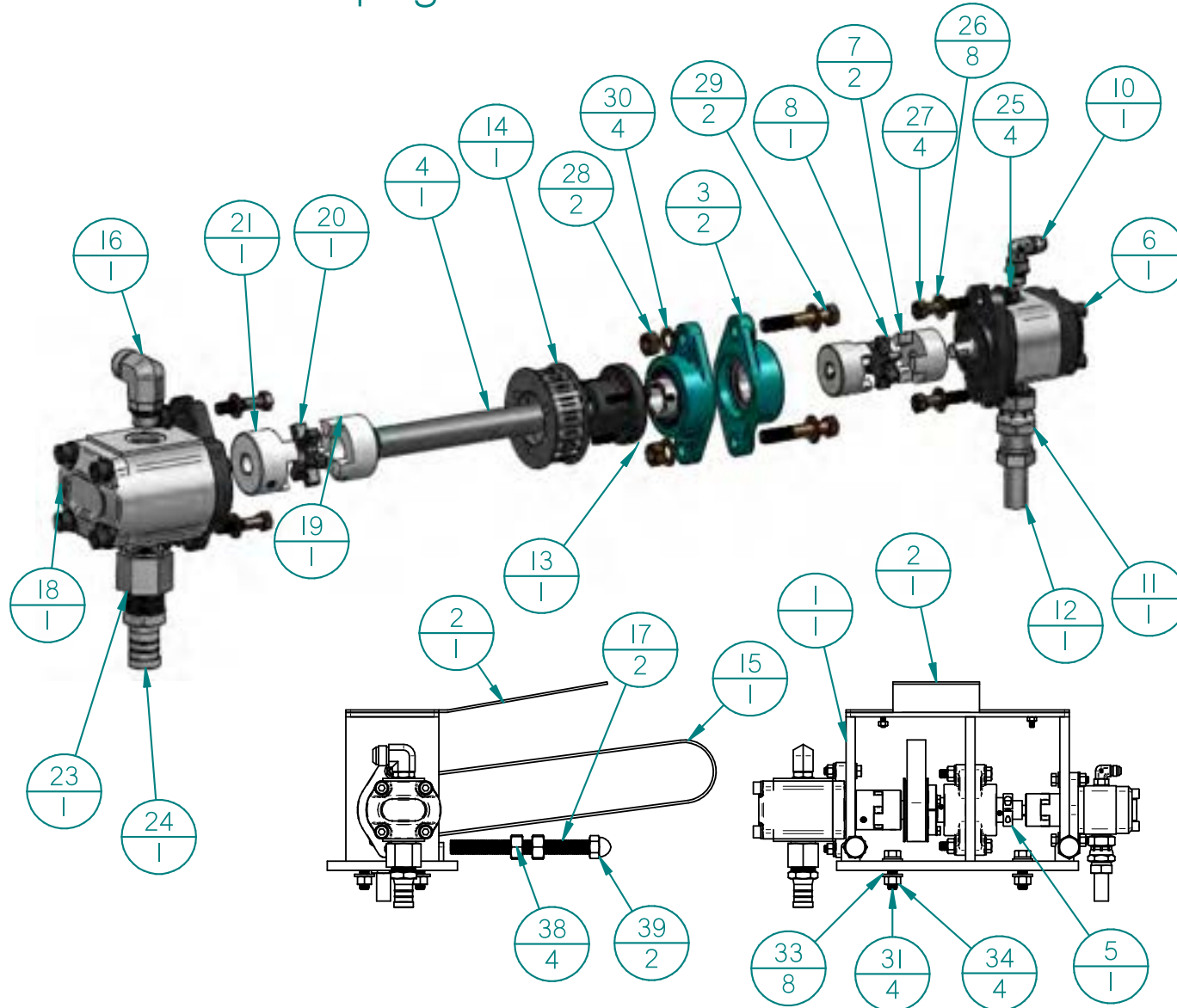

Item No	Part No	Part Name	Qty
1	9000-0233	Transfer Case Plate Weldment	1
2	9000-0244	Pro MP Transfer Case Top Cover	1
3	30000-30021	Mounted Sealed Ball Bearing Flange for 1" Shaft Diameter	2
4	9000-0242	Transfer Case Drive Shaft	1
5	40000-10012	1" C Clamp Collar	1
6	50000-20004	Anfield AP-10-2.7 GPM Pump	1
7	10000-11001	L-075 - 1/2" Jaw Coupler	2
8	10000-11007	L-075 Spider - Buna-N	1
9	10000-11021	1/8"x1" Key	1
10	815-211	#6 JIC M to #8 ORB M	1
11	845-142	#12 NPT F to #8 ORB M	1
12	873-144	#12 Barb to #12 NPT M	1
13	30000-30019	Quick-Disconnect Bushing SH Style, for 1" Shaft Diameter	1
14	30000-30018	Timing Belt Pulley 1" Belt Width, H Series Quick-Disconnect, 3.42" OD	1
15	30000-30022	Timing Belt H Series, Trade No. 42CH100US	1
16	815-243	#12 JIC M to #10 ORB M 90	1
17	9002-0036	8in 3/4-10 threaded rod	2
18	50000-20020	18 GPM Pump GPF2020PA	1
19	10000-11006	L-095 x 1" Jaw Coupler	1
20	10000-11008	Hytel L-095 Spider	1
21	10000-11004	L-095 5/8" Jaw Coupler	1
22	10000-11012	1/4"x1.5" Key	1
23	845-154	#16 NPT F to #12 ORB M	1
24	873-165	#20 Hose Barb to #16 NPT M	1
25	N3/8	N3/8	4
26	W3/8	W3/8	8
27	HH3/8x1.75	.375 - 16 - 1.75 BOLT	4
28	N7/16	7/16" Nut	2
29	HH7/16x2.5	7/16"x14 2.5" Bolt	2
30	W7/16	W7/16	4
31	HH1/2x1.75	1/2"x13 1.75 Bolt	4
32	LW1/2	1/2" Spring Washer	4
33	W1/2	.5 Washer	8
34	NI1/2	NI1/2	4
35	HH1/4x.75	HH1/4x3/4	2
36	W1/4	W1/4	2
37	NI1/4	NI1/4	2
38	N3/4	.75 Nut	4
39	AN3/4	AN3/4	2

**PRO-MP, MP X, MP XL TRANSFER CASE**

Use this page for 22-18-5.8 GPM Version

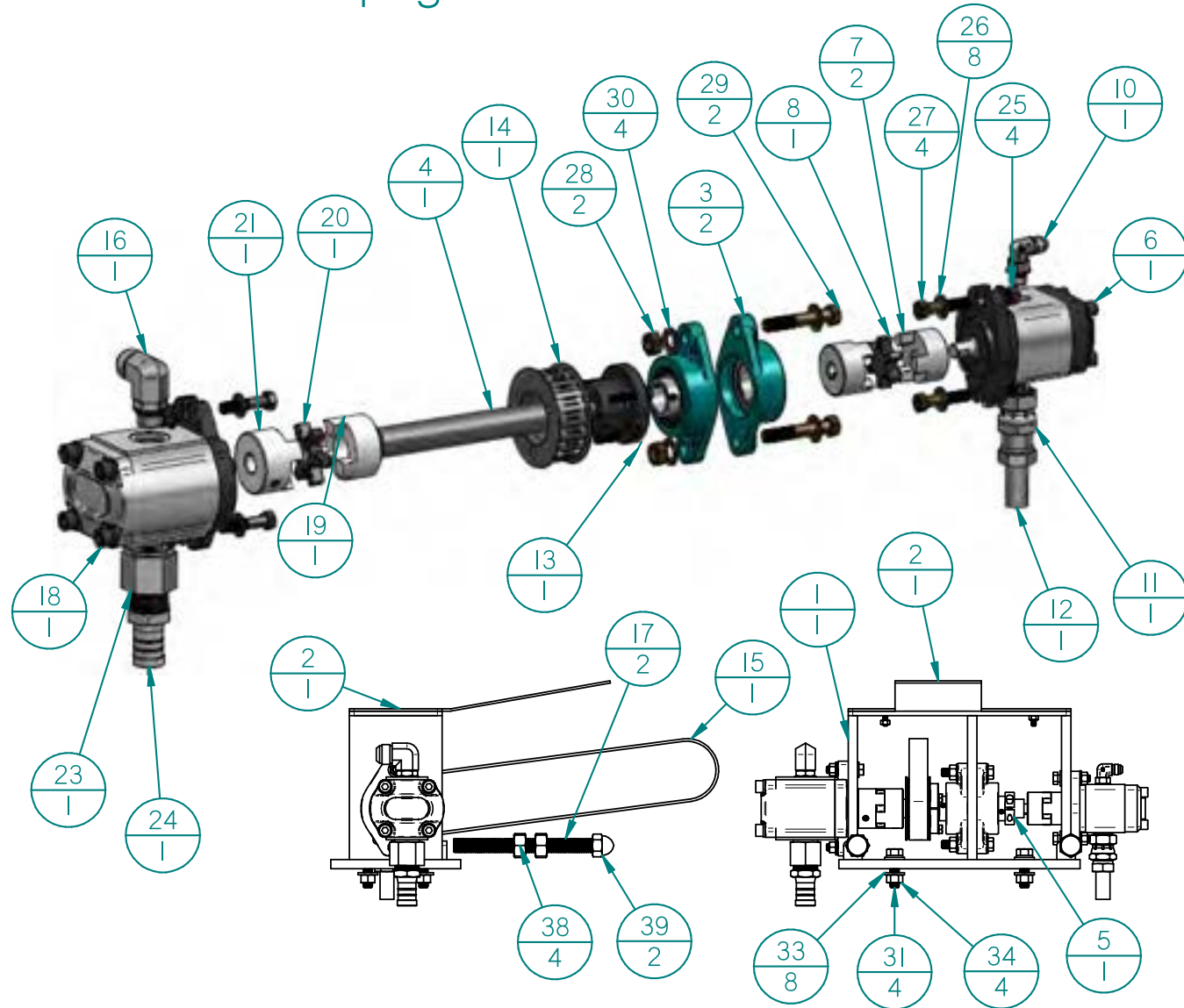

Item No	Part No	Part Name	Qty
1	9000-0233	Transfer Case Plate Weldment	1
2	9000-0244	Pro MP Transfer Case Top Cover	1
3	30000-30021	Mounted Sealed Ball Bearing Flange for 1" Shaft Diameter	2
4	9000-0242	Transfer Case Drive Shaft	1
5	40000-10012	1" C Clamp Collar	1
6	50000-20021	5.8 GPM Pump GPF106IPC	1
7	10000-11001	L-075 - 1/2" Jaw Coupler	2
8	10000-11007	L-075 Spider - Buna-N	1
9	10000-11021	1/8"x1" Key	1
10	815-211	#6 JIC M to #6 ORB M	1
11	845-142	#12 NPT F to #8 ORB M	1
12	873-144	#12 Barb to #12 NPT M	1
13	30000-30019	Quick-Disconnect Bushing SH Style, for 1" Shaft Diameter	1
14	30000-30018	Timing Belt Pulley 1" Belt Width, H Series Quick-Disconnect, 3.42" OD	1
15	30000-30022	Timing Belt H Series, Trade No. 420H100US	1
16	815-243	#12 JIC M to #10 ORB M 90	1
17	9002-0036	8in 3/4-10 threaded rod	2
18	50000-20020	18 GPM Pump GPF2020PA	1
19	10000-11006	L-095 x 1" Jaw Coupler	1
20	10000-11008	Hytel L-095 Spider	1
21	10000-11004	L-095 5/8" Jaw Coupler	1
22	10000-11012	1/4"x1.5" Key	1
23	845-154	#16 NPT F to #12 ORB M	1
24	873-165	#20 Hose Barb to #16 NPT M	1
25	N3/8	N3/8	4
26	W3/8	W3/8	8
27	HH3/8x1.75	.375 - 16 - 1.75 BOLT	4
28	N7/16	7/16" Nut	2
29	HH7/16x2.5	7/16"x14 2.5" Bolt	2
30	W7/16	W7/16	4
31	HH1/2x1.75	1/2"x13 1.75 Bolt	4
32	LW1/2	1/2" Spring Washer	4
33	W1/2	.5 Washer	8
34	N1/2	N1/2	4
35	HH1/4x.75	HH1/4x3/4	2
36	W1/4	W1/4	2
37	N1/4	N1/4	2
38	N3/4	.75 Nut	4
39	AN3/4	AN3/4	2

## PRO-MP, MP X, MP XL VALVE STAND PLATE AND BOLTS

Item No	Part No	Part Name	Qty
1	9000-0217	Pro MP Valve Tower Plate 6-19-23	1
2	9000-0000	Pro Valve Stand Tube	4
3	HH1/2x7.5	,5x13 7,5 Bolt	4
4	W1/2	W1/2	8
5	N1/2	N1/2	4
6	LW1/2	1/2" Spring Washer	4

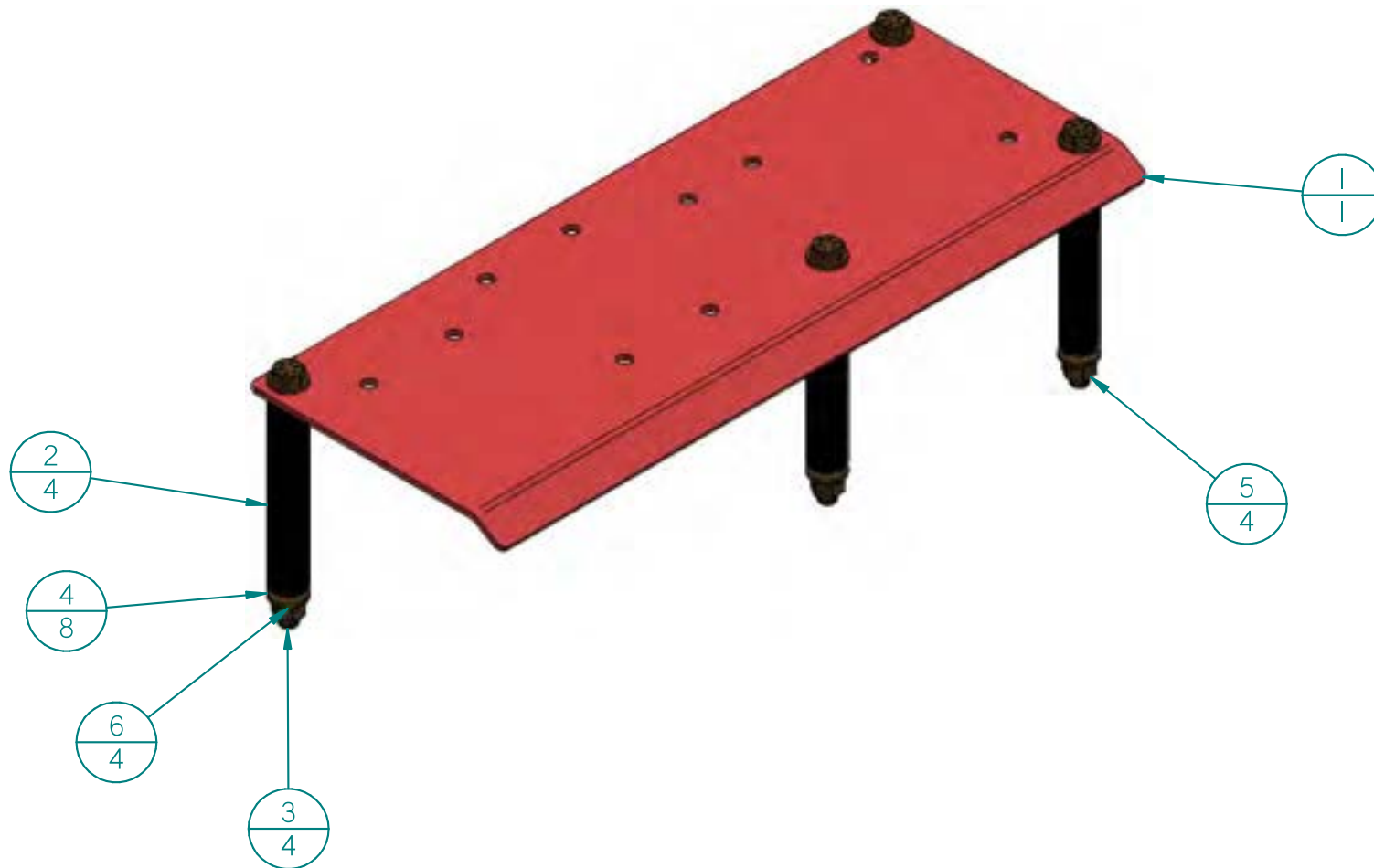

**PRO-MP, MP X, MP XL PRESSURE GAUGES**

Item No	Part No	Part Name	Qty
1	9000-0152	Pro MP Gauge Stand	1
2	20000-20024	5000 PSI Panel Gauge	3
4	814-110	#6 JIC M to #4 NPT F	3

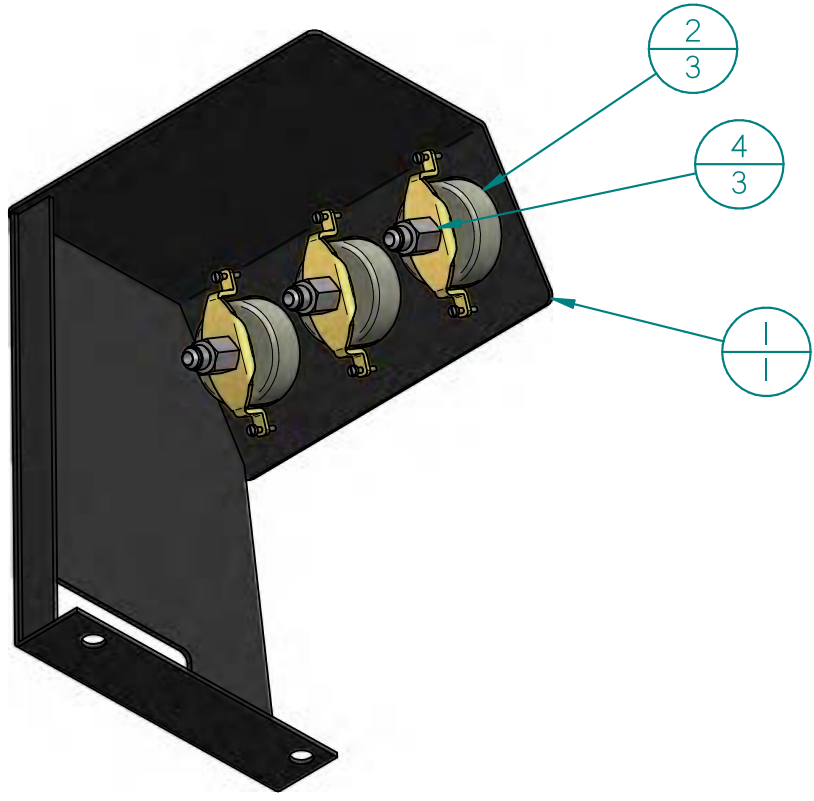

### PRO-MP, MP X, MP XL MANIFOLD

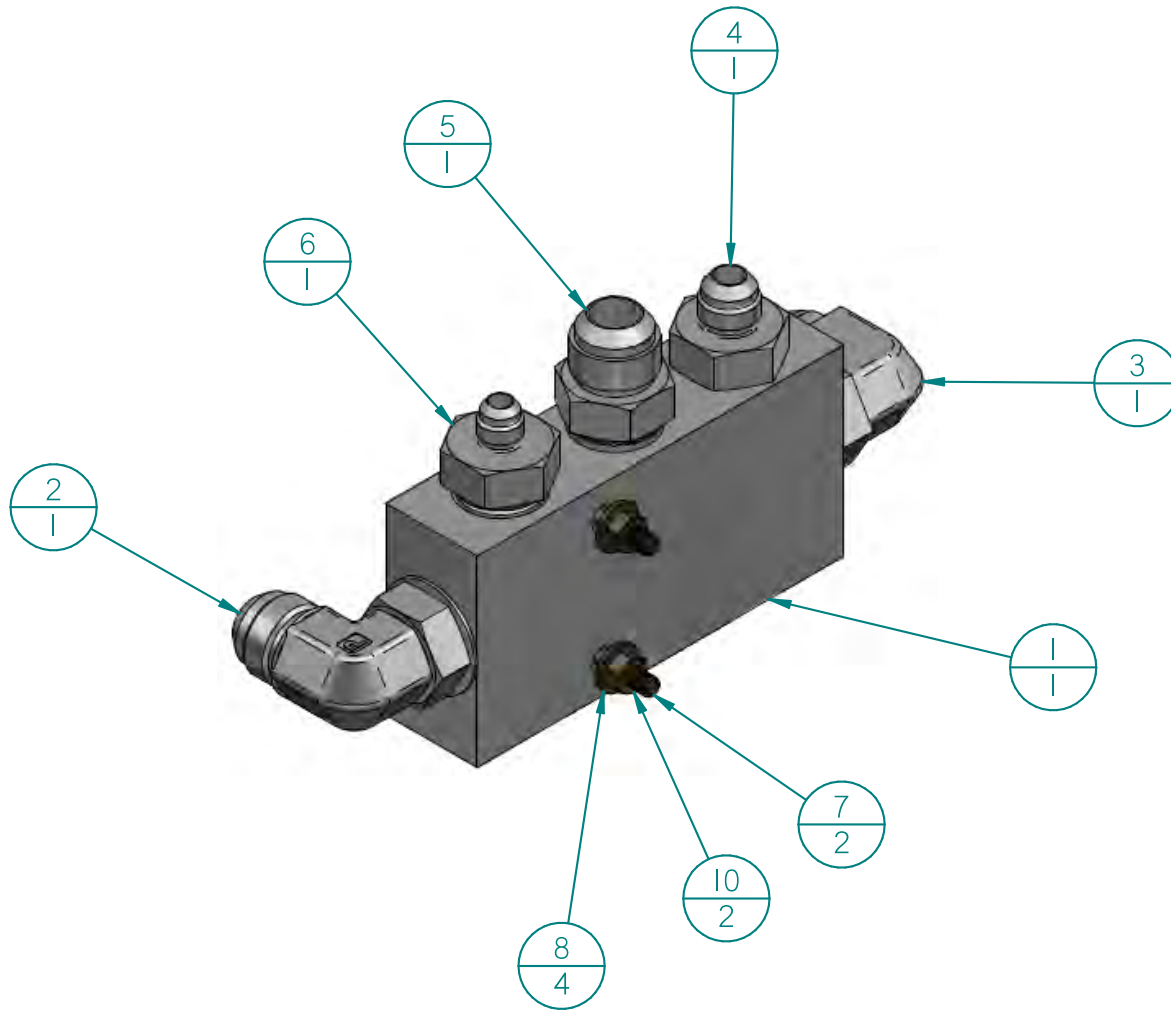

Item No	Part No	Part Name	Qty
1	902-000	Pro HD Manifold	1
2	815-244	#12 JIC M to #12 ORB M 90	1
3	815-224	#8 JIC M to #12 ORB M 90	1
4	815-124	#8 JIC M to #12 ORB M	1
5	815-144	#12 JIC M to #12 ORB M	1
6	815-114	#6 JIC M to #12 ORB M	1
7	HH1/4X2.5	.25x20 2.5 Bolt	2
8	W1/4	W1/4	4
9*	LW1/4	1/4" Lock Washer	2
10	NI/4	NI/4	2

**PRO-MP, MP X, MP XL BOTTOM TWO SPOOL BAR**

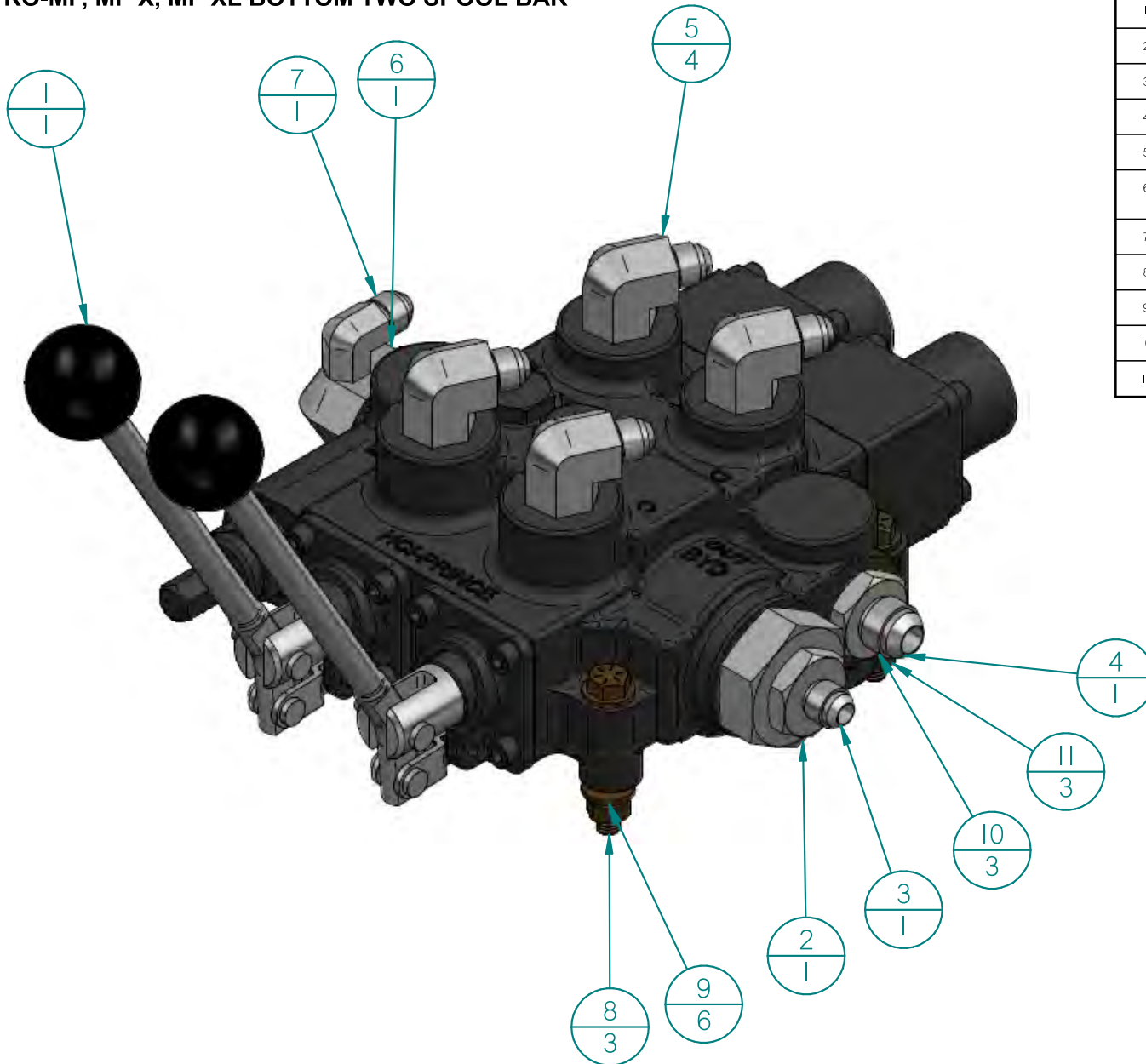

Item No	Part No	Part Name	Qty
1	50000-10002	2 Spool Flat Valve	1
2	800-041	Power Beyond Plug Kit	1
3	813-114	#6 JIC to #12 NPT M	1
4	813-124	#8 JIC M to #12 NPT M	1
5	813-212	#6 JIC M to #8 M NPT 90	4
6	813-214-D	#6 JIC M to #12 NPT M 90 Drilled	1
7	813-210	#6 JIC M to #4 NPT M 90	1
8	HH5/16x2.25	5/16"x18 2.25 Bolt	3
9	W5/16	W5/16	6
10	LW5/16	5/16" Spring Washer	3
11	N5/16	N5/16	3



## PROCESSOR FEED TROUGH SPROCKET COVER

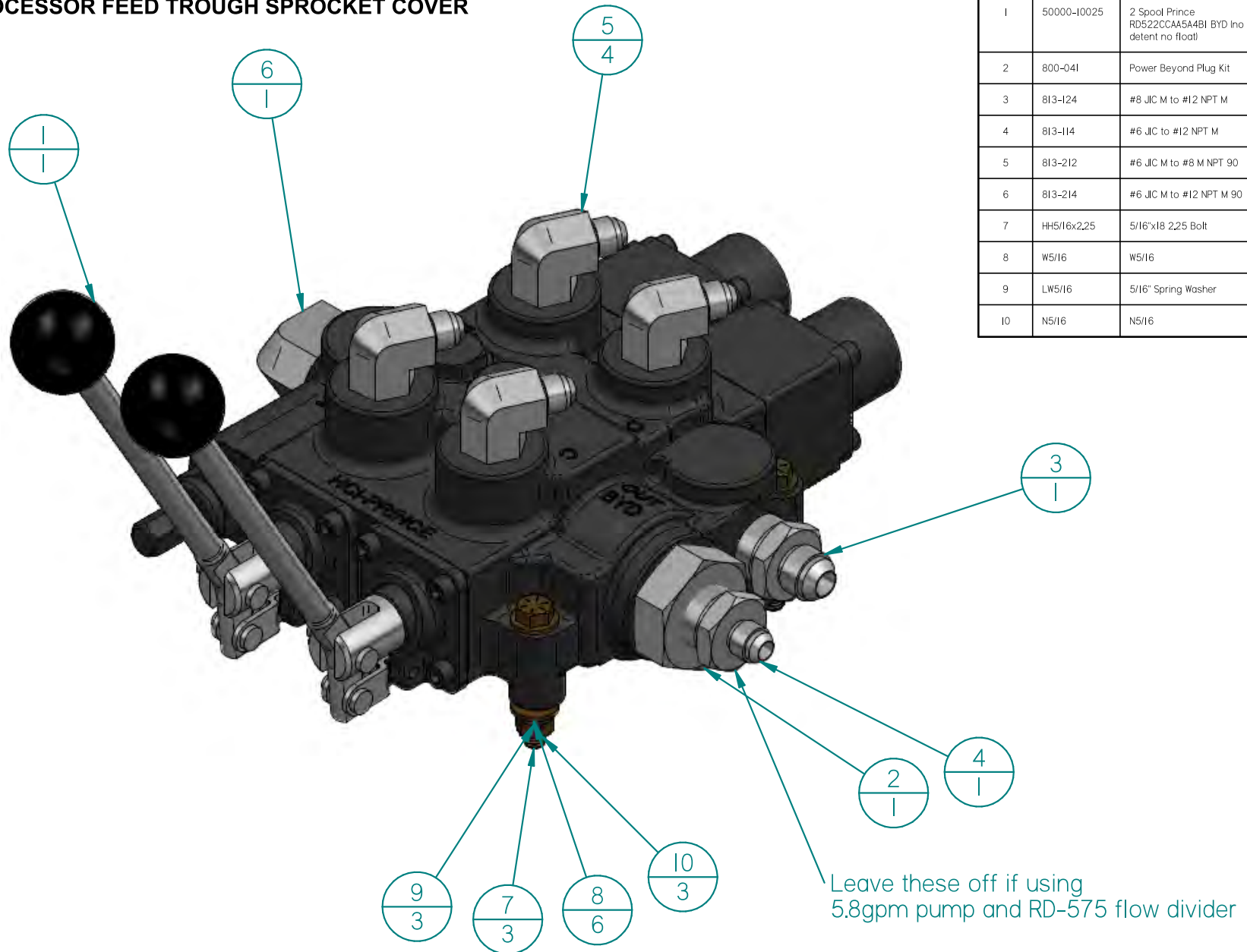

Item No	Part No	Part Name	Qty
1	50000-10025	2 Spool Prince RD522CAA5A4BI BYD lno detent no float!	1
2	800-041	Power Beyond Plug Kit	1
3	813-124	#8 JIC M to #12 NPT M	1
4	813-114	#6 JIC to #12 NPT M	1
5	813-212	#6 JIC M to #8 M NPT 90	4
6	813-214	#6 JIC M to #12 NPT M 90	1
7	HH5/16x2.25	5/16"x18 2.25 Bolt	3
8	W5/16	W5/16	6
9	LW5/16	5/16" Spring Washer	3
10	N5/16	N5/16	3



**PRO-MP, MP X, MP XL TOP TWO SPOOL SAW MOTOR**

Item No	Part No	Part Name	Qty
1	50000-10025	2 Spool Prince RD522CCAA5A4BI BYD lno detent no float)	1
2	813-212	#6 JIC M to #8 M NPT 90	2
3	9000-0003	Pro Saw Switch Mount	1
4	60000-10038	Bar Oil Switch	1
5	813-210	#6 JIC M to #4 NPT M 90	1
6	813-244	#12 JIC M to #12 NPT M 90	1
7	813-244-D	#12 JIC M to #12 NPT M 90	1
8	813-232	#10 JIC M to #8 NPT M 90	1
9	HH5/16x2,25	5/16"x18 2,25 Bolt	3
10	W5/16	W5/16	6
11	LW5/16	5/16" Spring Washer	3
12	N5/16	N5/16	3

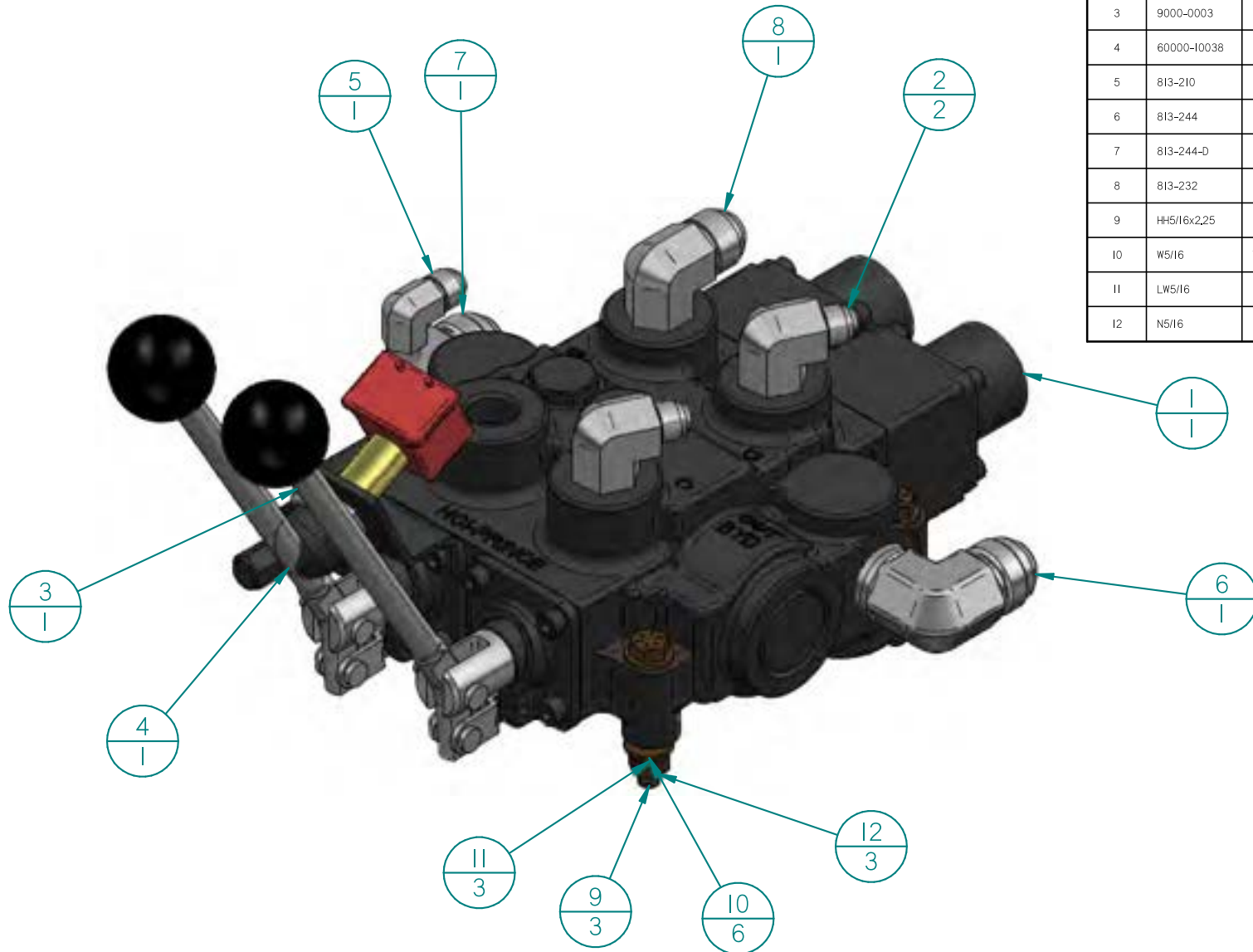

### PRO-MP, MP X, MP XL AUTOCYCLE VALVE

Item No	Part No	Part Name	Qty
1	50000-10016	2 Spool Auto Cycle RD523MME5A	1
2	813-244	#12 JIC M to #12 NPT M 90	3
3	813-254	#16 JIC M to #12 NPT M 90	1
4	813-210	#6 JIC M to #4 NPT M 90	1
5	813-244-D2	#12 JIC M to #12 NPT M 90 Drilled Left Side	1
6	800-041	Power Beyond Plug Kit	1
7	813-144	#12 JIC M to #12 NPT M	1
8	HH5/16x2,25	5/16"x18 2.25 Bolt	3
9	W5/16	W5/16	6
10	LW5/16	5/16" Spring Washer	3
11	N5/16	N5/16	3

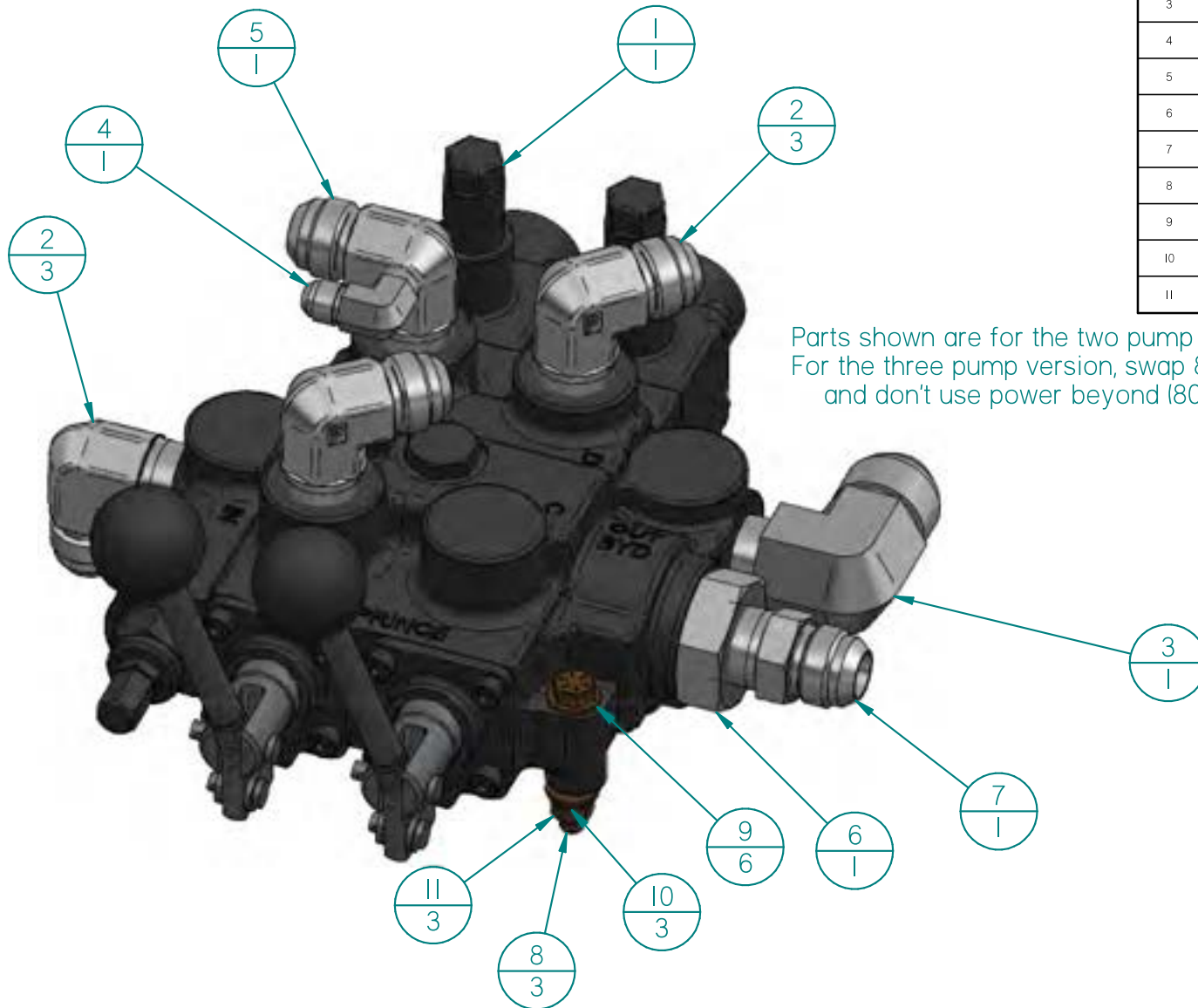

Parts shown are for the two pump version  
 For the three pump version, swap 813-244-D2 with inlet fitting  
 and don't use power beyond (800-041 and 813-144)

**PRO-MP, MP X, MP XL WOLVERINE VALVE**

Item No	Part No	Part Name	Qty
1	50000-10004	MB 2 Spool Valve	1
2	815-212	#6 JIC M to #8 ORB M 90	2
3	815-112	#6 JIC M to #8 ORB M	2
4	W5/16	W5/16	6
5	N5/16	N5/16	3
6	HH5/16x2,5	HH5/16X2,5	3

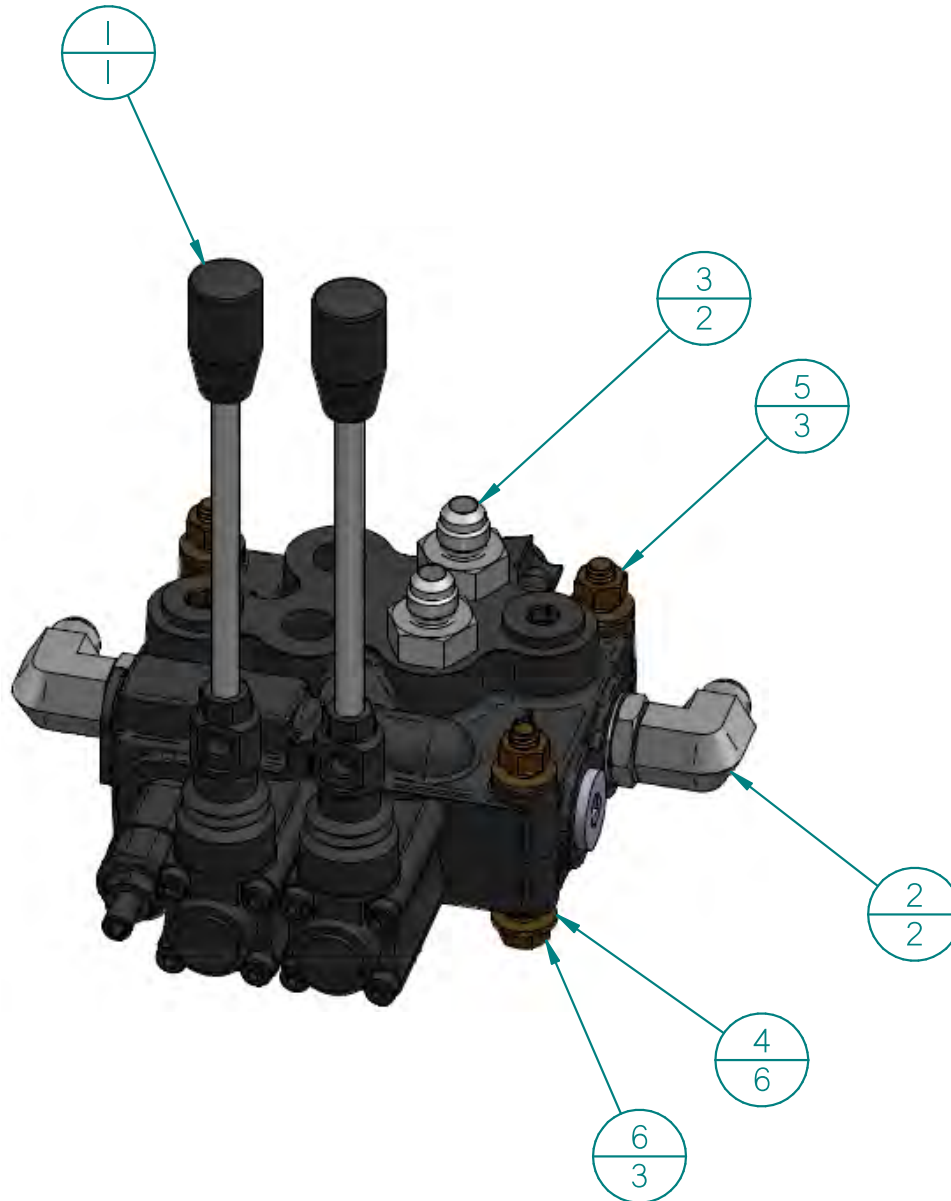

### PRO-MP, MP X, MP XL VALVE GUARD

Item No	Part No	Part Name	Qty
1	9000-0234	Pro Valve Guard 9-20-23	1
2	HH3/8x1	HH3/8x1	3
3	W3/8	W3/8	6
4	N3/8	N3/8	3

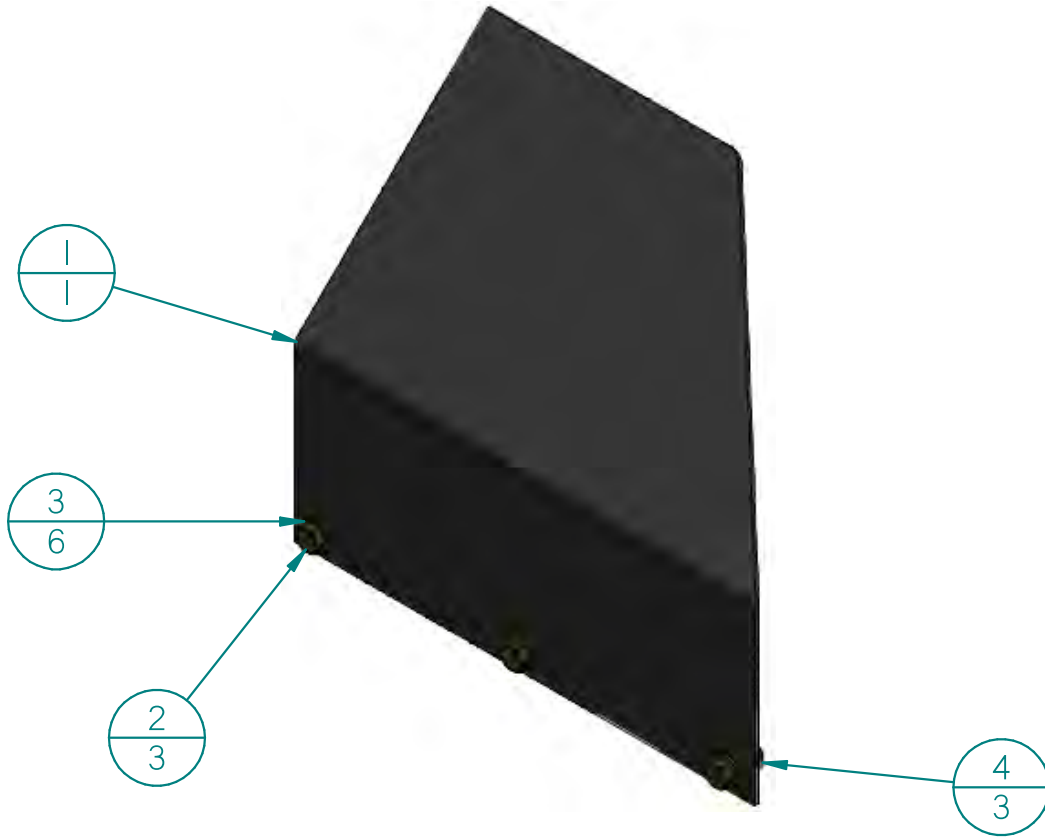

**PRO-MP, MP X, MP XL PINNED WEDGE LIFT**

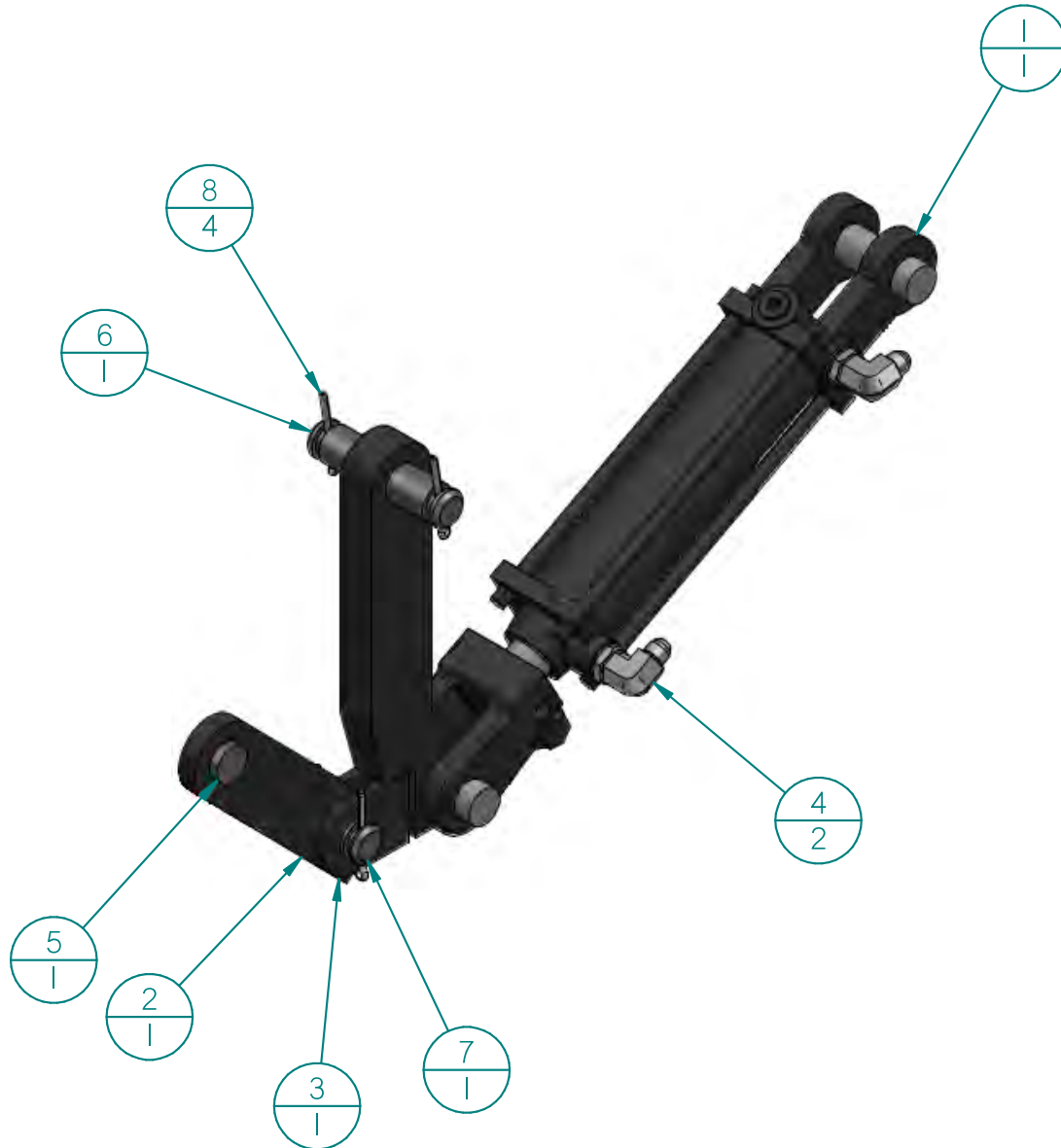

Item No	Part No	Part Name	Qty
1	254-611	2" x 6" Log Lift Cylinder	1
2	9000-0208	Pinned MP Wedge Lift Rocker	1
3	9000-0207	Pinned MP Wedge Lift Center Link	1
4	815-212	#6 JIC M to #8 ORB M 90	2
5	9000-0209	Pin 1"D 1"UL Set Screw	1
6	9001-0007	Pin 1"x3.375"UL	1
7	9001-0150	Pin 1"x1.25"UL	1
8	40000-10002	Zn Cotter Pin 3/16" x 1-1/2" L	4
9	SSSI/4x5	1/4-20 x 1/2 Socket Set Screw	1

## PROCESSOR SAW GUARD

Item No	Part No	Part Name	Qty
1	9000-0226	Pro MP Saw Guard 8-24-23	1
4	9000-0127	Pro Guide Line Bar II-22-21	1
5	40000-00014	Knob Stub Handle	1
6	10000-20006	Encased Neodymium Magnet w/ Threaded Stud, 6mm Thick, 17mm OD, 20mm Long Stud	1
7	10000-20000	Pro Saw Guide Bar (comes with bolt/nut/washer)	1
8	LW3/8	3/8" Spring Washer	1
9	W3/8	W3/8	9
10*	N3/8	N3/8	5
11	HH3/8x1	HH3/8X1	4

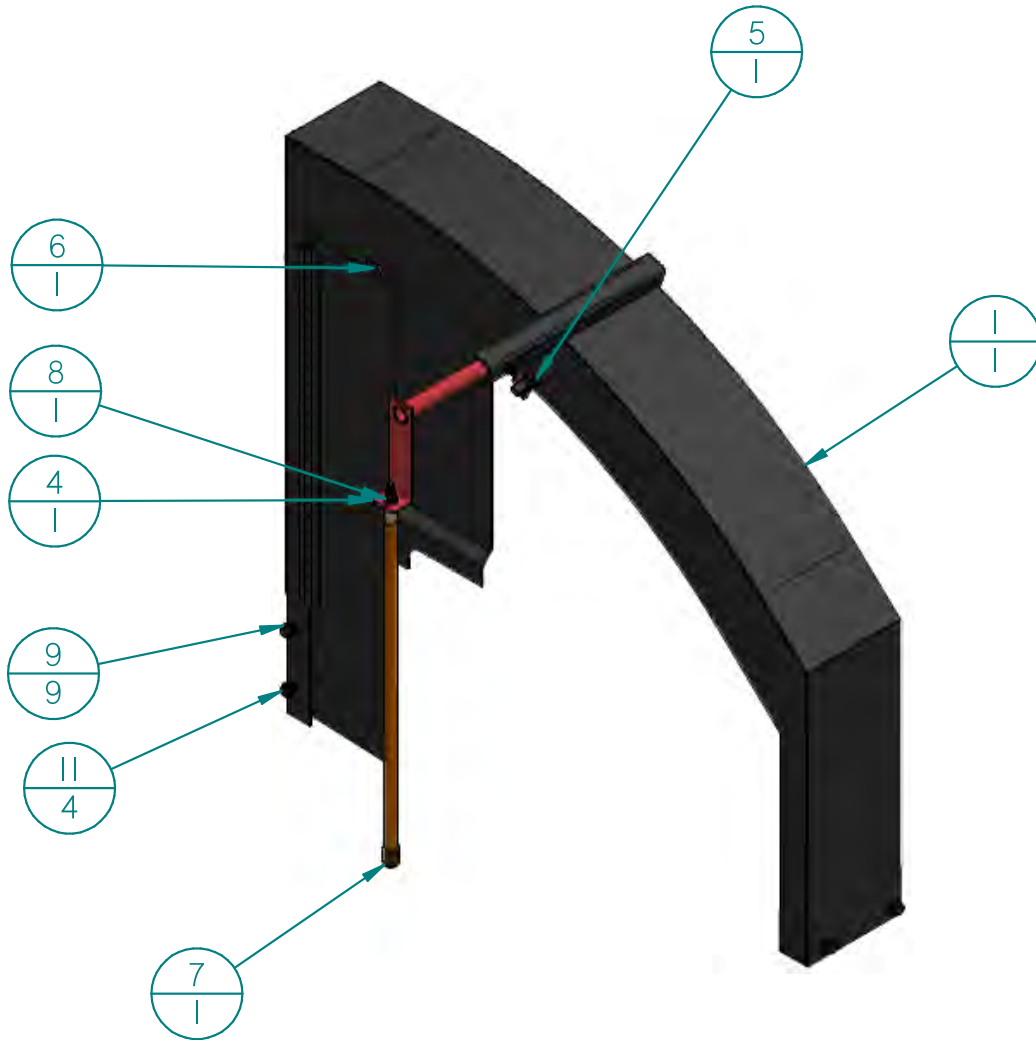

**PROCESSOR DUST CHUTE**

Item No	Part No	Part Name	Qty
1	9000-0227	Pro MP Dust Chute 8-24-23	1
2	NN3/8	NN3/8	4
3	W3/8	W3/8	8
4	HH3/8xL25	HH3/8xL25	4

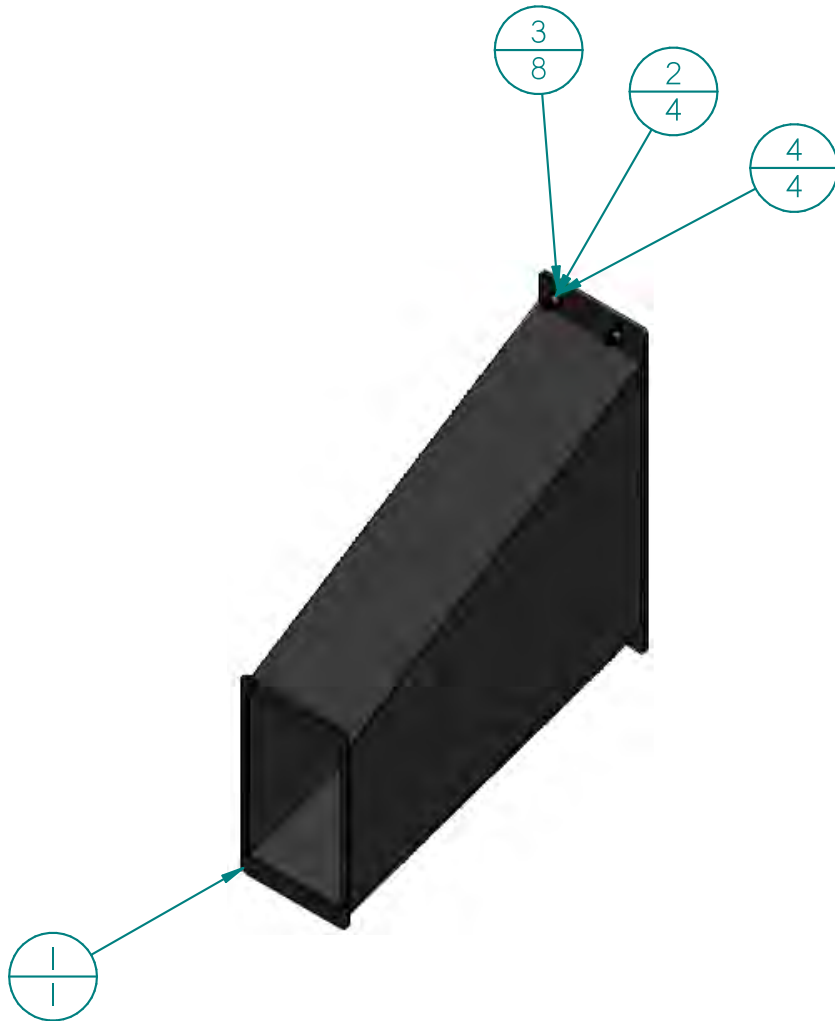

## PROCESSOR SAW BOX

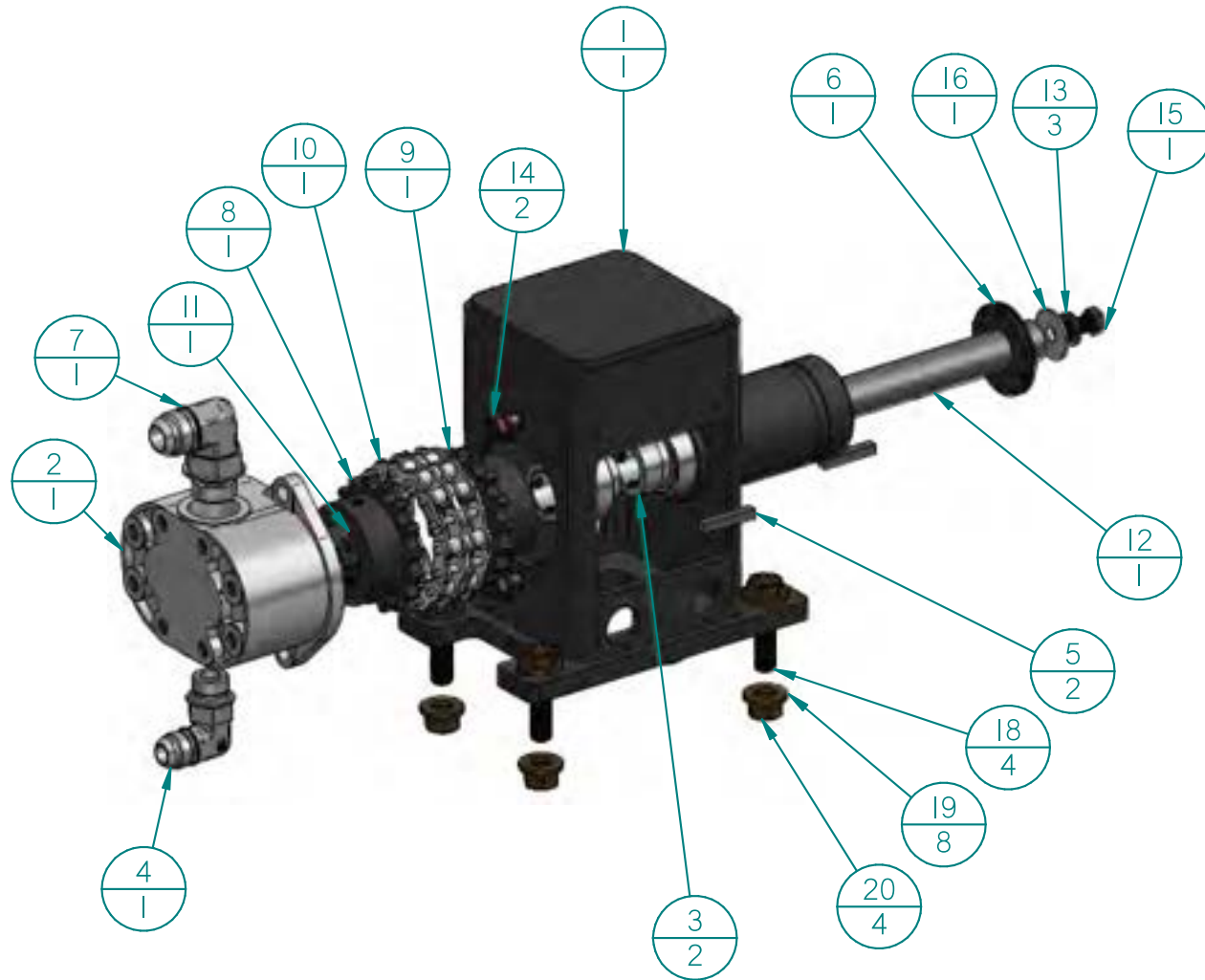

Item No	Part No	Part Name	Qty
1	9000-0256	Saw Box II-28-23	1
2	50000-20012	Danfoss Saw Motor	1
3	30000-30001	Fasner 1100 K RR Arbor Bearing	2
4	815-233	#10 JIC M to #10 ORB M	1
5	10000-11012	1/4"x1.5" Key	2
6	30000-30015	Chain Saw Drive Sprocket 1"	1
7	815-244	#12 JIC M to #12 ORB M 90	1
8	30000-10005	0,75 Chain Coupler 5016	1
9	30000-10004	1" Chain Coupler 5016	1
10	30000-10003	5016 Double Chain	1
11	40000-10011	3/4" Shaft Collar	1
12	9000-0223	Saw Arbor Shaft ID 7.25L Keyed	1
13	W3/8	W3/8	3
14	HH3/8x1.5	HH3/8x1.5	2
15	HH3/8x1	HH3/8x1	1
16	FW3/8	W3/8, OD L25	1
17	N3/8	N3/8	2
18	HH1/2x2	HH1/2x2	4
19	W1/2	W1/2	8
20	N1/2	N1/2	4



**PROCESSOR SAW ARBOR ARM**

Item No	Part No	Part Name	Qty
1	9000-0156	Arbor Arm 5-9-22	1
2	9000-0021	Pro Saw Backing Plate	1
3	9000-0020	Pro Saw Adjuster	1
4	30000-10013	Pro Saw Bar	1
5	875-100	#4 Hose Barb to #4 ORB M	1
6	9000-0155	Pin .75D 2.0625UL snap ring	1
7	30000-10012	.404 Chain	1
8		.75 Retaining Ring	1
9	N9/16	.5625 Nut	2
10	HH1/4x4C5	.25x20 4 Bolt C5	1
11	N1/4	N1/4	1
12	HH3/8x1	HH3/8x1	1
13	N3/8	N3/8	1
14	Grease Fitting 1/4	1/4 Grease Fitting	1

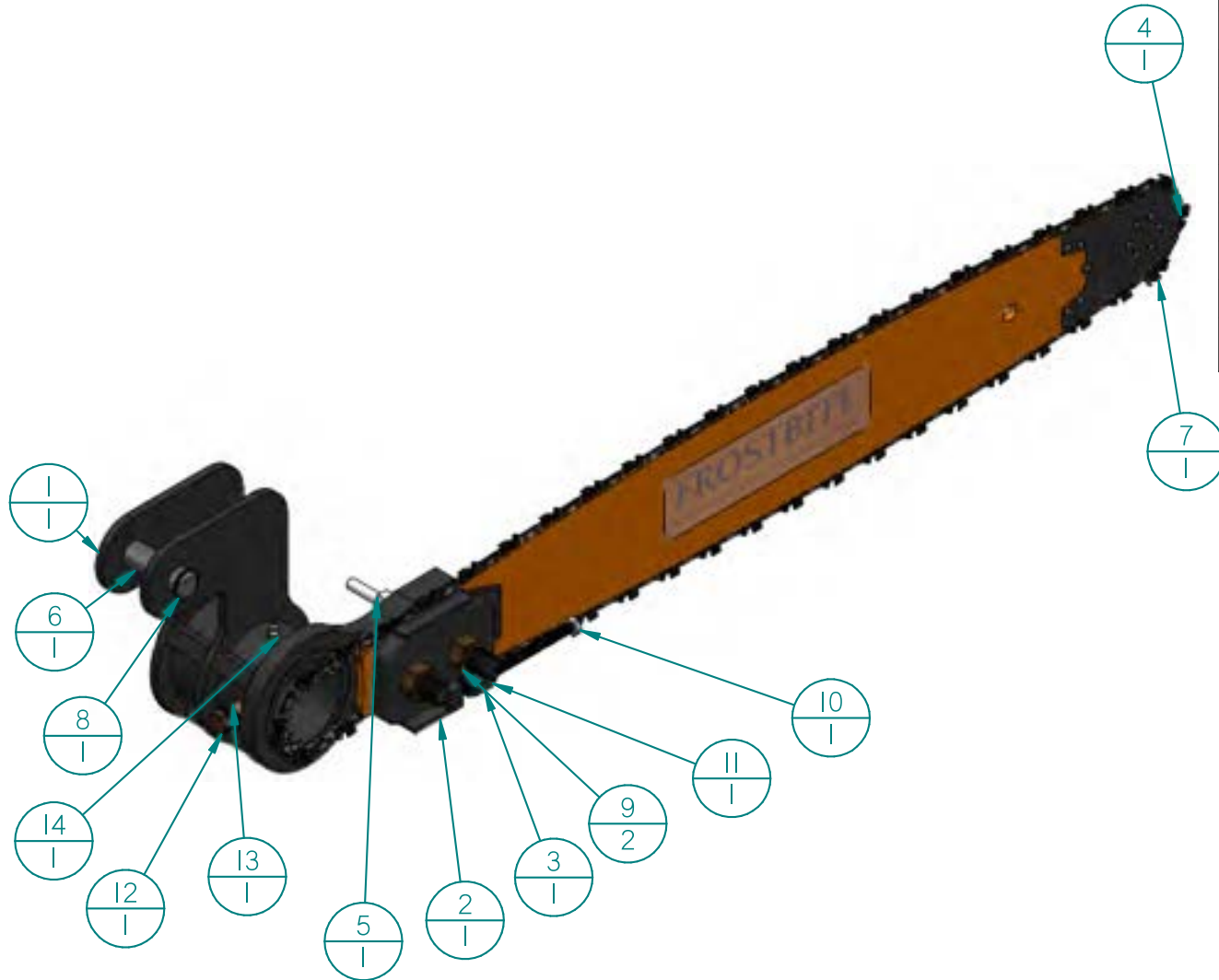

### PROCESSOR SAW CYLINDER CLEVIS

Item No	Part No	Part Name	Qty
1	9000-0170	Pro MP Saw Cyl Clevis 5-23-22	1
2	9000-0169	Pin .75D 2.75UL for Cotter Pins	1
3	40000-10002	Zn Cotter Pin 3/16" x 1-1/2" L	2
4	HH3/8x1.5	HH3/8x1.5	4
5	W3/8	W3/8	8
6	N3/8	N3/8	4

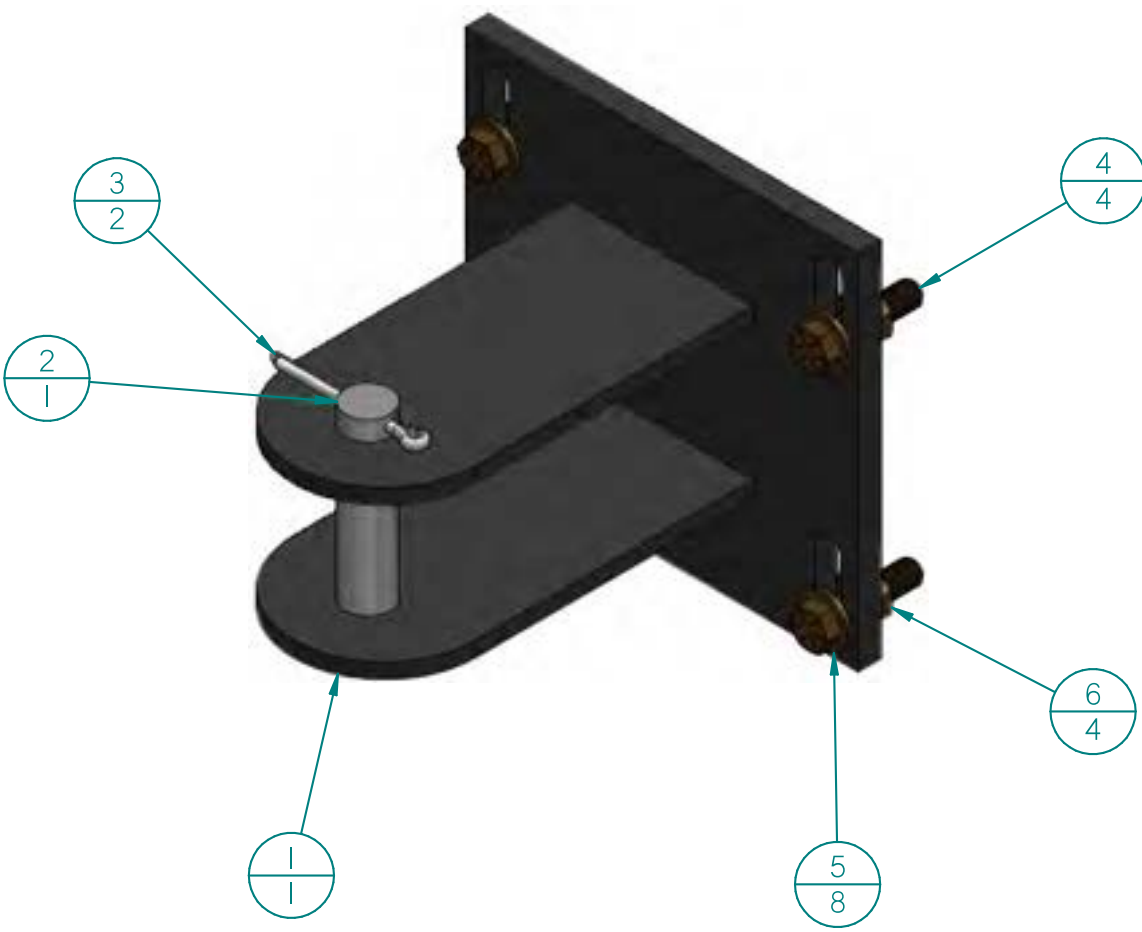

**PRO-MP, MP X, MP XL 70GPM FILTER**

Item No	Part No	Part Name	Qty
1	20000-20018	70 GPM Filter	1
2	20000-20019	70 GPM Filter Head	1
3	873-166	#20 Barb to #20 NPT M	2
4	813-146	#12 JIC M to #20 NPT M	1
5	HH5/16x1	HH5/16x1	2
6	W3/8	W3/8	4

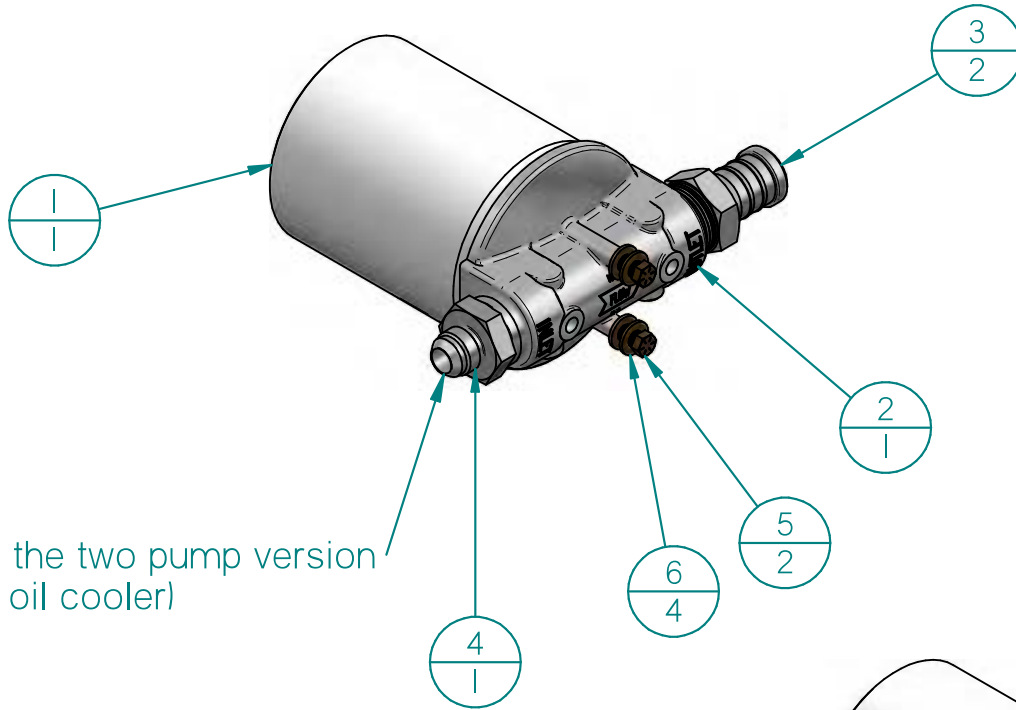

For the two pump version  
(no oil cooler)

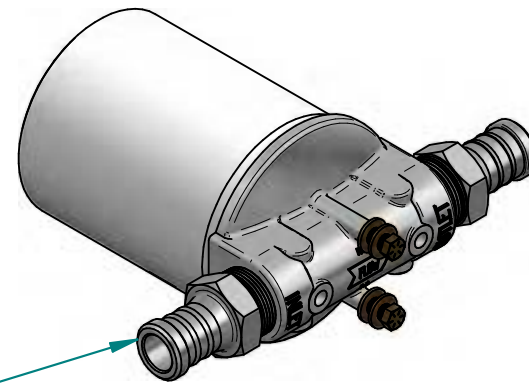

For the three pump version  
(with oil cooler)

## PROCESSOR OIL COOLER

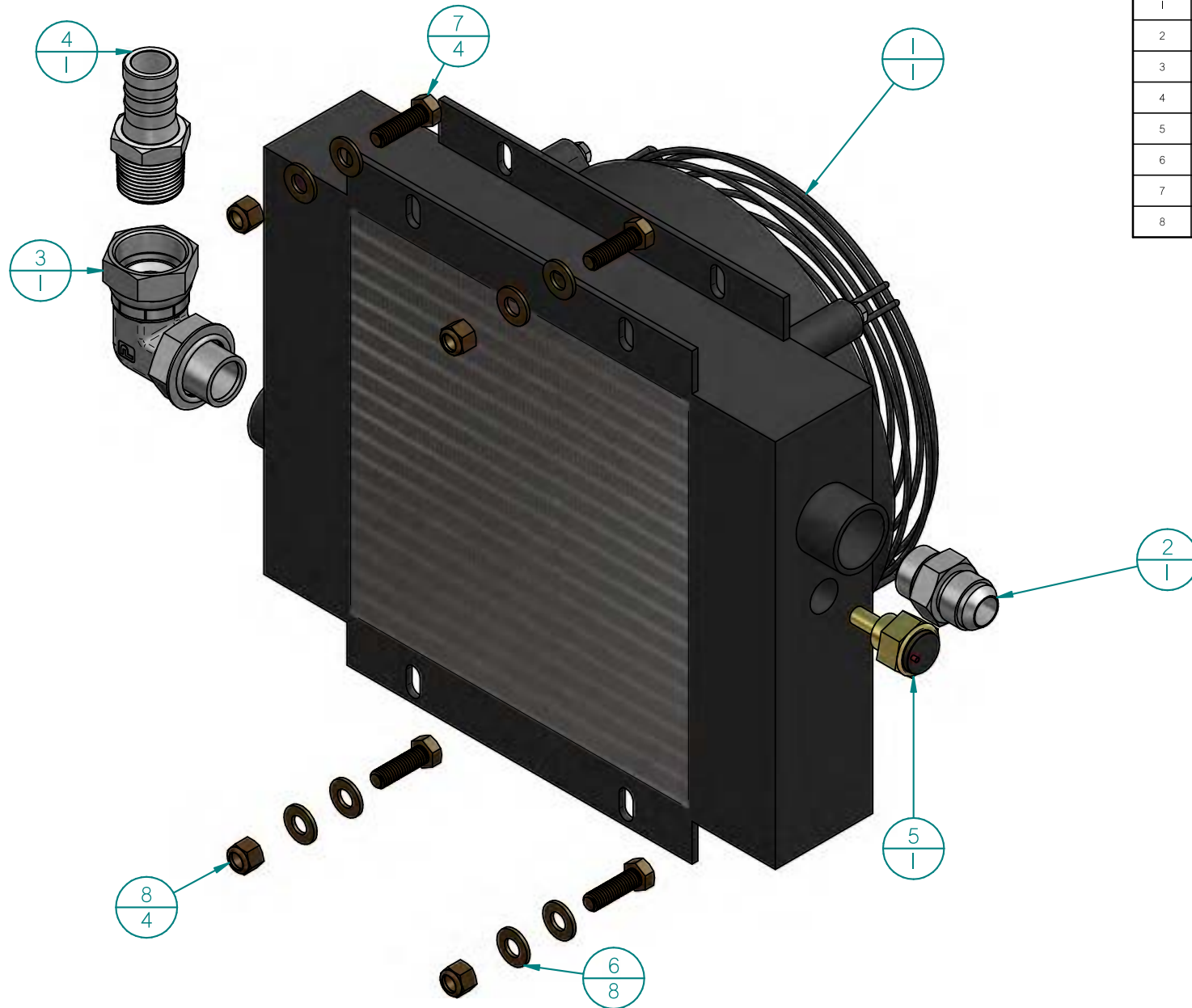

Item No	Part No	Part Name	Qty
1	20000-30002	Oil Cooler	1
2	815-144	#12 JIC M to #12 ORB M	1
3	854-245	#12 ORB M to #16 NPT F	1
4	873-165	#20 Hose Barb to #16 NPT M	1
5	60000-10037	Cooler Temp Switch	1
6	.375 Washer	.375" Washer	8
7	.375x16 I,25 Bolt	3/8"x16 I,25 Bolt	4
8	.375 Lock Nut	.375 Lock Nut	4

**PRO-MP, MP X, MP XL TABLE GRATE**

Item No	Part No	Part Name	Qty
1	9001-0063	Beta Table Grate	1
2	HHI/2x2	HHI/2X2	5
3	WI/2	WI/2	10
4	NNI/2	NNI/2	5

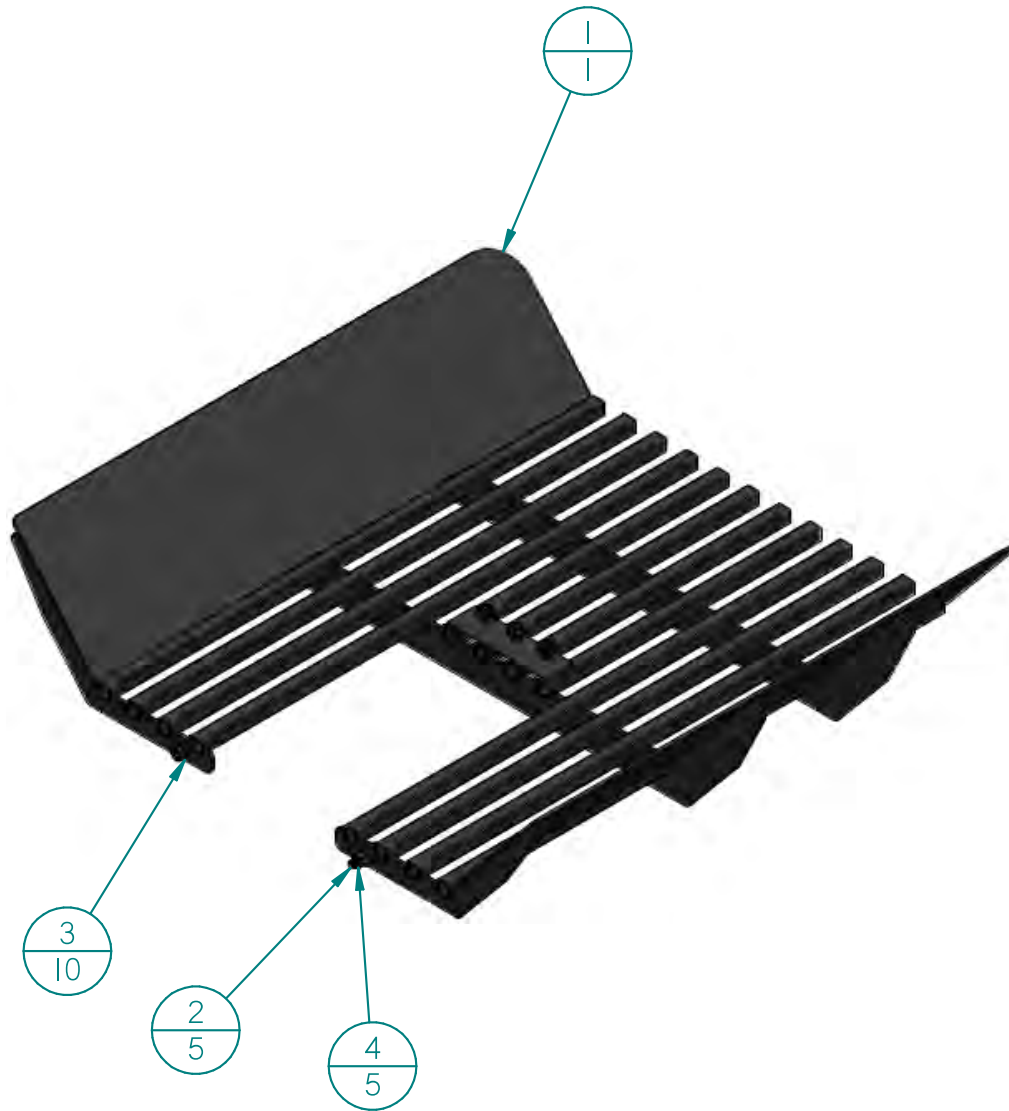

## PRO-MP, MP X, MP XL TABLE GRATE FOR INTEGRATED CONVEYOR

Item No	Part No	Part Name	Qty
1	9000-0272	Table Grate Pro MP 3-6-24	1
2	30000-30002	2 Bolt 1-1/2 Flange Bearing	2
3	CB5/8X2.5	.625x11 2.5 Carriage Bolt	4
4	W5/8	.625 Washer	4
5	N5/8	.625 Nut	4
6	HH1/2x2	.5x13 2 Bolt	5
7	W1/2	.5 Washer	10
8	NN1/2	.5 Lock Nut	5

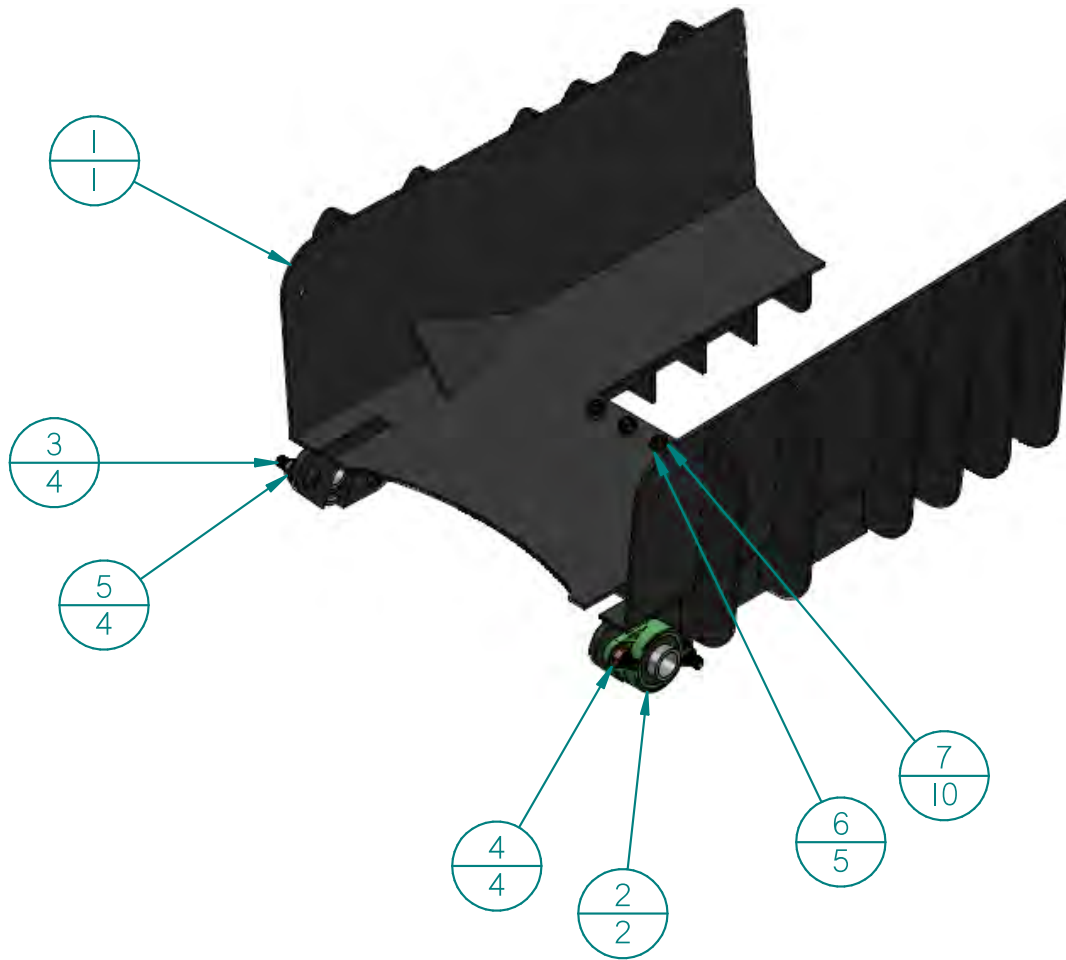

**PRO-MP, MP X, MP XL CONVEYOR LIFT**

Item No	Part No	Part Name	Qty
1	9000-0265	Pro MP Integrated Conveyor Rocker 1-3-24	2
2	9000-0266	Pro MP Integrated Conveyor Link 1-3-24	2
3	901-031	4x6x3 Pro MP Conveyor Lift Cylinder 3-21-24	1
4	9001-0007	Pin 1"x3.375"UL	2
5	815-212	#6 JIC M to #8 ORB M 90	2
6	40000-10002	Zn Cotter Pin 3/16" x 1-1/2" L	8



## PRO-MP, MP X, MP XL CONVEYOR WOLVERINE VALVE

Item No	Part No	Part Name	Qty
1	50000-10004	MB 2 Spool Valve	1
2	815-212	#6 JIC M to #8 ORB M 90	2
3	815-112	#6 JIC M to #8 ORB M	2
4	903-000	3 Position Detent	1
5	W5/16	W5/16	6
6	N5/16	N5/16	3
7	HH5/16x2,5	HH5/16X2,5	3

Note: This is only used if the build has an integrated conveyor

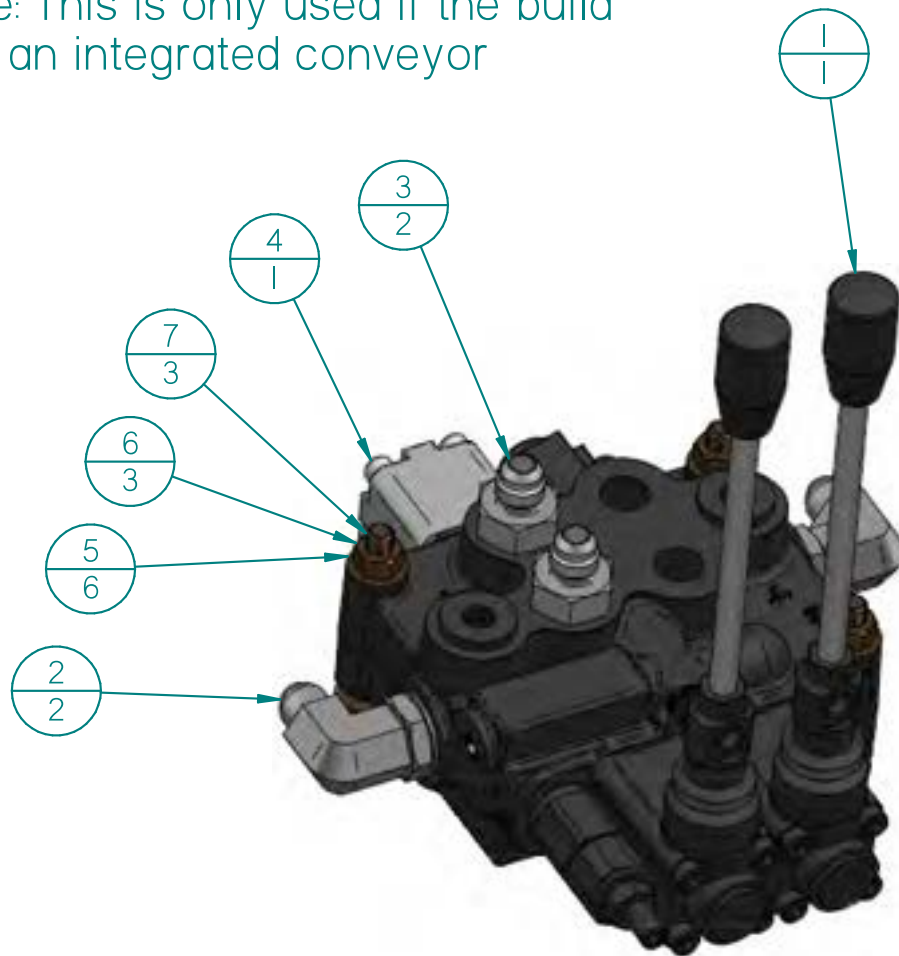



**PRO-MP, MP X, MP XL INTEGRATED CONVEYOR FRAME**

Item No	Part No	Part Name	Qty
1	9000-0261	Pro MP Integrated Conveyor I-3-24	1
2	9002-0036	8in 3/4-10 threaded rod	4
3	40000-10017	I-1/2" Double Split Shaft Collar	4
4	N3/4	.75 Nut	8

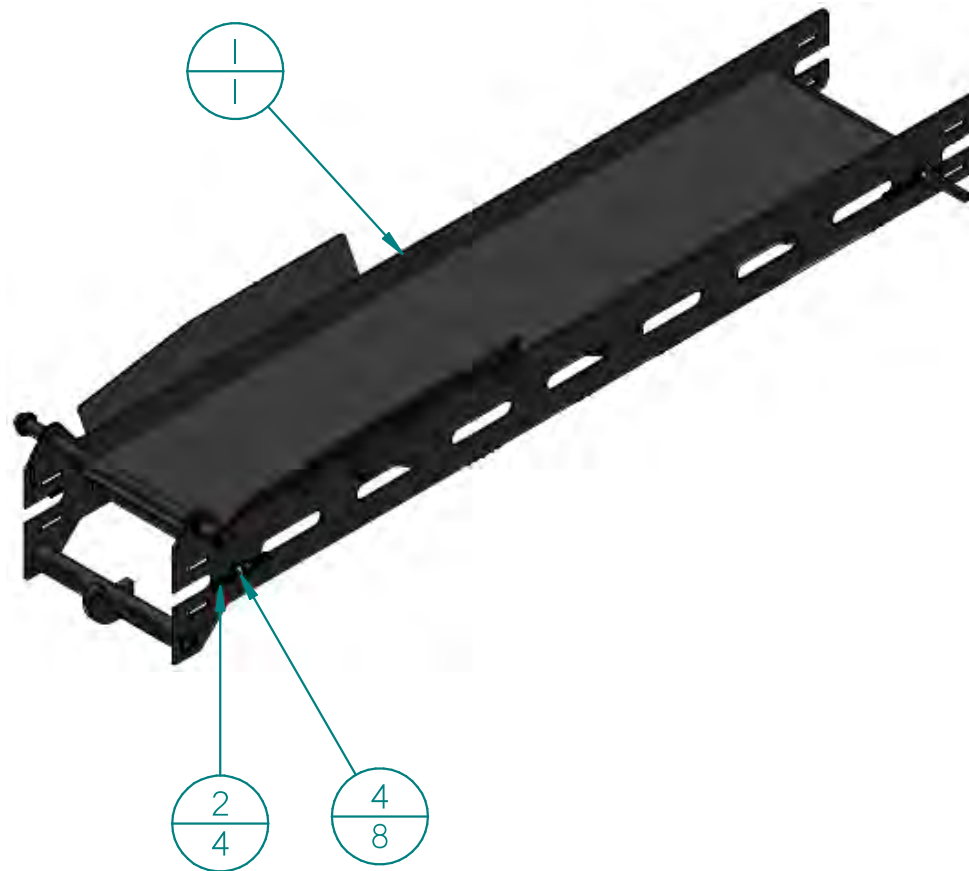

### CONVEYOR IDLER ROLLER

Item No	Part No	Part Name	Qty
1	9002-0035	conveyor bearing plate	2
2	30000-30002	2 Bolt 1-1/2 Flange Bearing	2
3	9002-0018	Conveyor Idle Roller 1,5	1
4	CB5/8X2.5	.625x11 2.5 Carriage Bolt	4
5	N5/8	.625 Nut	4

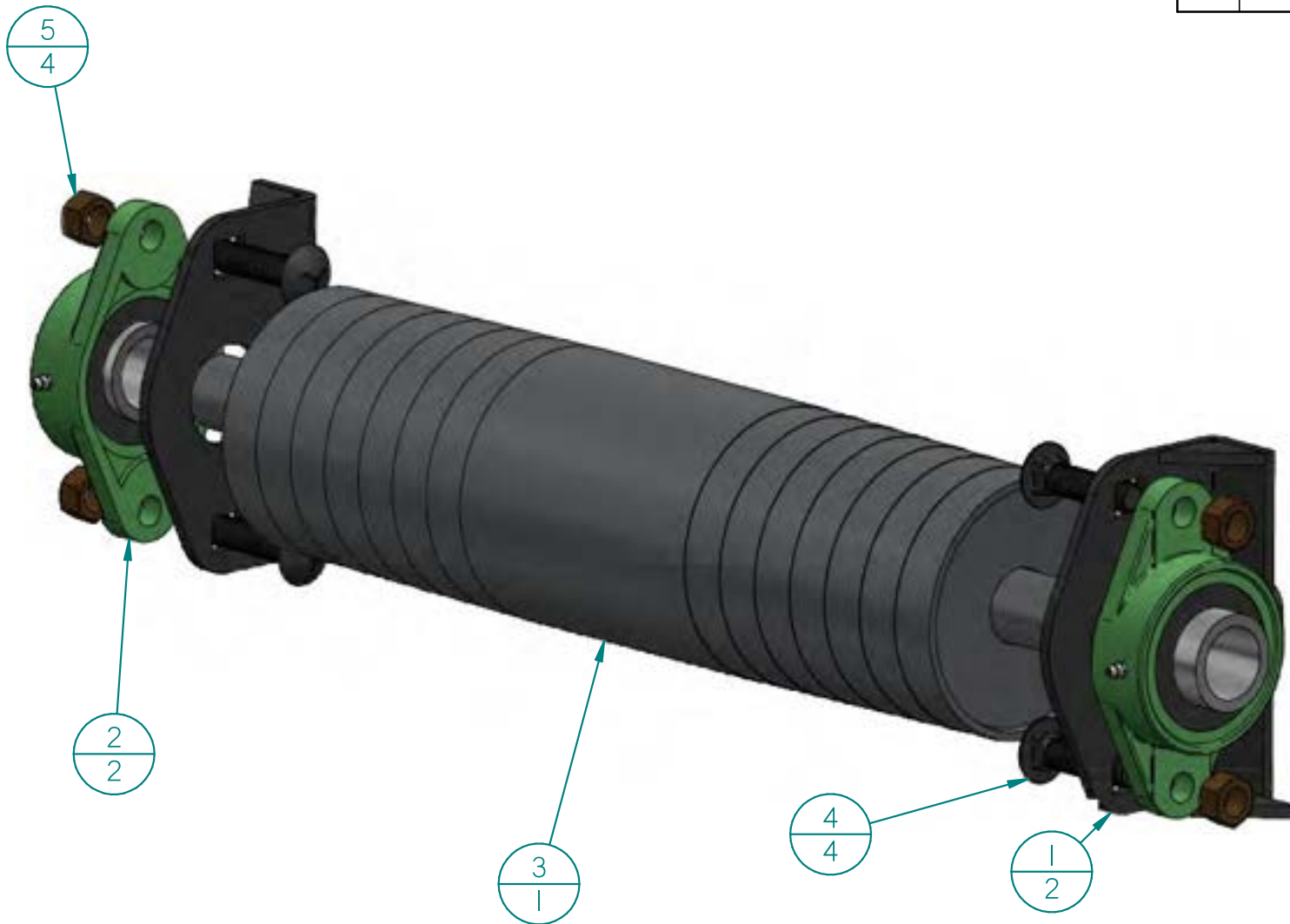

**CONVEYOR DRIVE ROLLER**

Item No	Part No	Part Name	Qty
1	9002-0035	conveyor bearing plate	2
2	30000-30002	2 Bolt 1-1/2 Flange Bearing	2
3	9002-0017	Conveyor Drive Roller 1,5	1
4	30000-20009	Rigid Shaft Coup w/ Keyway I'D	1
5	50000-20011	Anfield Hydraulic Motor 125 2 bolt	1
6	9002-0016	Conveyor Motor Plate Short	1
7	10000-11012	1/4"x1,5" Key	1
8	815-113	#6 JIC M to #10 ORB M	2
9	CB5/8X2,5	CB5/8X2,5	4
10	N5/8	N5/8	4
11	CB1/2X2,5	CB1/2X2,5	2
12	N1/2	N1/2	2

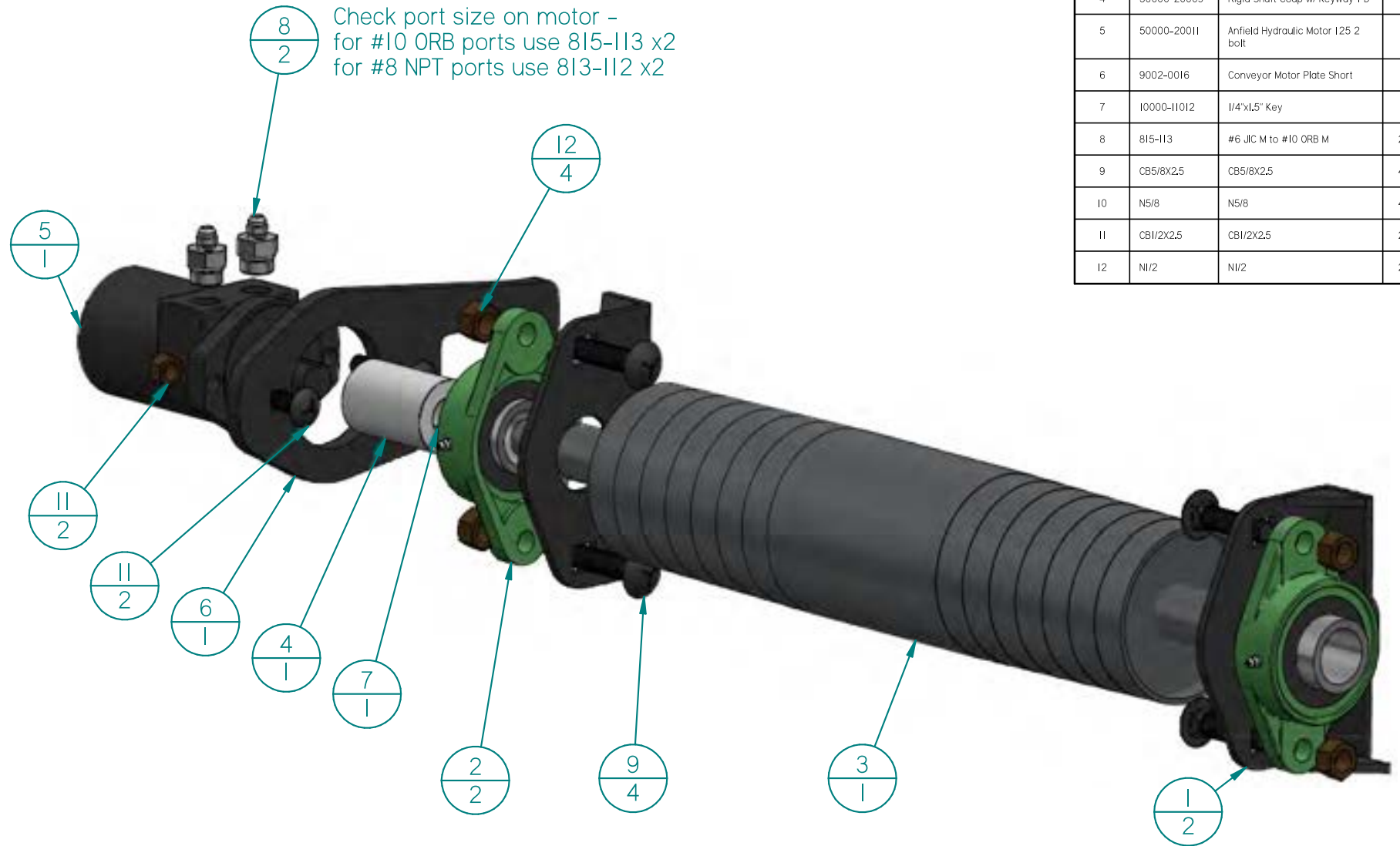

### PRO-MP, MP X, MP XL FLOW DIVIDER

Note: this is only used if the build has a 5.8gpm pump and integrated conveyor

Item No	Part No	Part Name	Qty
1	50000-10015	RD 575	1
2	813-114	#6 JIC to #12 NPT M	3
3	W1/4	W1/4	4
4	HH1/4X2.5	.25x20 2.5 Bolt	2
5	N1/4	N1/4	2

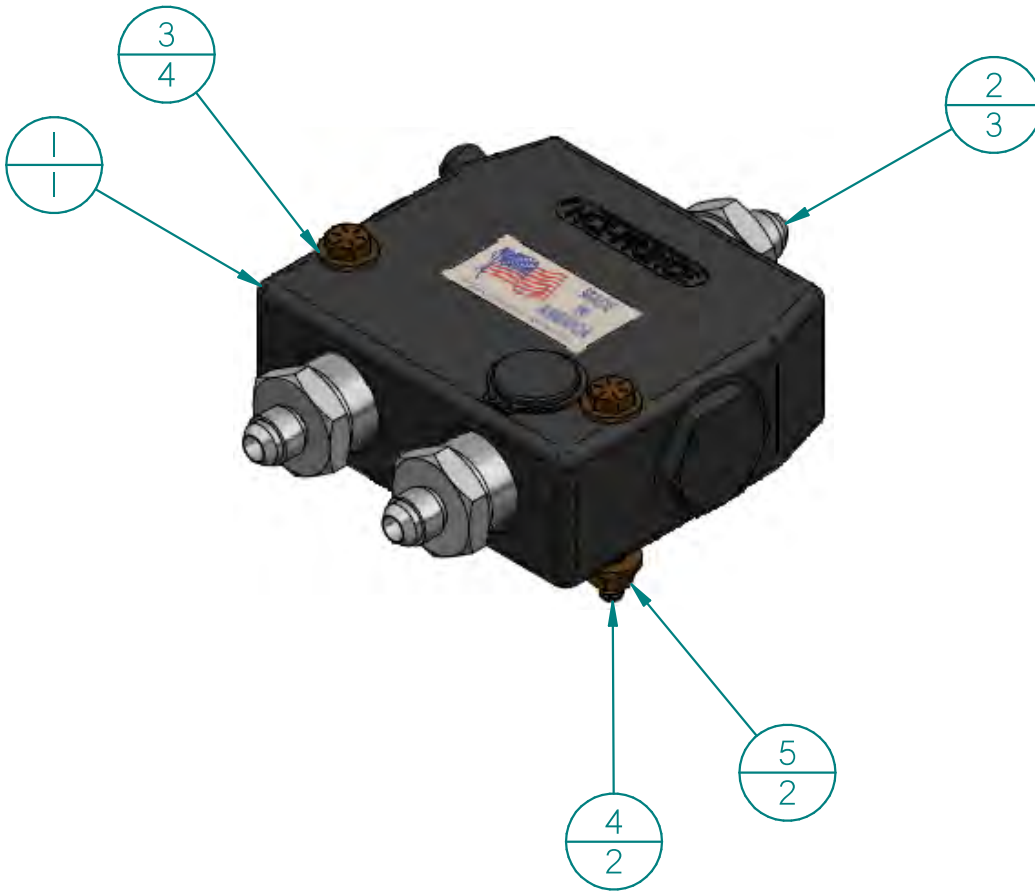

# Hydraulic Schematics

## PRO-HD, HD X, HD XL HOSE ROUTING

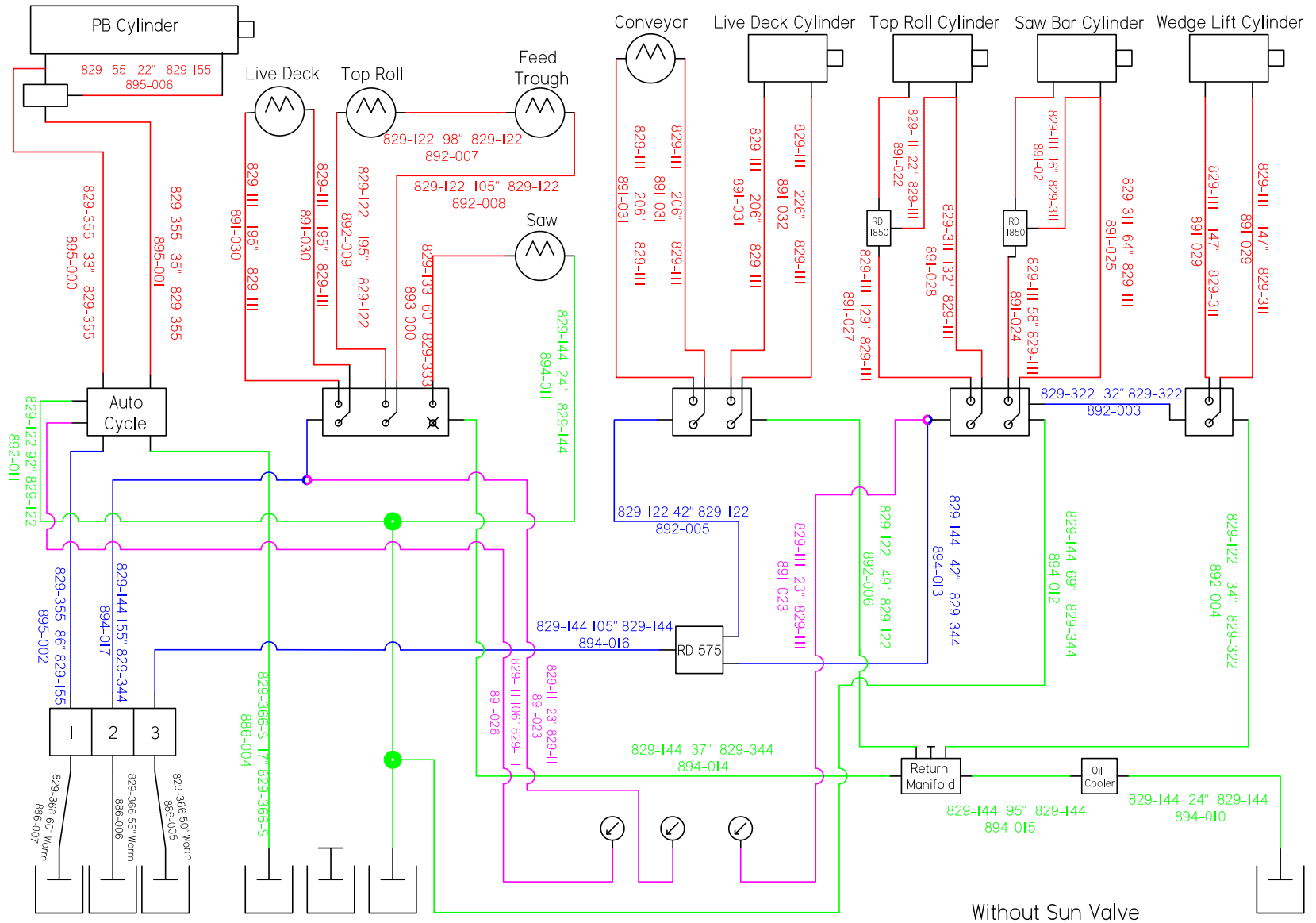

Pro HD						
	Hose Name	Length	Fitting 1	Fitting 2		Part No
Top Roll Cyl. and Clamp	#6 Pressure	22	829-111	829-111	TR Cyl Rod End to RD1850	891-022
	#6 Pressure	129	829-111	829-111	2 Spool to RD 1850	891-027
	#6 Pressure	132	829-111	829-311	TR Cyl Rod End 2 Spool Valve	891-028

Pump	#12 Pressure	105	829-144	829-144	3 Stage to RD 585	894-016
	#12 Pressure	155	829-144	829-344	2 Stage to 3 Spool Valve	894-017
	#12 Pressure	160	829-144	829-344	1 Stage to Auto Cycle Valve	894-025
	#20 Return	50	829-366-S	WC20	Tank to 3 Stage	886-005
	#20 Return	55	829-366-S	WC20	Tank to 2 Stage	886-006
	#20 Return	60	829-366-S	WC20	Tank to 1 Stage	886-007

Live deck motor	#6 Pressure	195	829-111	829-111	3 Spool to LD Motor	891-030
	#6 Pressure	195	829-111	829-111	3 Spool to LD Motor	891-030

FT/ TR Motor	#8 Pressure	98	829-122	829-122	FT Motor to TR Motor	892-007
	#8 Pressure	105	829-122	829-122	3 Spool Valve to TR Motor	892-008
	#8 Pressure	195	829-122	829-122	FT Motor to 3 Spool	892-009

Live deck Cyl.	#6 Pressure	206	829-111	829-111	LD Cyl Solid End to MB 2 Spool	891-031
	#6 Pressure	226	829-111	829-111	LD Cyl Rod End to MB 2 Spool	891-032

Conveyor Optional	#6 Pressure	206	829-111	829-111	Conv Motor to MB 2 Spool	891-031
	#6 Pressure	206	829-111	829-111	Conv Motor to MB 2 Spool	891-031

Return Manifold & Oil Cooler	#8 Pressure	34	829-122	829-322	1 Spool to Manifold	892-004
	#8 Pressure	49	829-122	829-122	MB 2 Spool to Manifold	892-006
	#12 Pressure	24	829-144	829-144	Oil Cooler to Tank	894-010
	#12 Pressure	49	829-144	829-344	3 Spool to Manifold	894-014
	#12 Pressure	95	829-144	829-144	Manifold to Oil Cooler	894-015

WL valve	#8 Pressure	32	829-322	829-322	2 Spool Power Beyond to 1 Spool	892-003
----------	-------------	----	---------	---------	---------------------------------	---------

Saw motor	#10 Pressure	60	829-133	829-333	3 Spool Valve to Saw Motor	893-000
	#12 Pressure	24	829-144	829-144	Saw Motor to Tank	894-011

RD 575	#8 Pressure	42	829-122	829-122	RD 575 to MB 2 Spool	892-005
	#12 Pressure	42	829-144	829-344	RD 575 to 2 Spool	894-013

2 Spool Return	#12 Pressure	69	829-144	829-344	2 Spool to Tank	894-012
----------------	--------------	----	---------	---------	-----------------	---------

	Stight					
	90					

Pressure gauge	#6 Pressure	23	829-111	829-111	2 Spool to Gauge	891-023
	#6 Pressure	23	829-111	829-111	3 Spool to Gauge	891-023
	#6 Pressure	23	829-111	829-311	Auto Cycle to Gauge	891-036

Saw Cyl.	#6 Pressure	16	829-111	829-311	Saw Cyl Rod End to RD1850	891-021
	#6 Pressure	58	829-111	829-111	2 Spool to RD1850	891-024
	#6 Pressure	64	829-111	829-311	2 Spool to Saw Cyl Rod End	891-025

Wedge Lift Cyl.	#6 Pressure	147	829-111	829-311	1 Spool to WL Cylinder	891-029
	#6 Pressure	147	829-111	829-311	1 Spool to WL Cylinder	891-029

Auto Cycle Valve	#12 Pressure	22	829-144	829-144	PB Rod End to Solid End Tee	894-029
	#12 Pressure	44	829-144	829-344	Autocycle Valve Left Front to Tee	894-022
	#12 Pressure	44	829-144	829-344	Tee to Solid End Manifold	894-022
	#12 Pressure	49	829-144	829-344	Autocycle Valve Right Back to Tee	894-014
	#12 Pressure	77	829-144	829-144	Autocycle Valve Left Balc to Solid End Tee	894-023
	#12 Pressure	98	829-144	829-144	Autocycle Valve to Tank	894-024

	Stight					
	90					

Pro HD X/XL						
	Hose Name	Length	Fitting 1	Fitting 2		Part No
Top Roll Cyl. and Clamp	#6 Pressure	22	829-111	829-111	TR Cyl Rod End to RD1850	891-022
	#6 Pressure	129	829-111	829-111	2 Spool to RD 1850	891-027
	#6 Pressure	132	829-111	829-311	TR Cyl Rod End 2 Spool Valve	891-028

Pump	#12 Pressure	105	829-144	829-144	3 Stage to RD 585	894-016
	#12 Pressure	155	829-144	829-344	2 Stage to 3 Spool Valve	894-017
	#16 Pressure	86	829-155	829-355	1 Stage to Auto Cycle	895-002
	#20 Return	50	829-366-S	WC20	Tank to 3 Stage	886-005
	#20 Return	55	829-366-S	WC20	Tank to 2 Stage	886-006
	#20 Return	60	829-366-S	WC20	Tank to 1 Stage	886-007

Live deck motor	#6 Pressure	195	829-111	829-111	3 Spool to LD Motor	891-030
	#6 Pressure	195	829-111	829-111	3 Spool to LD Motor	891-030

FT/ TR Motor	#8 Pressure	98	829-122	829-122	FT Motor to TR Motor	892-007
	#8 Pressure	105	829-122	829-122	3 Spool Valve to TR Motor	892-008
	#8 Pressure	195	829-122	829-122	FT Motor to 3 Spool	892-009

Live deck Cyl.	#6 Pressure	206	829-111	829-111	LD Cyl Solid End to MB 2 Spool	891-031
	#6 Pressure	226	829-111	829-111	LD Cyl Rod End to MB 2 Spool	891-032

Conveyor Optional	#6 Pressure	206	829-111	829-111	Conv Motor to MB 2 Spool	891-031
	#6 Pressure	206	829-111	829-111	Conv Motor to MB 2 Spool	891-031

Return Manifold & Oil Cooler	#8 Pressure	34	829-122	829-322	1 Spool to Manifold	892-004
	#8 Pressure	49	829-122	829-122	MB 2 Spool to Manifold	892-006
	#12 Pressure	24	829-144	829-144	Oil Cooler to Tank	894-010
	#12 Pressure	37	829-144	829-344	3 Spool to Manifold	894-014
	#12 Pressure	95	829-144	829-144	Manifold to Oil Cooler	894-015

WL valve	#8 Pressure	32	829-322	829-322	2 Spool Power Beyond to 1 Spool	892-003
----------	-------------	----	---------	---------	---------------------------------	---------

Saw motor	#10 Pressure	60	829-133	829-333	3 Spool Valve to Saw Motor	893-000
	#12 Pressure	24	829-144	829-144	Saw Motor to Tank	894-011

RD 575	#8 Pressure	42	829-122	829-122	RD 575 to MB 2 Spool	892-005
	#12 Pressure	42	829-144	829-344	RD 575 to 2 Spool	894-013

2 Spool Return	#12 Pressure	69	829-144	829-344	2 Spool to Tank	894-012
----------------	--------------	----	---------	---------	-----------------	---------

	Stight					
	90					

Pressure gauge	#6 Pressure	23	829-111	829-111	2 Spool to Gauge	891-023
	#6 Pressure	23	829-111	829-111	3 Spool to Gauge	891-023
	#6 Pressure	106	829-111	829-311	Auto Cycle to Gauge	891-026

Saw Cyl.	#6 Pressure	16	829-111	829-311	Saw Cyl Rod End to RD1850	891-021
	#6 Pressure	58	829-111	829-111	2 Spool to RD1850	891-024
	#6 Pressure	64	829-111	829-311	2 Spool to Saw Cyl Rod End	891-025

Wedge Lift Cyl.	#6 Pressure	147	829-111	829-311	1 Spool to WL Cylinder	891-029
	#6 Pressure	147	829-111	829-311	1 Spool to WL Cylinder	891-029

Auto Cycle	#16 Pressure	22	829-155	829-155	PB Rod to Solid End	895-006
	#16 Pressure	33	829-355	829-355	Auto Cycle to PB Solid End Tee	895-000
	#16 Pressure	35	829-355	829-355	Auto Cycle to PB Solid End Manifold	895-001
	#8 Pressure	98	829-122	829-322	Auto Cycle to Tank	892-011
	#20 Suction	17	829-366-S	829-366-S	Auto Cycle to Tank	886-004

	Stight					
	90					

**PRO-HD, HD X, HD XL  
INTEGRATED CONVEYOR HOSE ROUTING  
(OPTIONAL ADD ON)**

800-033

800-088 #6 Pressure Hose  
829-III 206" 829-3II



800-034

800-088 #6 Pressure Hose  
829-III 206" 829-3II

829-III End May need Quick Disconnect



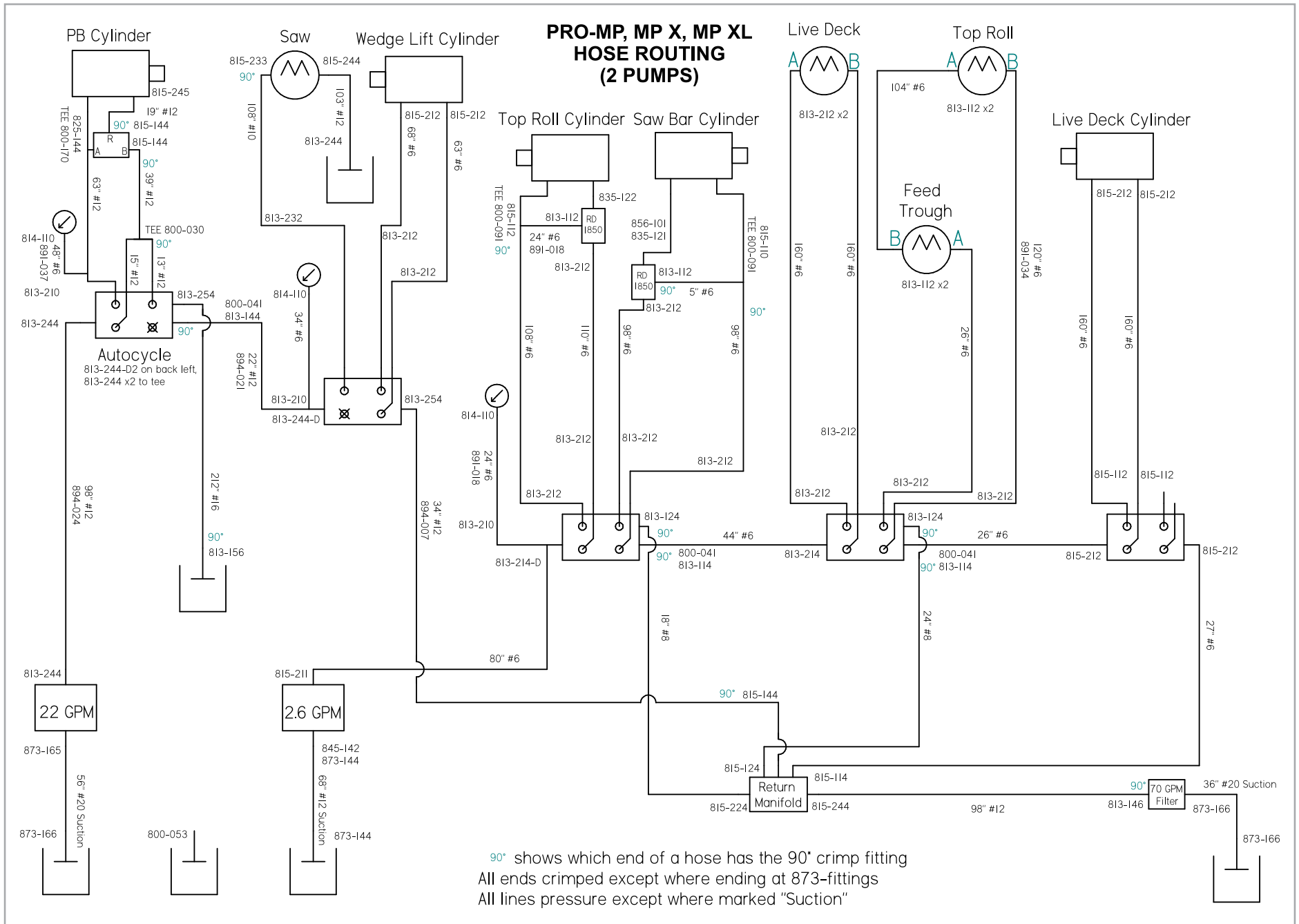

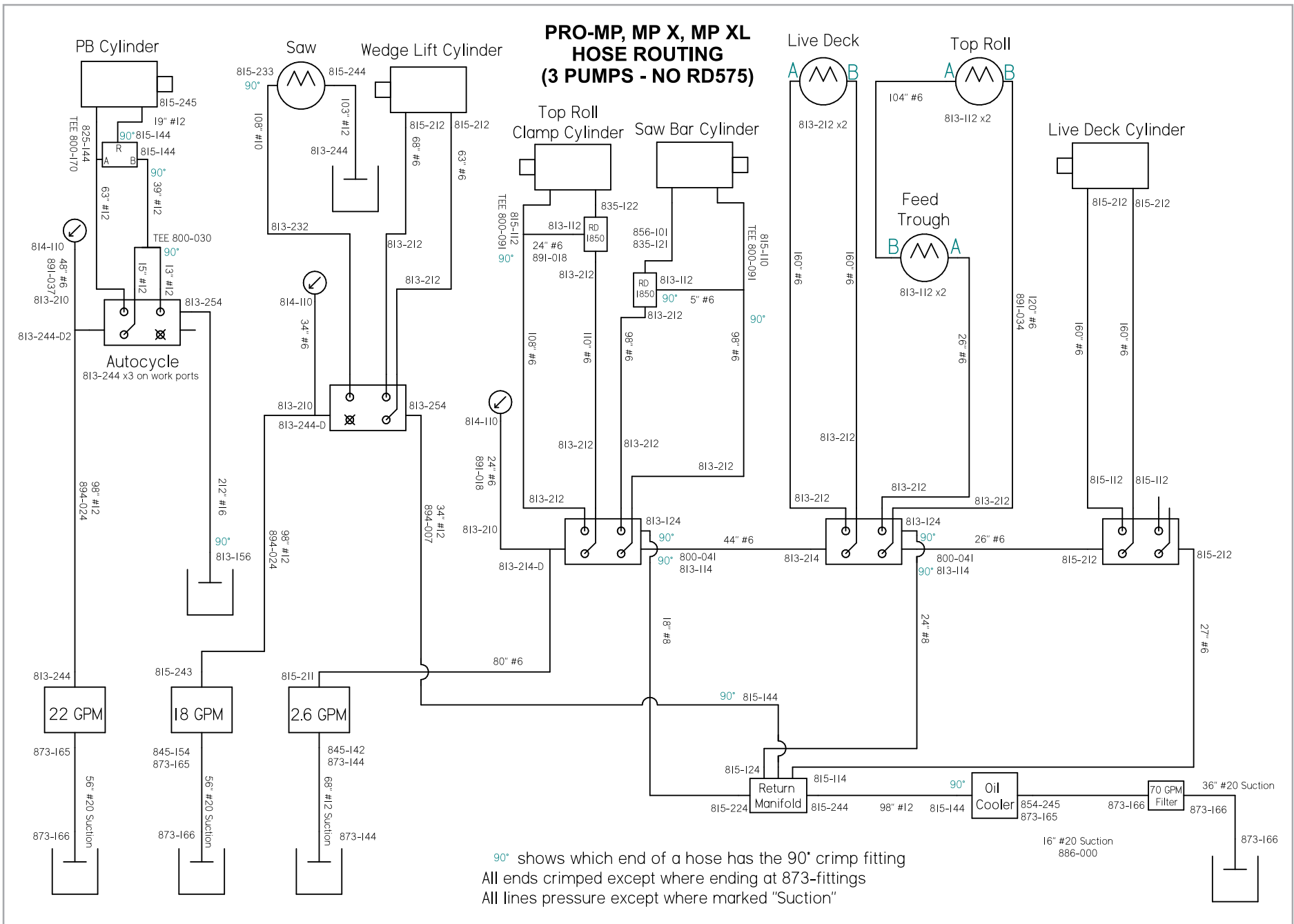



## Limited Warranty

Product Covered	This warranty is for Timberwolf Firewood Processing Equipment branded log splitters, conveyors, wood processors, and their attachments or accessories.
Date Warranty Begins	The warranty begins on the date of sale and is warranted by Timberwolf Firewood Processing Equipment to the original purchaser only.
What We Will Do for You:	We or your authorized dealer will, at our option, repair or replace any part found to be defective in material or workmanship, without charge for parts or labor, to the original purchaser for a period of time of one year. However, charges for pickup, delivery, and service calls are not covered by this warranty. The engine is warranted separately by the engine manufacturer.
What Is Not Covered	This warranty does not apply to parts that have been damaged by accident, alteration, misuse, abuse or improper lubrication.
Limited Commercial Use Warranty	If used for rental purposes, the warranty on this product is limited in duration to 90 days from date of purchase. This warranty does not apply to parts that have been damaged by accident, alteration, misuse, abuse or improper lubrication. The engine for commercial use is warranted separately by the engine manufacturer.
How To Get Service	To obtain service, contact our nearest dealer, or Timberwolf Firewood Processing Equipment at 2235 Clarks Corners Road, Marathon, NY 13803, or call us at 1-800-340-4386. For engines, contact us or our dealers, or consult your Yellow Pages for the name of the service dealer that is authorized by the manufacturer.
Disclaimer of Consequential Damages	Timberwolf Firewood Processing Equipment shall not be liable under any circumstances for any incidental or consequential damages or expenses of any kind, including – but not limited to – the cost of equipment rental, loss of profits, or cost of hiring services to perform tasks normally performed by the equipment.

<p>Limitation of Implied Warranties</p>	<p>Any implied warranties, including without limitation any implied warranty of merchantability or fitness for a particular purpose, shall be limited in duration to a period of one year (90 days if product is purchased for commercial or other non-residential use) from the date of sale.</p> <p>Some states do not allow the exclusion or limitation of incidental or consequential damages, or limitation on how long an implied warranty lasts.</p>
<p>Your Rights Under State Law</p>	<p>This warranty gives you specific legal rights, and you may also have other rights, which vary from state to state.</p>







# OPERATOR'S MANUAL



**TIMBERWOLF**  
FIREWOOD PROCESSING EQUIPMENT

2235 Clarks Corners Road, Marathon, NY 13803 800-340-4386 [www.timberwolfequip.com](http://www.timberwolfequip.com)

©TFP2018/G2W0218/500